

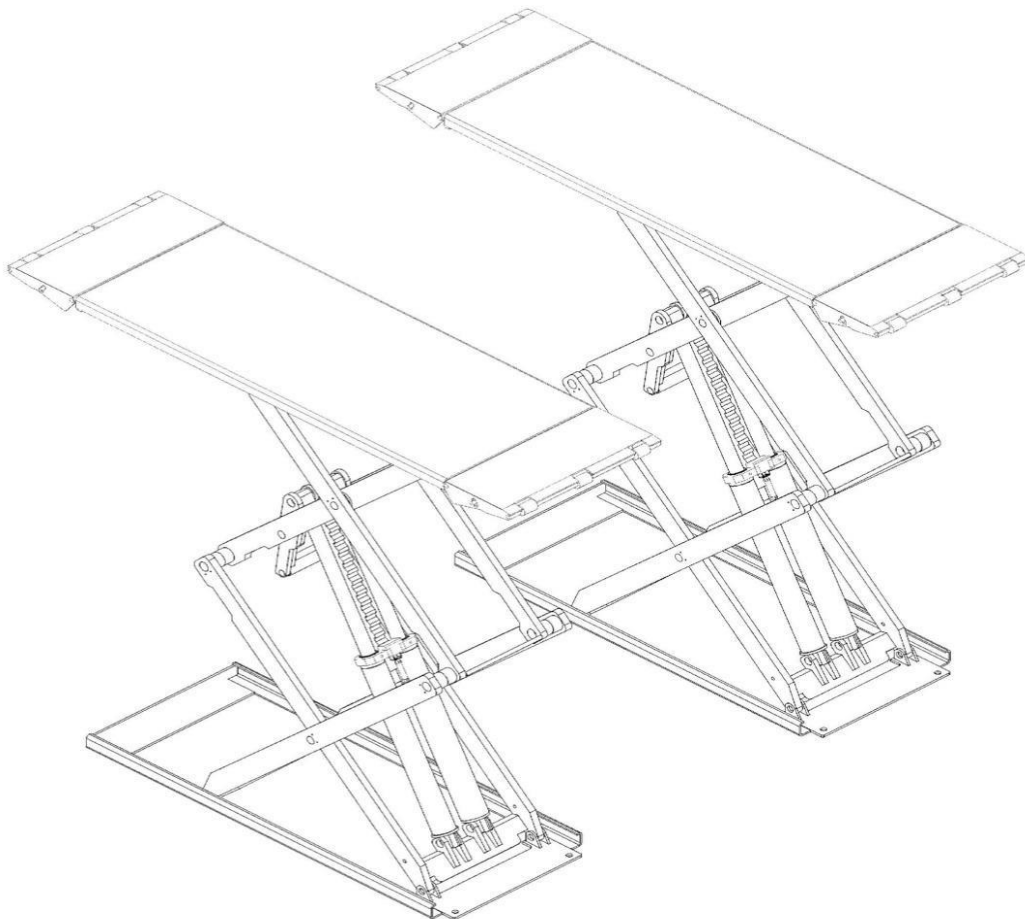

## 6,600lb High Rise Scissor Lift

### LHS7

### User Manual



Serial No. \_\_\_\_\_





# AUTHORIZATION TO MARK

This authorizes the application of the Certification Mark(s) shown below to the models described in the Product(s) Covered section when made in accordance with the conditions set forth in the Certification Agreement and Listing Report. This authorization also applies to multiple listee model(s) identified on the correlation page of the Listing Report.

This document is the property of Intertek Testing Services and is not transferable. The certification mark(s) may be applied only at the location of the Party Authorized To Apply Mark.

<b>Applicant:</b>	YangZhou HuaSheng Motors Manufacturing Co., Ltd	<b>Manufacturer:</b>	YangZhou HuaSheng Motors Manufacturing Co., Ltd
<b>Address:</b>	88# North FeiDa Road, XieJia Town, GaoYou City JiangSu, China	<b>Address:</b>	88# North FeiDa Road, XieJia Town, GaoYou City JiangSu, China
<b>Country:</b>	China	<b>Country:</b>	China
<b>Contact:</b>	Mr. Mao Qun Dai	<b>Contact:</b>	Mr. Mao Qun Dai
<b>Phone:</b>	86-514-84738899	<b>Phone:</b>	86-514-84738899
<b>FAX:</b>	86-514-8473858	<b>FAX:</b>	86-514-8473858
<b>Email:</b>	18952558588@189.com	<b>Email:</b>	18952558588@189.com

**Party Authorized To Apply Mark:** Same as Manufacturer  
**Report Issuing Office:** Intertek Testing Services Shenzhen Ltd. Guangzhou Branch.

**Control Number:** 3191617

**Authorized by:**   
Thomas J. Patterson, Certification Manager



This document supersedes all previous Authorizations to Mark for the noted Report Number.

This Authorization to Mark is for the exclusive use of Intertek's Client and is provided pursuant to the Certification agreement between Intertek and its Client. Intertek's responsibility and liability are limited to the terms and conditions of the agreement. Intertek assumes no liability to any party other than to the Client in accordance with the agreement, for any loss, expense or damage occasioned by the use of this Authorization to Mark. Only the Client is authorized to permit copying or distribution of this Authorization to Mark and then only in its entirety. Use of Intertek's Certification mark is restricted to the conditions laid out in the agreement and in this Authorization to Mark. Any further use of the Intertek name for the sale or advertisement of the tested material, product or service must first be approved in writing by Intertek. Initial Factory Assessments and Follow up Services are for the purpose of assuring appropriate usage of the Certification mark in accordance with the agreement, they are not for the purposes of production quality control and do not relieve the Client of their obligations in this respect.

Intertek Testing Services NA Inc.  
545 East Algonquin Road, Arlington Heights, IL 60005  
Telephone 800-345-3851 or 847-439-5667 Fax 312-283-1672

<b>Standard(s):</b>	Rotating Electrical Machines – General Requirements - UL1004-1, 2nd Ed., Rev. Sep. 27, 2013 Motors and Generators - CSA C22.2 No.100-04 (R2013)
<b>Product:</b>	Hydraulic AC Motor
<b>Models:</b>	YL90GA-2, YL90GB-2

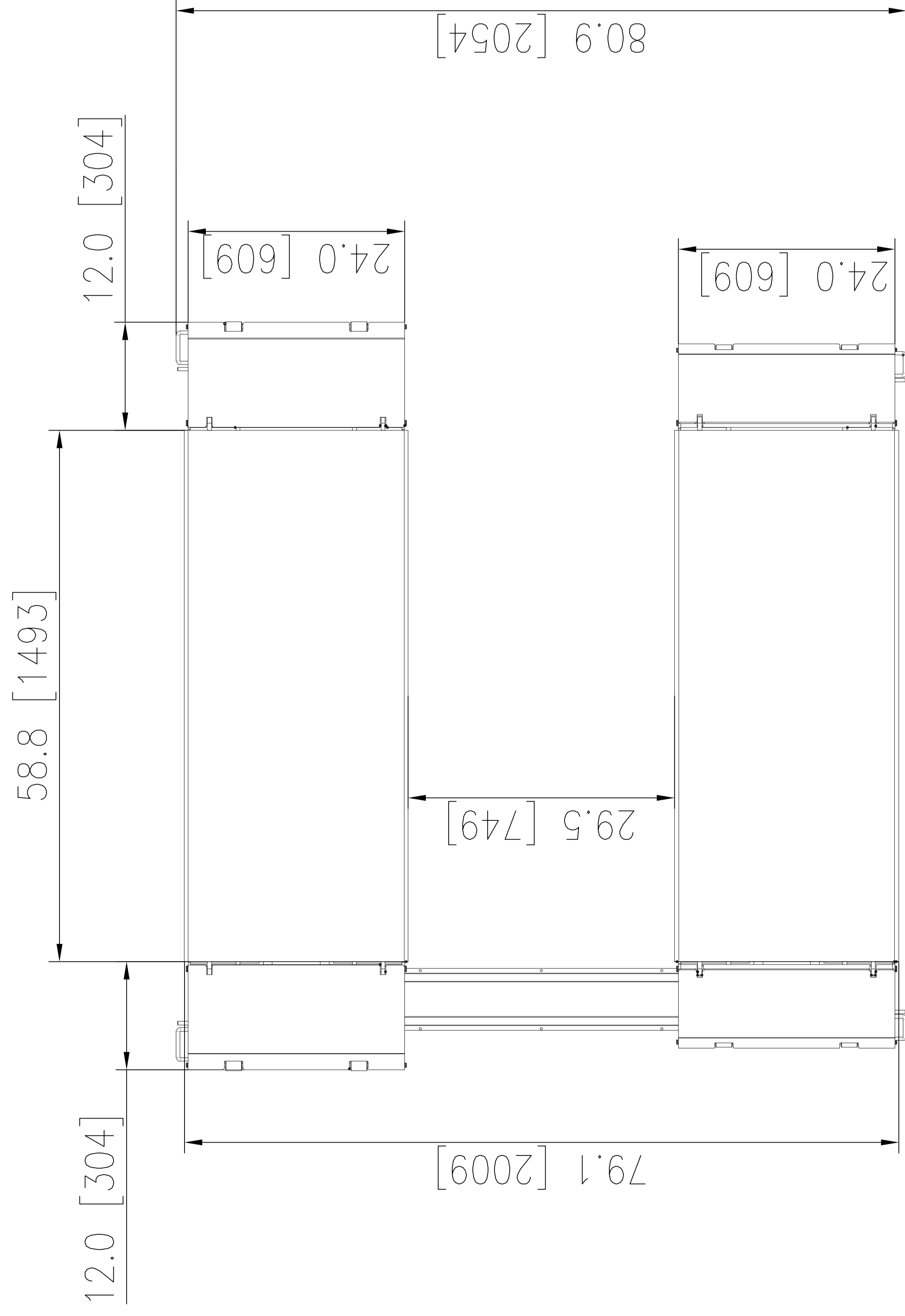
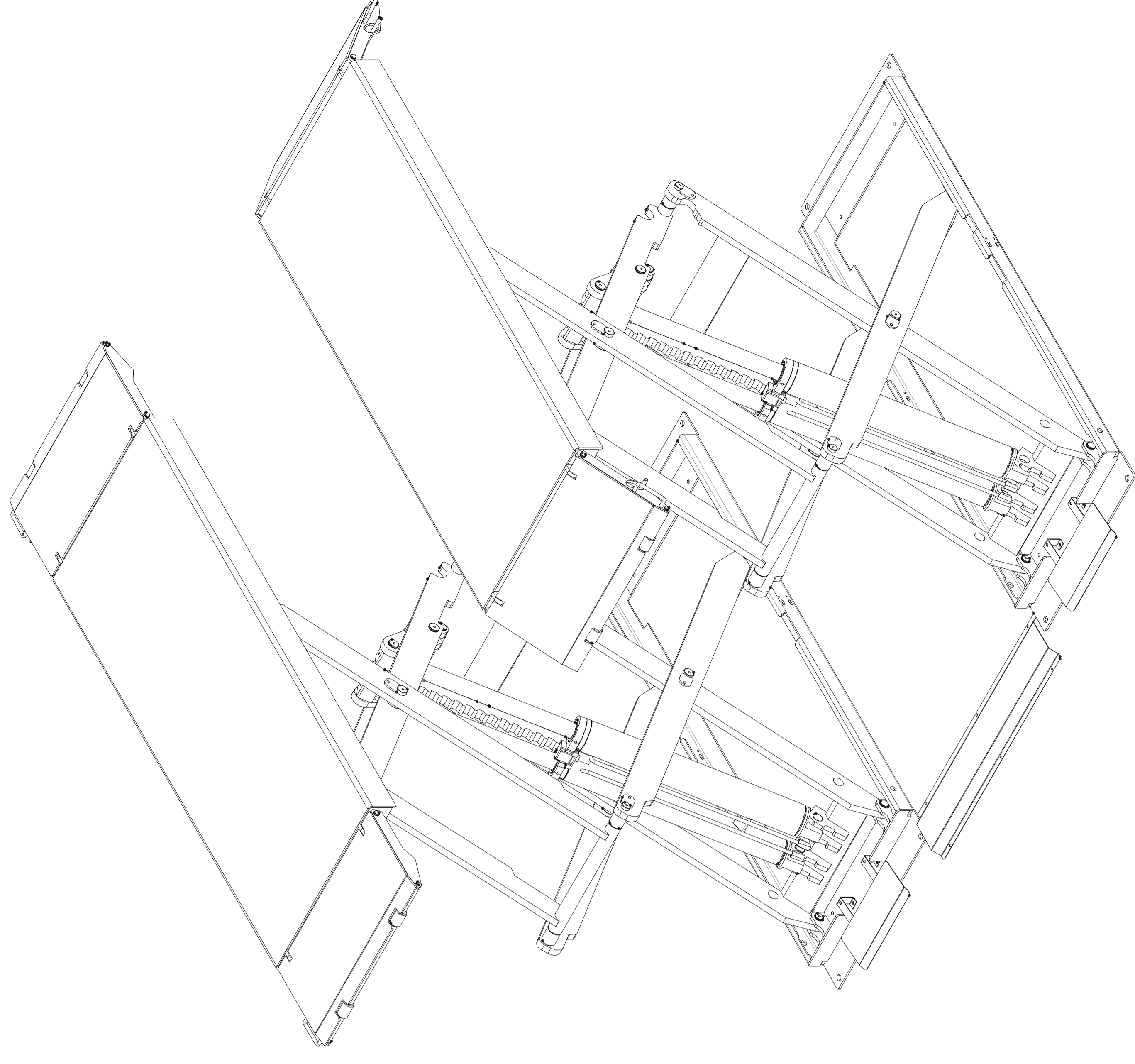
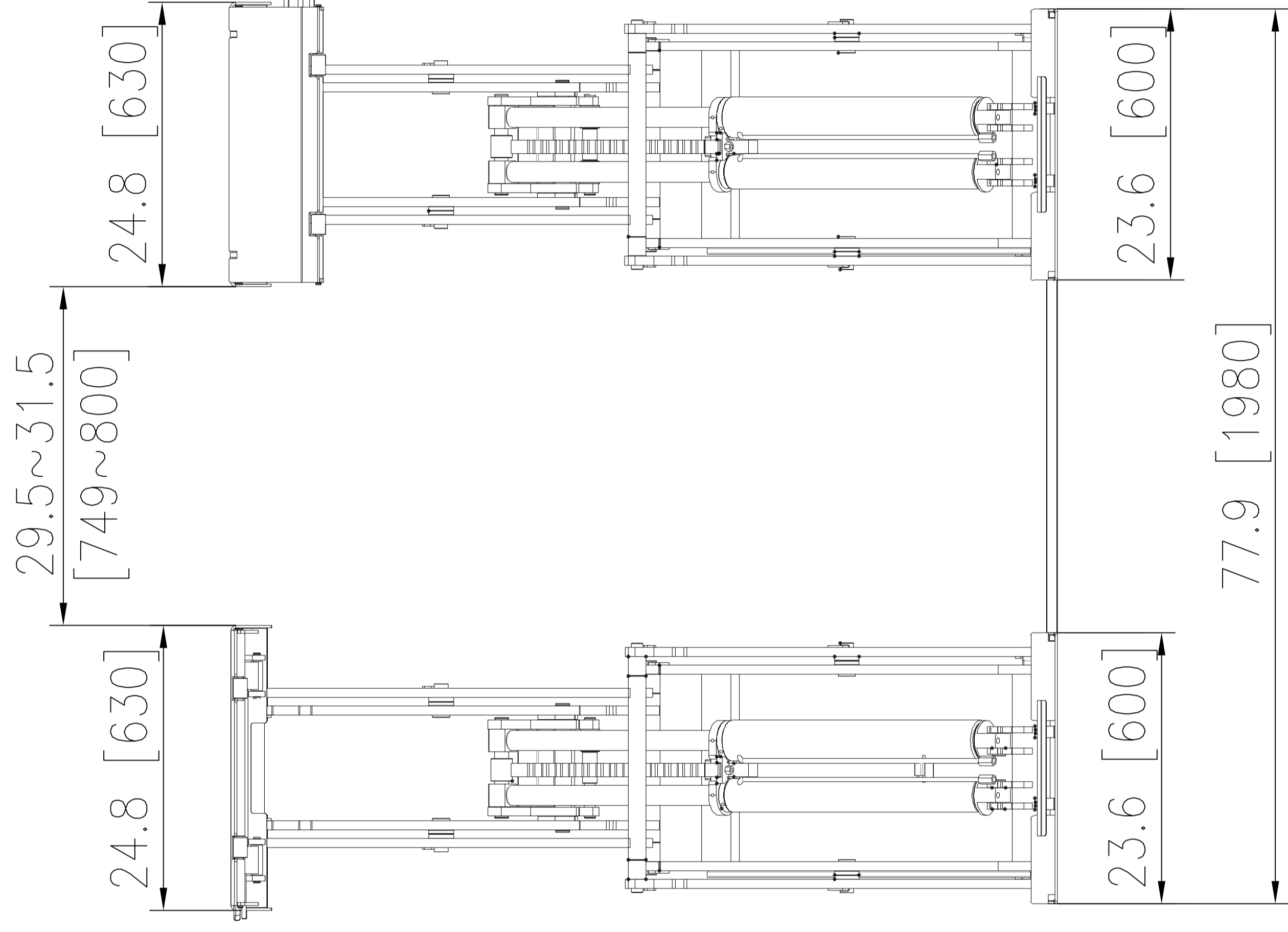
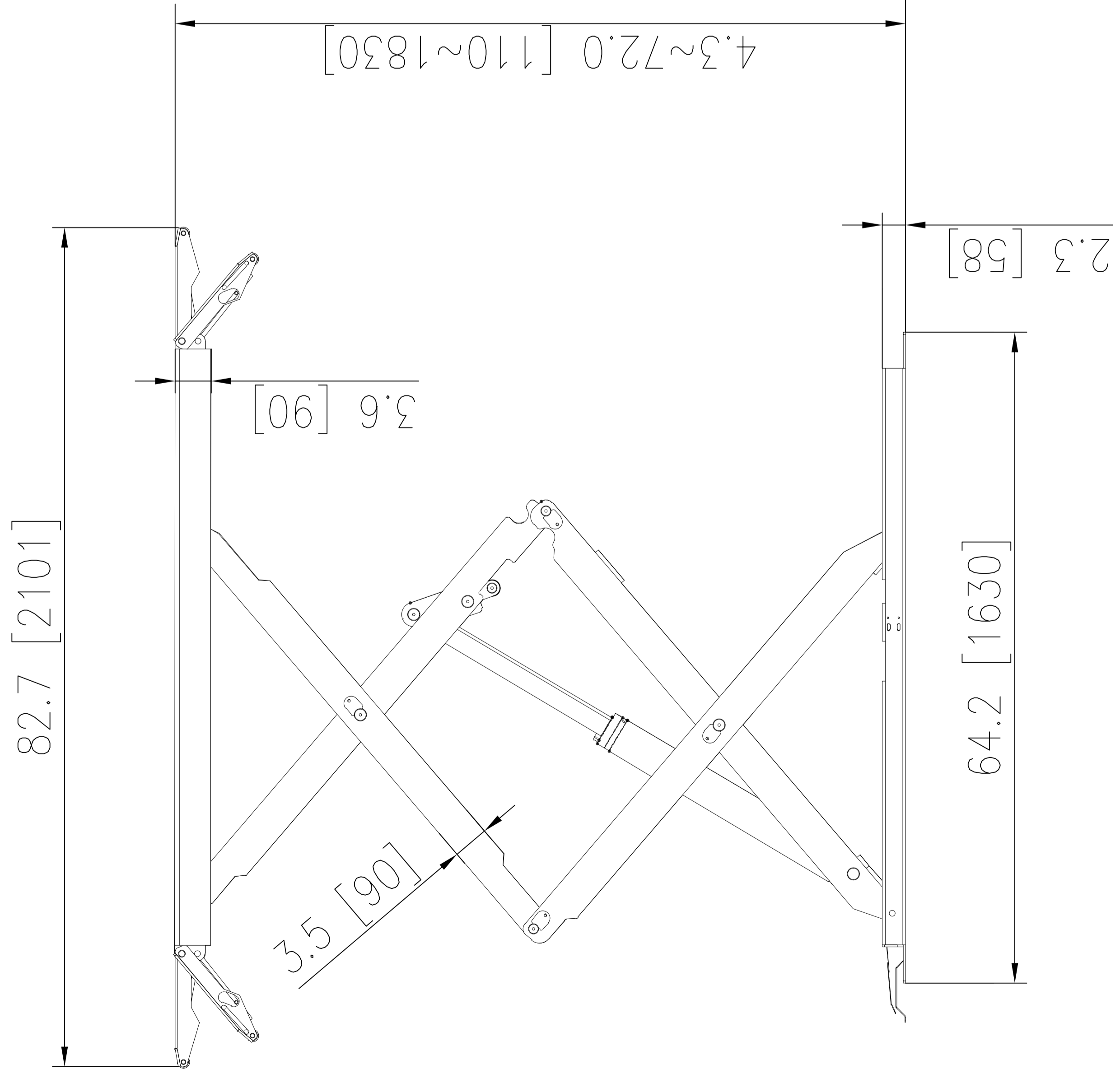

**Daytona**  
AUTOMOTIVE EQUIPMENT

**LHS7**

APPROVED FOR PRODUCTION  
 Certified Engineer: *Ruying Li*  
 Cert. No.: B093201001233320001  
 Date: 26.10.2024

## **Contents**

**Manufacture and service**

**Packing, transport and storage**

**Introduction**

- **Description of the machine**
- **Technical specifications**
- **Safety**
- **Installation**
- **Adjustment**
- **Operation**
- **Maintenance and care**
- **Troubleshooting**
- **Accessory**

**PACKING, TRANSPORT AND STORAGE**

**PACKING (Picture 1)**

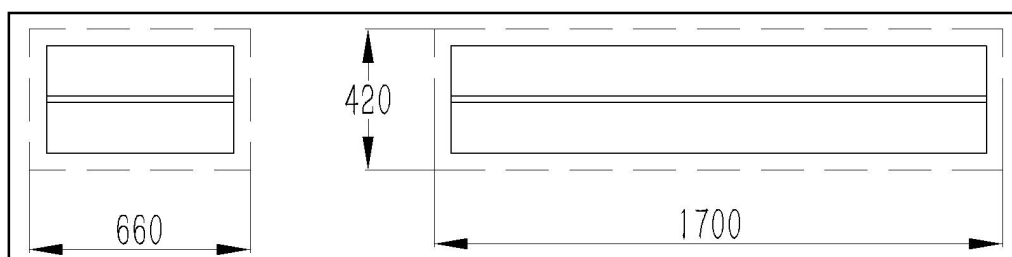

Picture 1

**Transport (Picture 2)**



**Packing can be lifted or moved by lift trucks, cranes or bridge cranes. In case of slinging, a second person must always take care of the load, in order to avoid dangerous oscillations.**

During loading and unloading operation, goods must be handled by vehicles or ships.

At the arrival of the goods, verify that all items specified in the delivery notes are included.

If finding missing parts, possible defects or damage due to transport, one should examine damaged cartons according to 'Packing List' to verify the condition of damaged goods and missing parts, also the person in charge or the carrier must be immediately informed.

The machine is heavy goods! Don't take manpower load and unload and transporting way into consideration, the safety of working is important.

Furthermore, during loading and unloading operation goods must be handled as shown in the picture. (Picture 2)

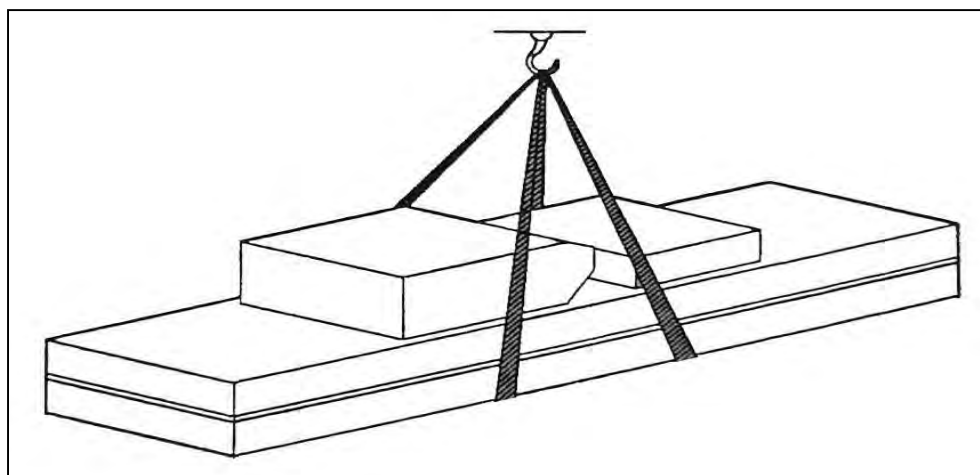

Picture 2

**Storage:**

-The machine equipment should be stocked in the warehouse, if stocked outside should do the disposal well of waterproof.

-Use box truck in the process of transport, use container storage when shipping.

-The control box should be placed perpendicularly during the transport; and prevent other goods from extrusion.

-The temperature for machine storage: -25°C- 55°C

## Manual Introduction

This manual has been prepared for workshop personnel expert in the use of the lift operator and technicians responsible for routine maintenance fitter.



Workers should read the 'Maintenance & User Manual' carefully before carrying out any operation with the lift. This manual contains important information regarding:

- The personal safety of operators and maintenance workers.
- Lift safety,
- The safety of lifted vehicles



### CONSERVING THE MANUAL

This manual is an integral part of the lift.

The manual must be kept in the vicinity of the lift, so that the operator and maintenance staff must be able to locate and consult the manual quickly and at any time.

Attentively reading Chapter 3, which contains important information and safety warning, is particularly recommended.

### The lift is designed and manufactured according to European Standard



The lifting, transport, unpacking, assembly, installation, starting up, initial adjustment and testing, extraordinary maintenance, repair, overhauls, transport and dismantling of the lift must be performed by specialized personnel from the licensed dealer authorized by the manufacturer.

The manufacturer declines all responsibility for injury to persons or damage to vehicles or objects when any of the above mentioned operations has been performed by authorized personnel or when the rack has been subject to improper use.



This manual indicates: the operative and safety aspects that may prove useful to the operator and maintenance worker. For better understanding the structure and operation of the lift and for best use of the same, workers must read the 'Maintenance & Use Manual' carefully before carrying out it.

In order to understand the terminology used in this manual, the maintenance and repair activities, the ability to interpret correctly the drawings and descriptions contained in the manual and be the country in which the machine has been installed.

The same applies to the maintenance and the maintenance fitter must also possess specific and specialized knowledge both in mechanical and engineering field.

- OPERATOR: person authorized to use the lift
- MAINTENANCE FITTER: person authorized for routine maintenance of the lift.



Manufacturer owns the right to make little change for the manual owing to the improvement of technology.

**Chapter 1 DESCRIPTION OF THE MACHINE****Machine Application:**

This lift can lift each kind of vehicle whose weight is less than 3000kg, and is suitable for use in vehicle tests, maintenance, and caring for automobiles, which is particularly suitable for use in the basement or on the floor, without construction and hole.

**Structure Features:**

- Use hidden and thin scissor structure, dispense with construction and ground hole, the occupation is small.
- Independent control box, low-voltage controlling, good security.
- Hydraulic volume and in-phase cylinder, the synchronization of platform.
- Own the double safety equipment of hydraulic lock and mechanical pawl, on the safe side.
- Own protection of safety valve and burst-proof equipment for hydraulic failure and over loading. So when the oil pipe bursts, the machine will not fall quickly.
- Own manual lowering operation when the power is cut off.

**Equipment:**

- Machine basement (The position and space of equipment installation)
- Machine frame (The main structure of lift and insurance institution)
- Control box (Machine-controlled part)

**Basic structure**

The machine basement is made of cement and concrete

**Frame**

Make of steel connecting rod, main lifting platform, sliding board, pneumatic double tooth, and hydraulic oil tank.

**Control box**

Under the control box is hydraulic oil tank and hydraulic pump, valve and other control system. On the control box is electrical system.



Scissor lift is designed and built to lift all kinds of vehicles, all other use are unauthorized. In particular, the lift is not suitable for washing spray work. And not lift the vehicle whose weight exceeds the maximum weight.

## Main technical parameter

Item	Parameter
	With extension ramp
Drive	Electrical hydraulic
Lifting weight	3500kg
Lifting height	1830mm
Platform initial height	110mm
Platform length	1495-2100mm
Platform width	630mm
Lifting time	≤50s
Descent time	≤60s
Whole machine length	2100mm
Whole machine width	2055mm
Weight	825kg
Voltage	AC 400V or 230V ± 5% 50Hz/(60 HZ--optional choose), For detail please see name plate on control box!
Whole machine power	2.2kw
Hydraulic oil	18L corresponds to wearable hydraulic oil (provide by user) (provide for oneself)
Air pressure	4~6 kg/cm <sup>2</sup>
Working temperature	5-40℃
Working humidity	30-95%
Noisy level	< 80db
Installation height	Height above sea level ≤1000M
Storage temperature	-25℃~55℃
Installation place	Indoor

Table 1

Lift dimension picture:

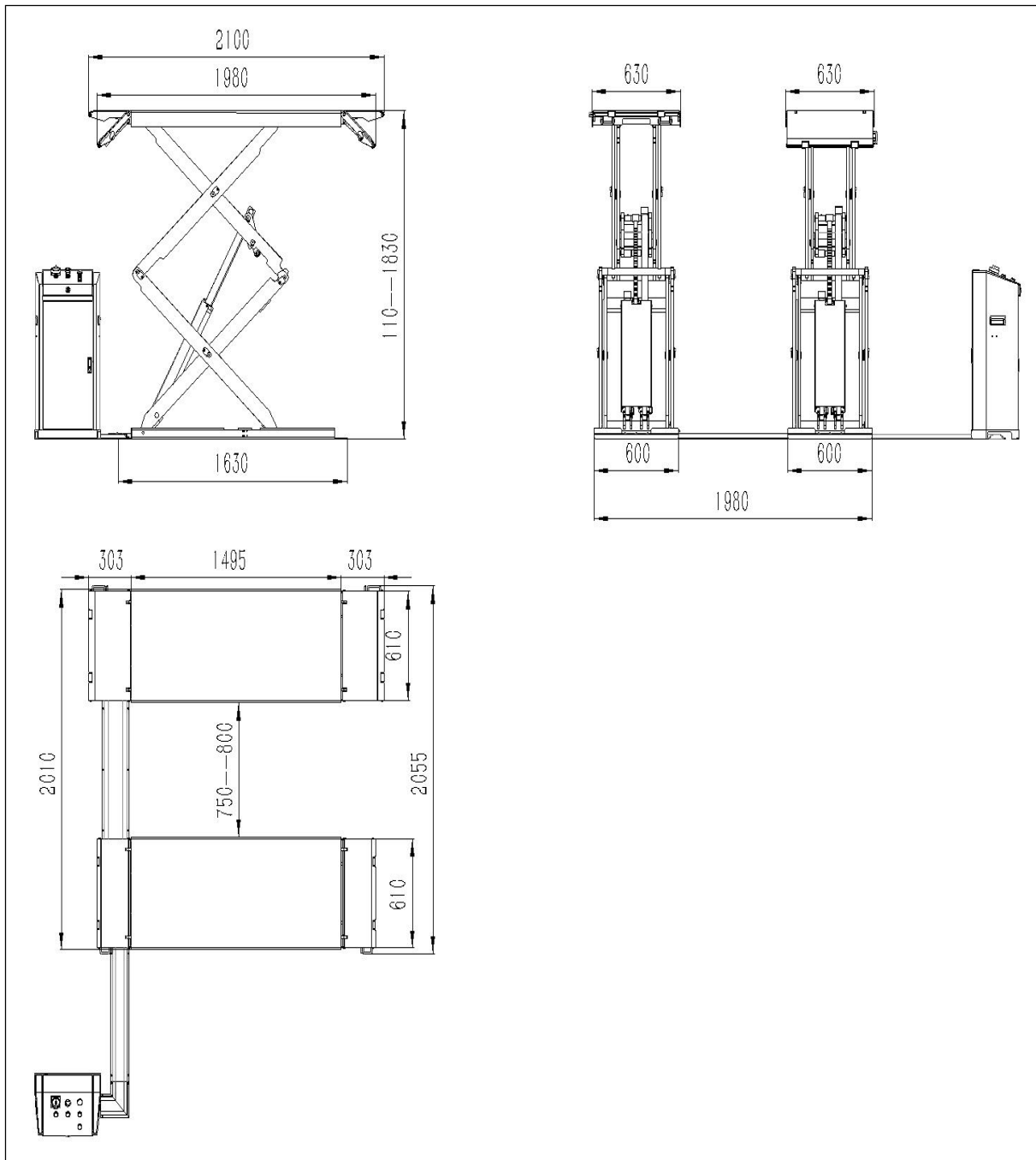

Picture 3

**Motor**

Type.....	Y90L
Power.....	2.2kw
Voltage.....	AC 400 or 230V ±5%
Power supply.....	400VAC: 5A .....230VAC: 10A
Frequency...50Hz (or 60 HZ----	special ordered)
Poles.....	4
Speed.....	1450 rpm/min
Building shape.....	B14
Insulation class.....	F

**Pump**

Type.....	gear pump
Model.....	P4.3
Max flux.....	4.3 cc/r(50HZ)/3.2 cc/r(60HZ)
Joint type.....	direct joint
Overflow valve	
Setting pressure.....	280 bar
Adjustable working pressure.....	150~300 bar

**Supply at the same time**

- Connect to the power supply jack of control box (400V or 230V)
- Connect to the compressed air-entering pipe of control box (  $\phi 8 \times 6\text{mm}$  )

**Requirements:**

- Concrete type 425#, the period of desiccation is 15 days
- Clean the basic layer, thickness of concrete  $\geq 150\text{mm}$ , the leveling of whole length  $\leq 5\text{mm}$

**INSTALLATION SCHEME FOR SCISSOR LIFT**

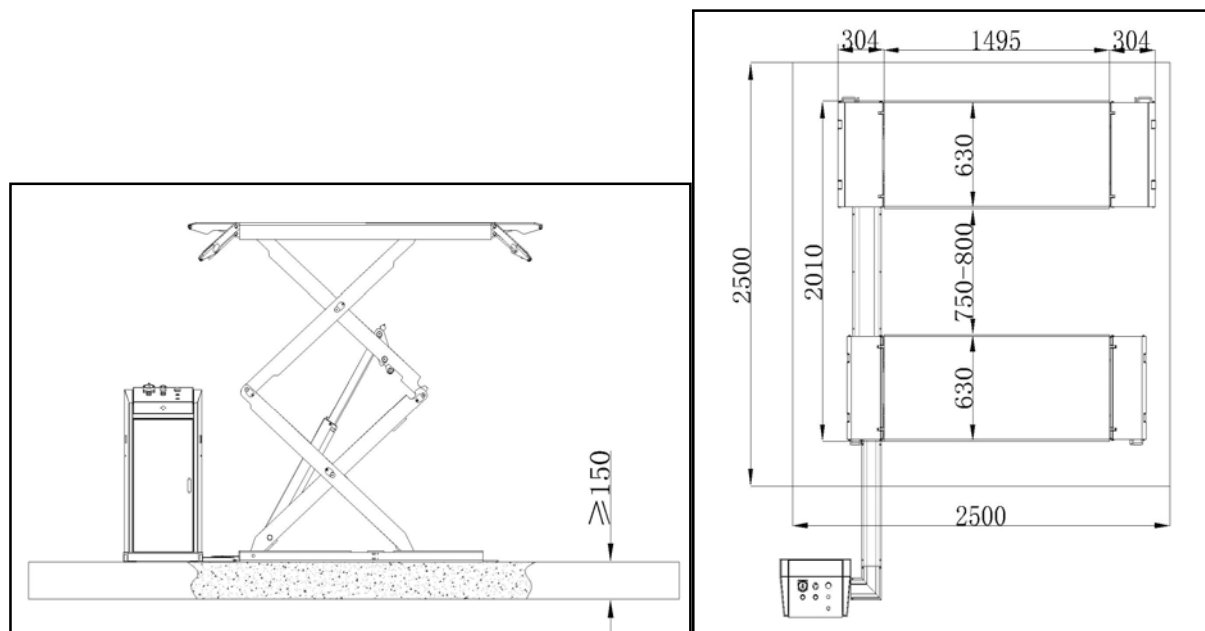

Picture 4(Ground drawing)

The control box can be placed on the left or right.



Note: The foundation of the end of the lift platform P1, P2 is the structure of concrete. When the thickness of inside level ground is less than 150mm, the end of P1, P2 should be irrigated the

acreage: 2500×2500mm and thickness of concrete  $\geq 150$ mm

The basic thickness of concrete and leveling are keys, shouldn't egregiously expect the ability of level adjustment of machine-self.



THE LOWER PARTS OF THE VEHICLES UNDERBODY COULD INTERFERE WITH STRUCTURAL PARTS OF THE LIFT, TAKE PARTICULAR PARTS OF THE SPORTS-CAR.

The lift will also handle customized or non-standard vehicles provided they are within the maximum specified carrying capacity.

Also the personnel safety zone must be defined in relation to vehicle with unusual dimensions.

### Chapter 3 SAFETY



Read this chapter carefully and completely since important information for the safety of the operator or others in case of improper use of the lift is included.

In the following text there are clear explanations regarding certain situations of risk or danger that may arise during the operation or maintenance of the lift, the safety device installed and the correct use of such systems, residual risks and operative procedures to use (general specific precautions to eliminate potential hazards).



Lifts are designed and built to lift vehicles and hold them in the elevated position in an enclosed workshop. All other uses of the lifts are unauthorized. In particular, the lifts are not suitable for:

- Washing spray work;
- Creating raised platforms for personnel or lifting personnel;
- Use as a press for crushing purposes;
- Use as elevator;
- Use as a lift jack for lifting vehicle bodies or changing wheels.



The manufacturer is not liable for any injury to persons or damage to vehicles and other property caused by the incorrect and authorized use of the lifts.

During lifting and descent, the operator must remain in the control station as the diagrams illustrated.

As the diagrams illustrated, the presence of persons inside the danger zone indicated is strictly prohibited. During operations persons are admitted to the area beneath the vehicle only when the vehicle is already in the elevated position, when the platforms are stationary, and when the mechanical safety devices are firmly engaged (e.g.: the safety gear is completely locked).



**DO NOT USE THE LIFT WITHOUT PROTECTION DEVICES OR WITH THE PROTECTION DEVICES INHIBITED.**

**FAILURE TO COMPLY WITH THESE REGULATIONS CAN CAUSE SERIOUS INJURY TO PERSONS, AND IRREPARABLE DAMAGE TO THE LIFT AND THE VEHICLE BEING LIFTED.**

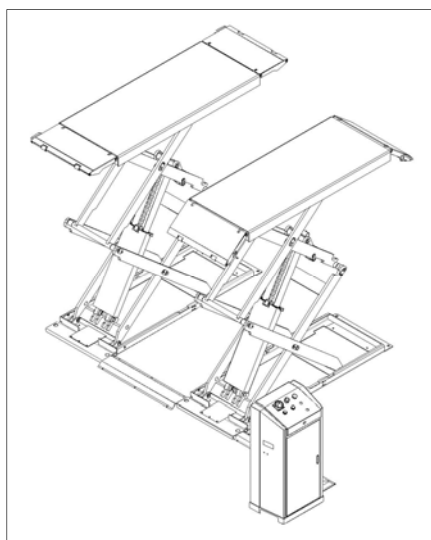

Picture 5

### Chapter 3 SAFETY

#### GENERAL PRECAUTIONS



The operator and the maintenance fitter are required to observe the prescriptions of safety regulation in force in the country of installation of the lift.

Furthermore, the operator and maintenance fitter must:

- Always work in the stations specified and illustrated in this manual;
- Never remove or deactivate the guards and mechanical, electrical, or other types of safety devices;
- Read the safety notices placed on the machine and the safety information in this manual.



In the manual all safety notices are shown as follows:

**WARNING:** indicates following operations that are unsafe and can cause minor injury to persons and damage the lift, the vehicle or other property.



**CAUTION:** indicates possible danger that can result in serious injury to people and damage property.



**RISK OF ELECTRIC SHOCK:** a specific safety notice placed on the lift in areas where the risk of electric shock is particularly high.

#### RISK AND PROTECTION DEVICES

We shall now examine the risks that operators or maintenance fitters may be exposed to when the vehicle is standing on the platforms in the raised position, together with the various safety and protection devices adopted by the manufacturer to reduce all such hazards to the minimum:

For optimal personal safety and safety of vehicles, observe the following regulations:

- Do not enter the danger areas when vehicles are being lifted. (Picture 5)
- Make sure the vehicle is positioned correctly. (Picture 6)
- Be sure to lift only approved vehicles, never exceed the specified carrying capacity, maximum height, and projection (vehicle length and width);
- Make sure that there is no person on the platforms during up and down movements and during standing.

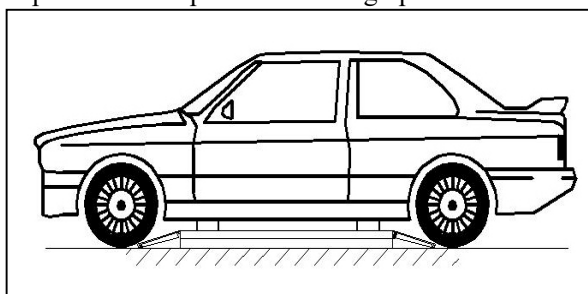

**GENERAL RISKS FOR LIFTING OR DESCENT:**

The following safety equipment are used to protect over loading or the possibility of engine failure.

In the condition of over loading, the overflow valve will open and directly return oil to the oil tank. (See Picture 7)

Each bottom of oil cylinder is equipped with antiknock valve. When the oil pipe is burst in the circuit of hydraulic pressure, the relevant

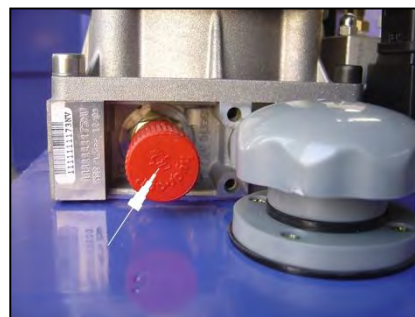

Picture 7 (overflow valve)

**Chapter 3 SAFETY**

antiknock and overflow valve will work and limit the speediness of platform. (See Picture 8)

Safety tooth and gear module are parts which guarantee the safety of personnel beneath the machine in failure condition of other protections. So make sure the integrity of gear module and that the safety tooth has occluded completely. (Picture 9)



Picture 8



Picture 9



There is nothing abnormal should be left on the safety modules to prevent safety gear from occlude normally.



**RISKS FOR PERSONNEL**

This heading illustrates potential risks for the operator, maintenance fitter, or any other person present in the area around the lift, result from incorrect use of the lift.



**RISKS FOR EXTRUSION**

During up and down operations, personnel leave the said area without following the rule and instruction.

During up and down operations, no person is admitted to work beneath the movable parts of the lift, should work in the safe zone. (Picture 5)



**RISK OF IMPACT (Picture 10)**

Before the operator begins up and down movements, make sure that there are no personnel inside the danger zone. When, due to operational reasons, the lift is stopped at relatively low elevations (lower than 1.75m above the ground) personnel must be careful to avoid impact with parts of the

machine not marked with special colors.

**RISK OF FALLING OFF (PERSONNEL)**



During up and down operations, personnel are prohibited from entering the platforms and the vehicle to avoid falling off.

**RISK OF FALLING (VEHICLE)**



This hazard may arise in the case of incorrect positioning of the vehicle on the platforms, overweight of the vehicle, or in the case of vehicles of dimensions that are not compatible with the capacity of the lift.

When the platform is being tested, the vehicle engine can not be turned on.



There is nothing should be placed on the lift-lowering area and the movable parts of the lift.

**Chapter 3 SAFETY**

**RISK OF SLIPPING (Picture 11)**



The floor caused by lubricant contamination of around the lift. The area beneath and immediately surrounding the lift and also the platforms must be kept clean. Remove any oil spills immediately.

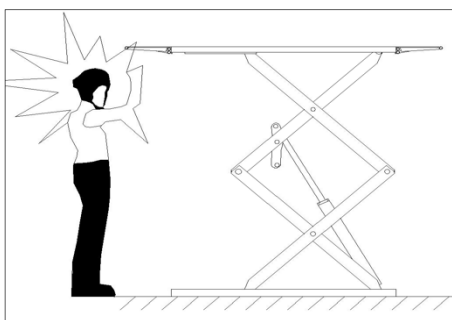

Picture 10

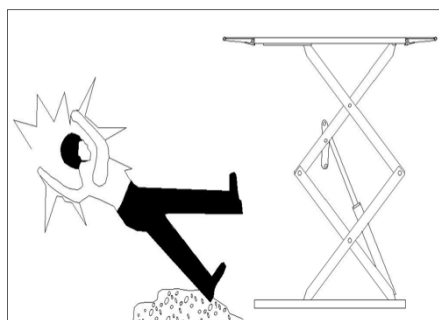

Picture 11

**RISK OF ELECTRIC SHOCK**



Risk of electric shock of the areas of insulated in electric equipment were shattered.

Do not use jets of water, steam solvents or paint next to the lift, and take special care to keep such substances clear of the electrical control panel.

**RISKS RELATED TO INAPPROPRIATE LIGHTING**



The operator and the maintenance fitter must be able to assure that all the areas of the lift are properly and uniformly illuminate compliance with the laws in force in the place of installation.

During up and down operations, the operator should continually observe the lift and can operate it only in the position of operator. When lifting and lowering the vehicle, the cushion needs being put in the bottom of chassis.



The handling of safety devices is strictly forbidden. Never exceed the maximum carrying capacity of the lift, make sure the vehicles to be lifted have no load.



It is therefore essential to adhere scrupulously to all regulations regarding use, maintenance and safety contained in this manual.

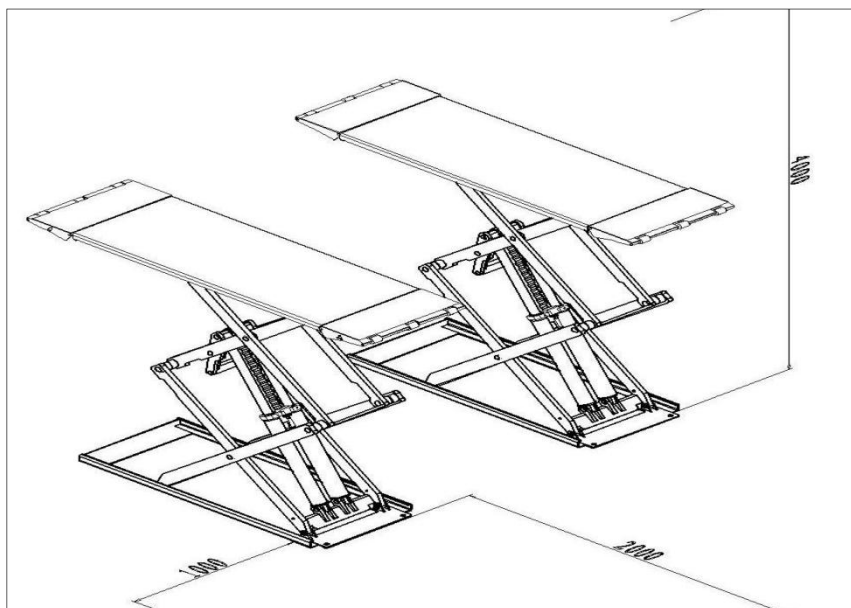

Picture 12

- All parts of the machine must be uniformly lit with sufficient light to make sure that the adjustment and maintenance operations can be performed safely, and without reflected light, glare that could give rise to eye fatigue.
- The condition of the delivered goods should be checked before the lift is installed.
- Moving and installing lift should follow the process as the picture instructs.

The transport and storage of machine refers to “TRANSPORT AND STORAGE” on page 4.

**Chapter 4 INSTALLATION**

**Platform Installation:**

- Place two platforms on the position of the location.
- The bottom of oil cylinder is located in the frontage of machine (the direction of getting on the vehicle)
- Use fork car or other lifting equipment to lift the platform (Picture 13) and make sure that the safety equipment of machine is both turned on and locked.

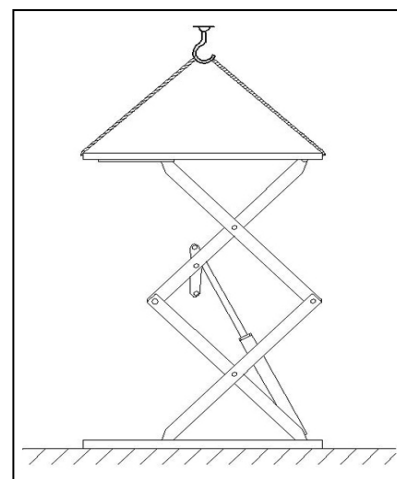

Picture 13



To avoid failure of machine safety equipment, can insert a wood in the middle part of joint-pole.

Prohibit working beneath the lift when hydraulic system is not completely equipped with hydraulic oil and take the action of up and down operations.

-When moving the lift platform, adjust the space between two platforms; make sure that the two platforms are parallel.

**LINE CONNECTION**

Connect the electrical and oil line according to ‘the electrical diagram’ and ‘oil pipe connection diagram’.



It's not allowed to damage oil pipe, wire, and air pipe.

In the process of connecting oil pipe and air pipe, pay particularly attention to the protection of

pipe tie-in to prevent abnormal thing from entering oil loop, then damaging hydraulic system.

**ELECTRIC CIRCUIT CONNECTION:**

Follow the stated line- pathway and line-number of the ‘electrical diagram’ to connect electric circuit.



Only skilled person is allowed to perform the operations.

-Open the control box front cover.

-**Connection of power supply:** the 400V three-phase and five-line connection wires (3×2.5 mm<sup>2</sup> + 2×1.5 mm<sup>2</sup> cable wire) for power supply are connected to control box L1, L2, L3, N and entering-wire terminal. The PE ground wire is connected under the bolt marked ground firstly (Picture 14) and then connected under the bolt marked ground of two platforms.

-If the lift is operated at 230V three-phase, change the connection on the transformer and motor. (Picture 15)

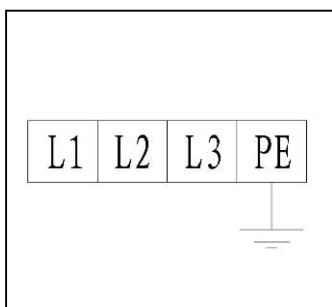

Picture 14

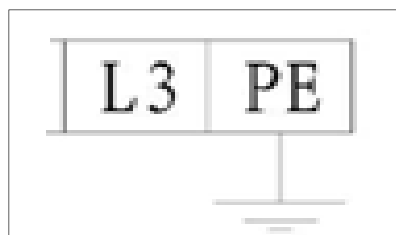

Picture 15

**Chapter 4 INSTALLATION**

-**Connection of up limit switch(SQ1) (Picture 16):**

For detail connection, please see the electrical drawing.

-**Connection of lower limit switch(SQ2) (Picture 17):**

For detail connection, please see the electrical drawing.

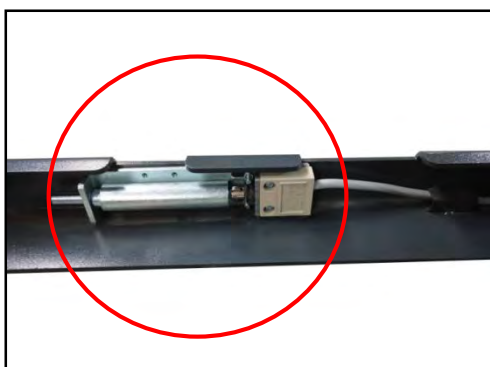

Picture 16 (up limit switch) Optional



Picture 17 (lower limit switch)

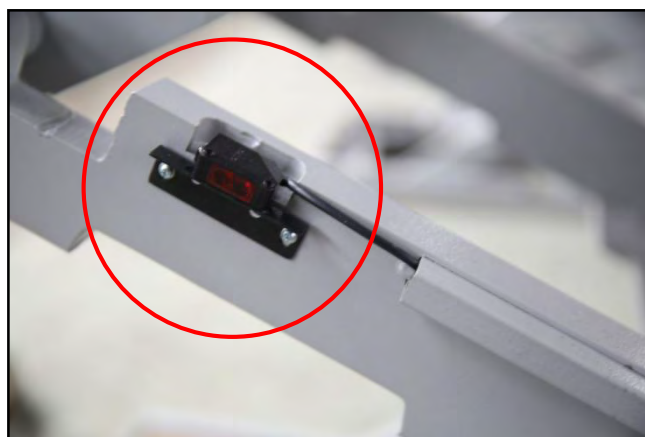

Picture 18 (photocell sensor) Optional

-**Connection of photocell (PH)**(Picture 18): For detail connection, please see the electrical drawing.

**Oil PIPE CONNECTION:**

Follow “oil pipe diagram “to connect the oil pipes.

Only skilled and authorized person is allowed to perform the operations. And pay particularly attention to the protection of oil pipe fitting



-Following oil pipe number to lead the oil pipe out from oil block of control box and then connect them to the cylinder. (Refer to “oil pipe diagram”)

-Connect the air pipe from the oil block to the oil return loop of cylinder.

-When connecting oil pipes, pay attention to the protection of oil pipe tie-in to prevent impurities from entering hydraulic circuit.



When connect the oil pipes, be careful not to mistake each oil pipe number.

During the standard installation, control box is in the nearside of vehicle-entering direction. If placed on the right should adjust relevant oil pipe.

**Chapter 4 INSTALLATION**



In the process of windpipe installation, the windpipe can not be folded or tied to avoid that the air loop is not smooth or it is jammed.

Before leading the compressed air supply pipe to the air supply lock latch of solenoid air valve inside the control box, should extra install grease separator to separate compressed air, avoiding the failure of pneumatic cell action.

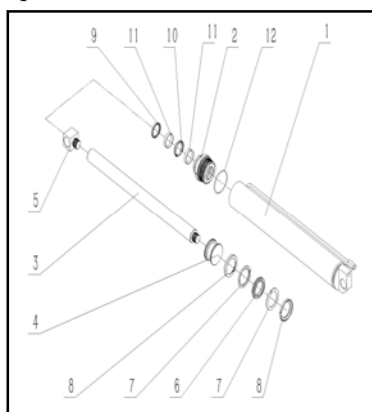

Picture 20

**Add oil and check the order of phase.**

After installing lift as Picture 3 required and connecting hydraulic circuit and electric circuit , operate it as following:

-open the hydraulic oil tank, add 18L of hydraulic oil into the oil tank, the hydraulic oil is provided by the user.



Make sure the clean of hydraulic oil, prevent any impurity into the oil line, lead the digest of the oil line and no working of the solenoid valve.

-Turn "PHOTOCELL" key switch to "OFF" position.

-Turn the "MAIN SWITCH" to turn on power, and click the 'UP' button, check whether the motor turns clockwise (looking downward), if not turn off "MAIN SWITCH" button, change the phase of the motor.

-Turn on air supply.

**When turn on power, the high voltage will exist in the control box, only authorized person can operate it.**

**Oil make-up adjustment**

1. Ensure that the machine is properly installed, the power supply is normal, the air source is functioning, and the rotation direction of the power unit is correct.
2. Confirm that the oil pipes are installed correctly. ( see picture 26 )
3. Press the "UP" button: the power-unit motor starts and raises both platforms. When the platform nearest the control cabinet reaches its upper limit and the machine stops climbing, release the "UP" button.
4. Press the "LEVELING" button don't release , then press "UP" again. Both platforms will resume lifting. Wait until both platforms reach their absolute top position, then stop pressing and wait 1 minute (see picture 23).
5. Press the "LEVELING" button again, then press the "UP" button, let the motor start for 1 minute, and release these two buttons.
6. Press the "DOWN" button until both platforms settle at their lowest position.
7. Possible after-leveling issue

After leveling is complete, pressing the UP button may not start the machine. This is usually because the upper-limit switch has not reset. Simply short the two wires to the limit switch momentarily to let the motor start and lift, then manually check that the limit switch returns freely.

**Check:** whether the locations of two safety-pawl equipment are agile and reliable, oil leakage of the oil line and air tightness of the air loop.

**GROUND BOLTS INSTALLATION:**



The ground bolts installation must start after the expiry date on the maintenance of concert, otherwise, it will affect the quality of solidity.

- Adjust the parallel of the platform and the distance of two platforms as Picture 4 requires.
- Fix the anchor bolts with a percussion electric drill (percussion drill bit is of 16), drill to 120 mm depth hole and clean the hole. (Picture 21)
- Use light hammer to install the ground bolts into the hole (need not install the Central expanded nail of ground bolts, install it after level adjustment.)



Picture 21

**Chapter 5 ADJUSTMENT**

**Level adjustment:**

- By using a level bar and the horizontal pipe and adjusting the adjustment screws at tow sides of the base plate.
- If platform unevenness is resulted from basic unevenness, use iron block to fill up the low place.
- After level adjustment, insert the central expanded nail of ground bolts and use heavy hammer to hammer it.
- Screw down the ground bolts cap.

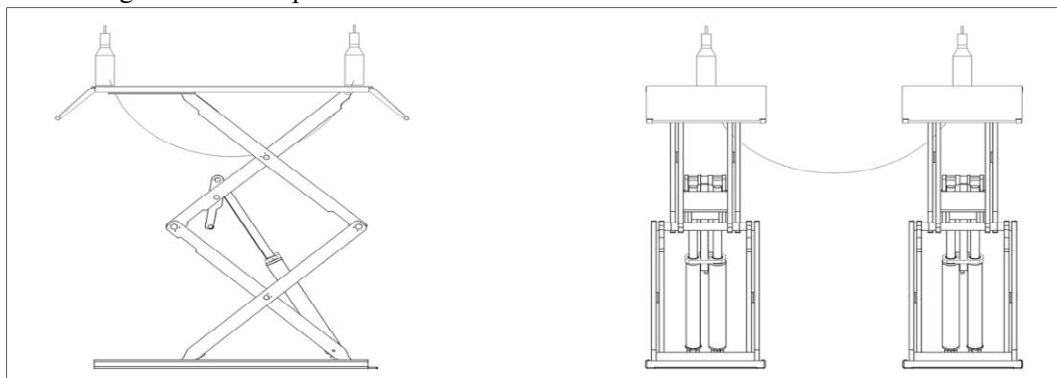

Picture 22



When the expiry date on the maintenance of concrete hasn't arrived, one can not install the central expanded nail of ground bolts.

The gap between the base plate and ground after adjustment must be filled with iron plate or concrete.

**No load of main machine test:**

- Turn on the power QS.
- Press "UP" button, pay attention to the synchronization and placidity of the lifting.
- Check whether lock latch is correctly located.
- Check whether the oil line and the air line are leakage.



When testing the lift, no person or other things are allowed to stand or be put near the two sides or beneath the machine. If any abnormal is found, press button “**EMERGENCY STOP**” to stop it immediately. After clearing obstacles, do the test again.

**Load of machine test:**

- Drive the vehicle whose weight does not exceed maximum lift weight to the platform, and then the driver leaves it.
- Fit the rubber cushioning pad onto the headrest.
- Press ‘UP’ button, lift the platform and pay attention to the synchronization and placidity of the lifting.
- Check whether safety pawl is correctly located.
- Check whether the oil line and the air line are leakage.



When beginning load of machine test, no person or other things are allowed to stand or be put near the two sides or beneath the machine.

Test vehicle whose weight doesn't exceed maximum lift weight.

Check whether the oil line and the air line are leakage. If any abnormal is found, press button ‘**EMERGENCY STOP**’ to stop it immediately. After clearing obstacles, do the test again.

**Chapter 6 OPERATION**



**Only skilled and having been trained personnel is allowed to perform the operations. Check proceedings as following.**

**Operation Notices:**

- Clear obstacles around the lift before operation.
- During lifting or lowering, no person is allowed to stand near the two sides and beneath the machine, and no person is allowed on the two platforms.
- Avoid to lifting over weight vehicles or other goods.
- When lifting vehicle, the chassis of the vehicle should be filled up with rubber cushion.
- Pay attention to the synchronization of the lifting and lowering. If any abnormal is found, stop the machine timely, check and remove the trouble.
- Lift the platforms a little bit before lowering, to ensure that two safety pawls and safety teeth have been disengaged completely. If not, stop lowering.
- When the equipment is not used for a long time or over night, the machine should be lowered to the lowest position on ground, and remove vehicle, and cut off power supply.

**Instructions on electric operation: (see the operation panel)**

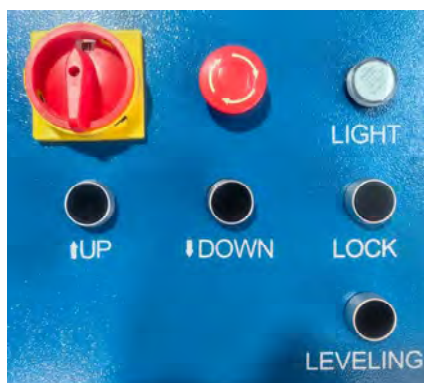

Picture 23

**LIFTING:**

- Press “UP” button, the platform is being lifted. When reach the up limit switch, the platforms will stop automatically.
- Release it, the platforms stop lifting.

**LOCK:**

- Press ‘LOCK SEC. DOWN’ button to lock the platform when the lift is above the lower limit switch action position(about 330mm above floor).

**DESCENT:**

- Press ‘DOWN’ button, the buzzer rings and platform begins to lower. During the whole lowering process, the buzzer rings all the time.
- Release the button, platforms stop descending and the safety pawl falls on the safety gear.
- But when keep pressing “DOWN” button, the platforms descend and will stop automatically on about 330mm high when reach the lower limit switch. Release it and press ‘LOCK SEC. DOWN' button, the platforms will descend again.

**EMERGENCY STOP:**

- When the machine has abnormal during car maintenance, push ‘EMERGENCY STOP’ button and lock, and cut off all the operation circuit, other operation can not be work.

**Chapter 6 OPERATION**

**NOT IN-PHASE STOP MACHINE:**

When two platforms are not at the same height during lifting and lowering operations, photo-electricity leveling equipment will stop working immediately. According to the following process to adjust the platform level, only after two platforms are at the same height can put them into use.



**Oil make-up “adjust” operation (normal service period):**

After completion of machine installation and adjustment in the application process, the right platform is lower than the left one because of air in the oil cylinder not being excluded completely normal loses or leakage of the hydraulic oil.



When conducting oil make-up operation, the platforms must not load.  
Adjustment process is as approach ‘5’ and ‘6’ of ‘Oil make-up adjustment’.



**EMERGENCY MANUAL OPERATION FOR LOWERING (POWER FAILURE):**

When lowering through manual operation, should observe the condition of platform at any time because there is vehicle on the platforms. If there is something abnormal, screw down oil loop valve immediately.

The process of manual operation:

- Firstly lift two safety pawls of platform and use thin iron bar to fill up it.
- Switch off the power button (avoid abruptly incoming electricity). Open the back cover of control box to find the electromagnetic valve A for lowering.
- Loosen manual oil loop stud at the end of lowering electromagnetic descent valve core, and then the platforms begin to descend.
- After the machine has been descended, screw down descent valve’s stud timely. The process of manual lowering comes to the end.

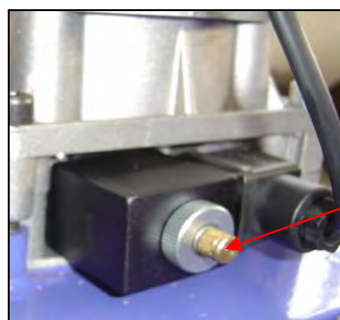

Picture 24

## Chapter 7 MAINTENANCE AND CARE

### **Skilled personnel only are allowed to perform the operations.**



-All bearings and hinges on this machine must be lubricated once a week by using an oilier.

-The safety gear, the upper and lower sliding blocks and other movable parts must be lubricated once a month.

-The hydraulic oil must be replaced one time each year. The oil level should always be kept at upper limit position.



-The machine should be lower to the lowest position when replace hydraulic oil, then let the old oil out, and should be filtering the hydraulic oil.

-Each team checks the operational responsiveness and reliability of the pneumatic safety equipment.

**Chapter 8 FAILURE AND TROUBLESHOOTING**



Skilled personnel only are allowed to perform the operations.

**Failure and Troubleshooting**

<b>Failure</b>	<b>Cause</b>	<b>Troubleshooting</b>
The motor does not run in lifting operation.	① Connection of power supply wires is not correct.	Check and correct wire connection
	② The AC contactor in the circuit of the motor does not pick up.	If the motor operates when forcing the contactor down with an isolation rod, check the control circuit. If the voltage at two ends of the contactor coil is normal, replace the contactor.
	③ The limit switch is not closed.	Check the limit switch, wires and adjust or replace the limit switch.
In lifting operation, the motor runs, but there is no lifting movement	① The motor turns reverse.	Change the phases of the power supply wires.
	② Lifting with light load is normal but no lifting with heavy load.	The set safe pressure of the over-flow valve may be increased by turning the set knob right ward slightly. The spool of the lowering solenoid valve is stuck by dirt. Clean the spool.
	③ The amount of hydraulic oil is not enough.	Add hydraulic oil.
	④ The “stop valve” is not closed.	Screw down the “stop valve”.
When press “Lower” button, the machine is not lowered	① The safety pawl are not released form the safety teeth.	First lift a little and then lowering
	② The safety pawl is not lifted.	The air pressure is not enough, the safety pawl is stuck or the air pipe is broken off, adjust pressure, check the air pipe and replace it.
	③ The solenoid air valve does not work.	If the solenoid air valve is energized, but does not open the air loop, check or replace the solenoid air valve.
	④ The descent valve is energized but does not work.	Check the plug and coil of the descent valve and check the right turn tightness of its end copper nut and so on.
	⑤The “antiknock valve” is blocked.	Remove the “antiknock valve” from the oil supply hole at the bottom of the oil cylinder, and clean the “antiknock valve”.
The machine lowers extremely slowly under normal loads.	①The hydraulic oil has too high viscosity or frozen, deteriorated (in Winter).	Replace with hydraulic oil in accordance with the instruction book.
	② The “antiknock valve” for preventing oil pipe burst is blocked.	Remove or close air supply pipe and thus lock the safety pawl of the machine without lifting of the safety pawl. Remove the “antiknock valve” from the oil supply hole at the bottom of the oil cylinder, and clean the “antiknock valve”.
The right and left platforms are not synchronous and not in the same height.	① The air in the oil cylinder is not vent completely.	Refer to “Oil Make-up adjustment”.
	② Oil leakage on oil pipe or at its connections.	Tighten oil pipe connections or replace oil seals and then make-up oil and adjust levelness.
	③ The “stop valve” can not be closed tightly and almost make-up oil and adjust every day.	Replace oil "stop valve" and then make-up oil and adjust.
Noisy lifting and lowering.	①Lubrication is not enough.	Lubricate all hinges and motion parts (including piston rod) with machine oil
	②The base or the machine is twisted.	Adjust again the levelness of the machine, and fill or pad the base.

Table 2

## hydraulic pressure elements diagram

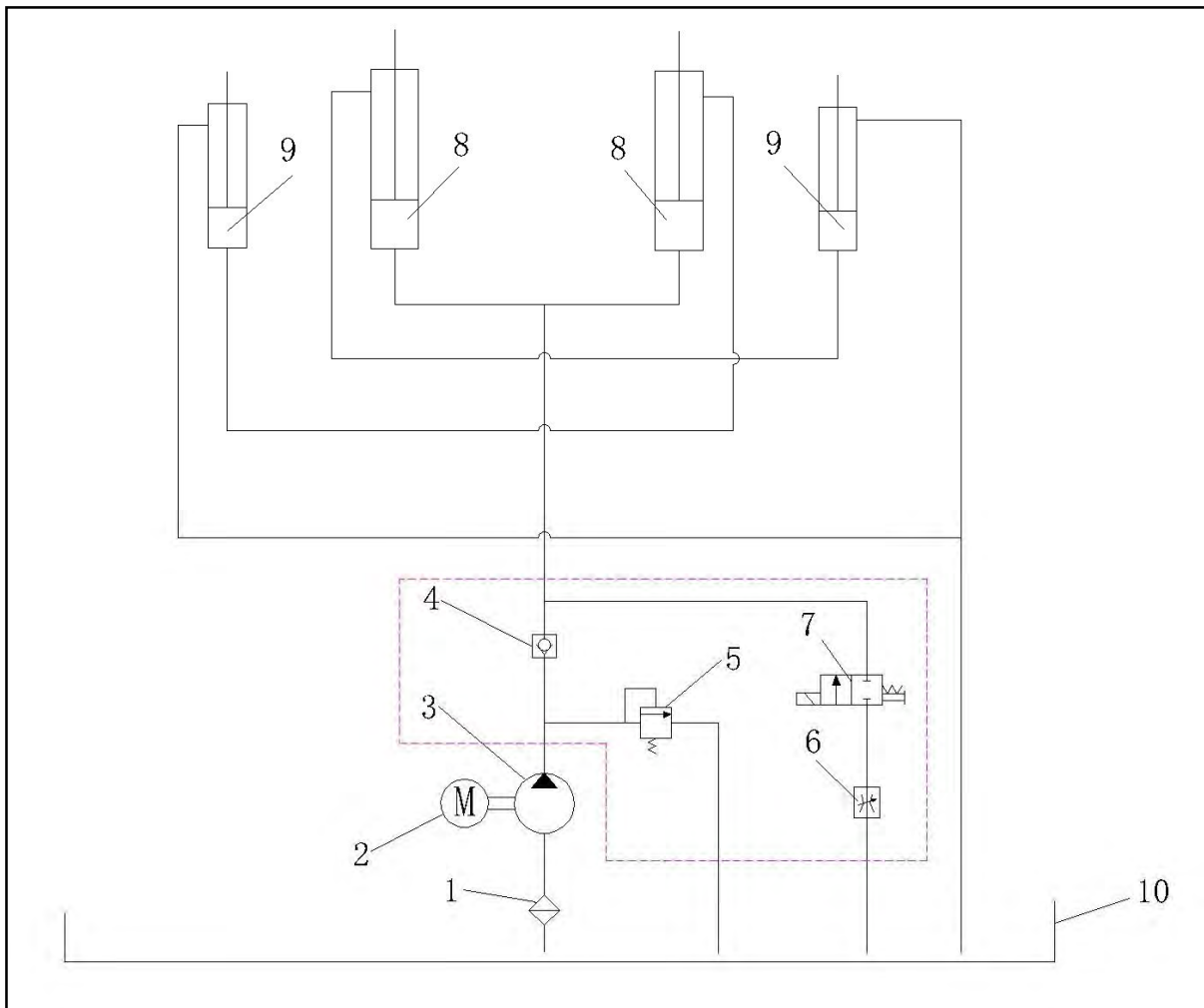

Picture 25

1. filter
2. pump motor
3. gear pump
4. check valve
5. overflowing valve
6. flow control valve
7. descent valve
8. main cylinder
9. sub cylinder
10. oil tank

Hose connection diagram

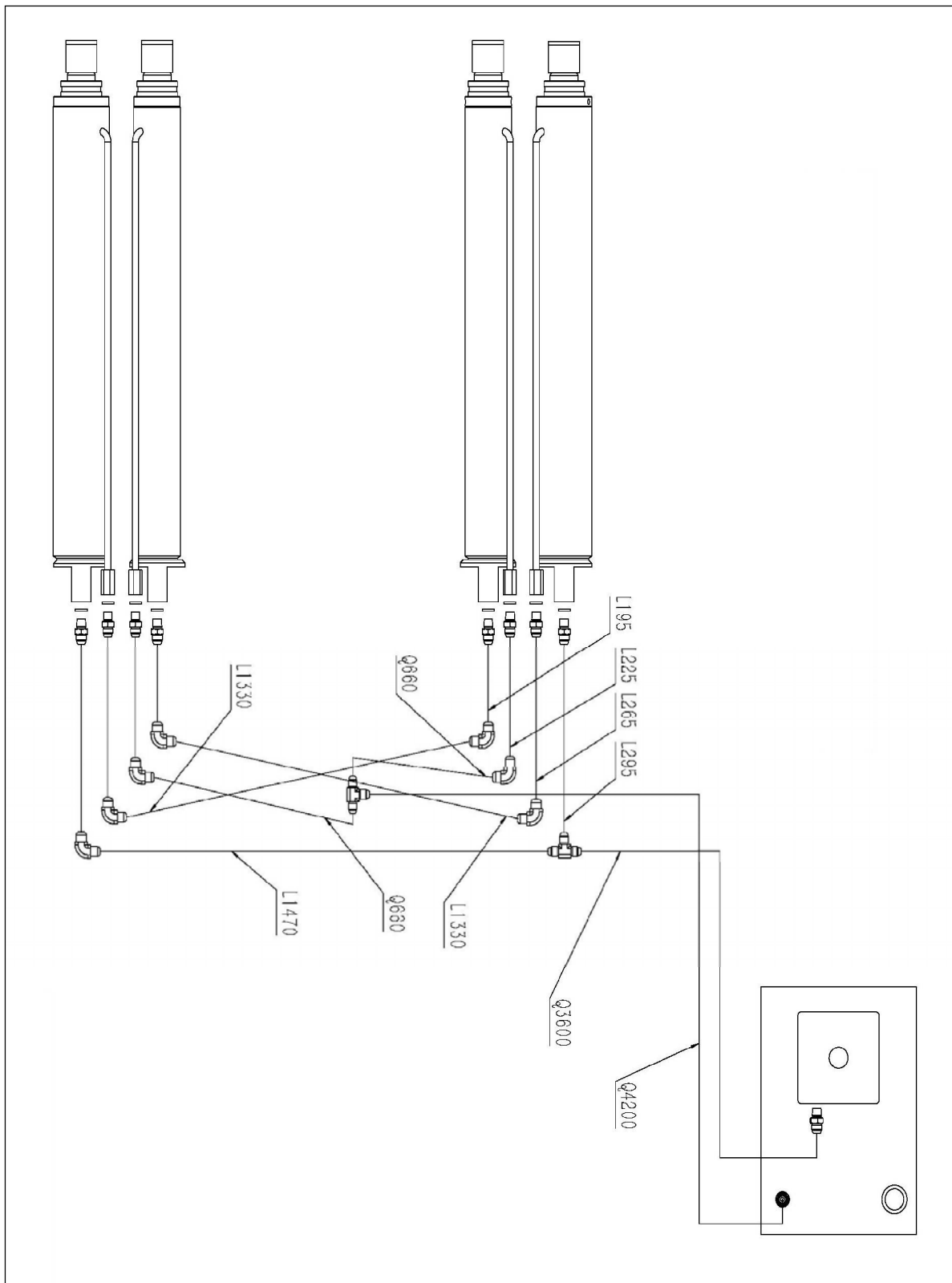

Picture 26

Explosion diagram 1

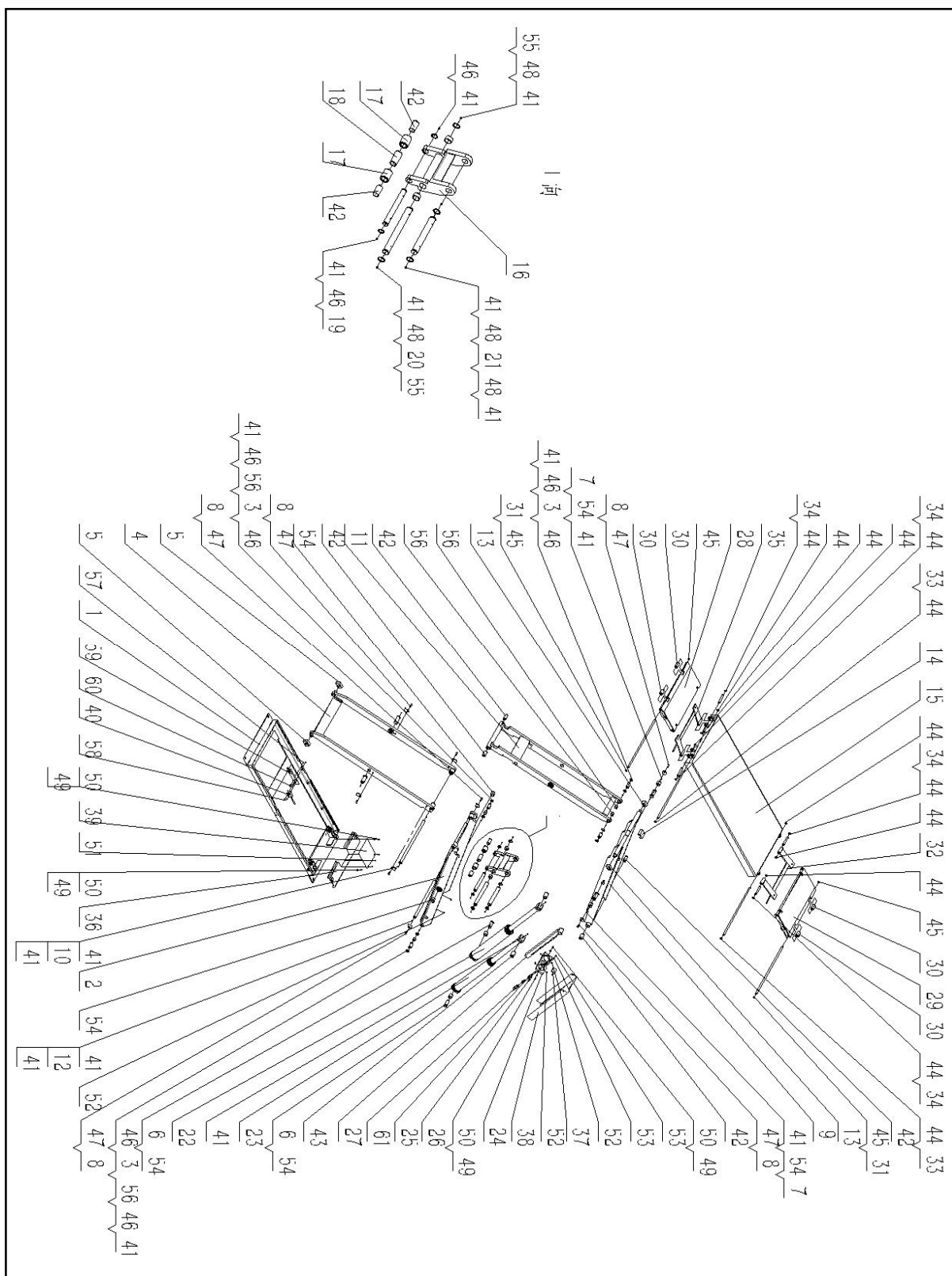

Picture 27

**Explosion diagram 2**

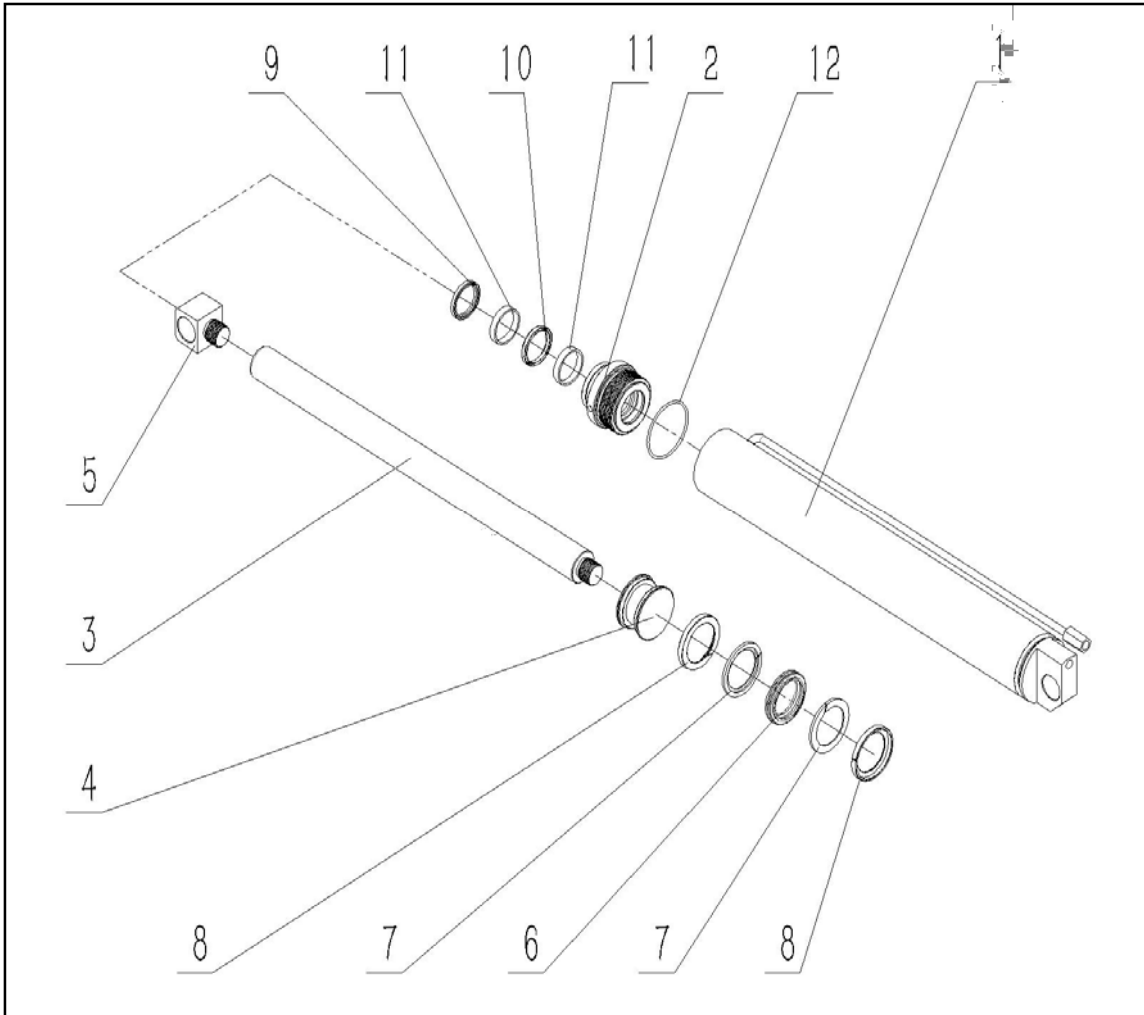

**Picture 28 main cylinder**

**Explosion diagram 3**

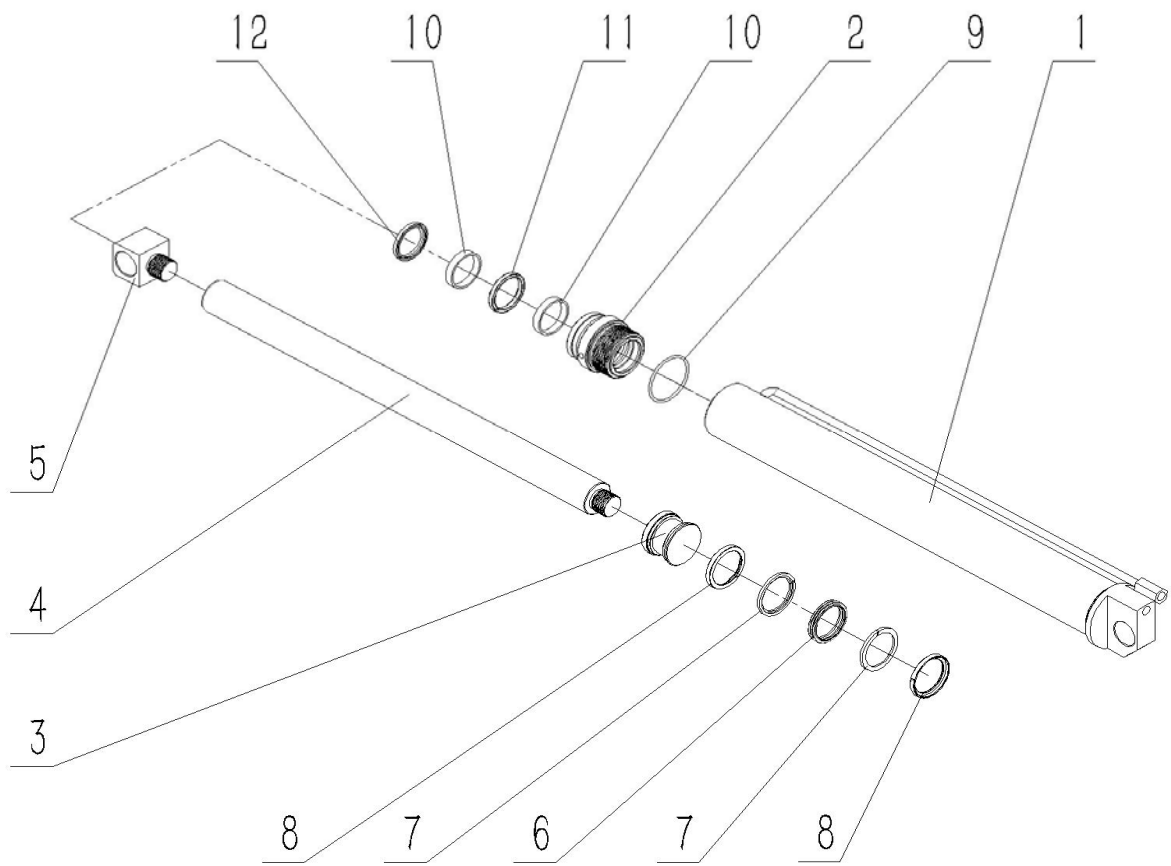

Picture 29 sub cylinder

## Small scissor lift exploded view list

serial number	Description	Code number	Quantity	Price/unit	Remark
1	Base		2		
2	Inner lower arm		2		
3	Support ear shaft on the base		8		
4	Outer lower arm		2		
5	Lower outer arm slider		4		
6	Lower inner arm oil cylinder support ear shaft		4		
7	Support arm middle shaft		8		
8	Support arm shaft plate		16		
9	Upper outer support arm		2		
10	Upper outer arm connecting shaft		2		
11	Upper inner support arm		2		
12	Inner upper arm connecting shaft		2		
13	Upper outer support arm slider		4		
14	Upper outer support arm middle slider		2		
15	Upper cover		2		
16	Assist arm		2		
17	Assist arm walking wheel		4		
18	Assist arm walking wheel spacer		2		
19	Assist arm lower shaft		2		
20	Assist arm central shaft		2		
21	Piston pole ring shaft		2		
22	Main cylinder		2		
23	Sub cylinder		2		
24	Oil cylinder fixing bracket		2		
25	Cylinder seat bolt		2		
26	Lock block fixing seat		2		
27	Lock bar		2		
28	Approach bridge(R)		2		
29	Approach bridge(L)		2		
30	Approach bridge pulley		8		
31	Approach bridge walking shaft		4		
32	Approach bridge lock bracket (L)		2		
33	Approach bridge axle		4		
34	Approach bridge lock shaft		8		
35	Approach bridge lock bracket (R)		2		
36	Base oil pipe buckle groove		2		
37	Lock block		2		
38	Oil cylinder guard plate		2		
39	Base oil pipe buckle groove rubber		2		
40	Travel switch		2		
41	Push-fit type grease nipples 6	JBT7940.4	40		

42	Oil-less axletree	2550	12		
43	Oil-less axletree	3050	4		
44	Snap ring φ16		24		
45	Snap ring φ12		8		
46	Snap ring φ25		20		
47	Socket cap screw M8×25	GB/T 70.1-2008	16		
48	Snap ring φ30		8		
49	Plain washer 6	GB/T 97.1-2002	8		
50	Socket cap screw M6×10	GB/T 70.1-2008	8		
51	Pan head screw with cross recess M5×6	GB/T 818-2016	6		
52	Hexagon socket set screw with conical point M8×10	GB / T 78-2007	12		
53	Socket cap screw M5×25	GB/T 70.1-2008	4		
54	Oil-less axletree	3030	12		
55	Oil-less axletree	3020	4		
56	Oil-less axletree	2520	8		
57	Prevailing torque type hexagon nuts(with non-metallic insert), style 1 M5	GB/T 6182-2010	4		
58	Socket cap screw M5×16	GB/T 70.1-2008	2		
59	Travel switch rack		2		
60	Socket cap screw M5×20	GB/T 70.1-2008	4		
61	Cylinder		2		

### Main cylinder explosion list

1	Cylinder 75		2		
2	Cylinder cover 75		2		
3	Piston rod 45		2		
4	Piston 75		2		
5	Piston pole ring		2		
6	Combined sealing rubber ring	KGD75×55	2		
7	Combined sealing Retaining Ring	KGD75×55	4		
8	Combined sealing Guide ring	KGD75×55	4		
9	Sealing ring	DH33-25-5-6	2		
10	Sealing ring	UN55-45-6	2		
11	Guide ring	50-45-9.5	4		
12	O-ring	d75×3.1	2		

### Sub cylinder explosion list

1	Cylinder 60		2		
2	Cylinder cover 60		2		
3	Piston 60		2		
4	Piston rod 45		2		
5	Piston pole ring		2		
6	Combined sealing rubber ring	KGD60×48	2		
7	Combined sealing Retaining Ring	KGD60×48	4		

8	Combined sealing Guide ring	KGD60×48	4		
9	O-ring	D60×3.1	2		
10	Guide ring	50-45-9.5	4		
11	Sealing ring	UN55-45-6	2		
12	Sealing ring	DH33-25-5-6	2		

**Circuit diagram:**

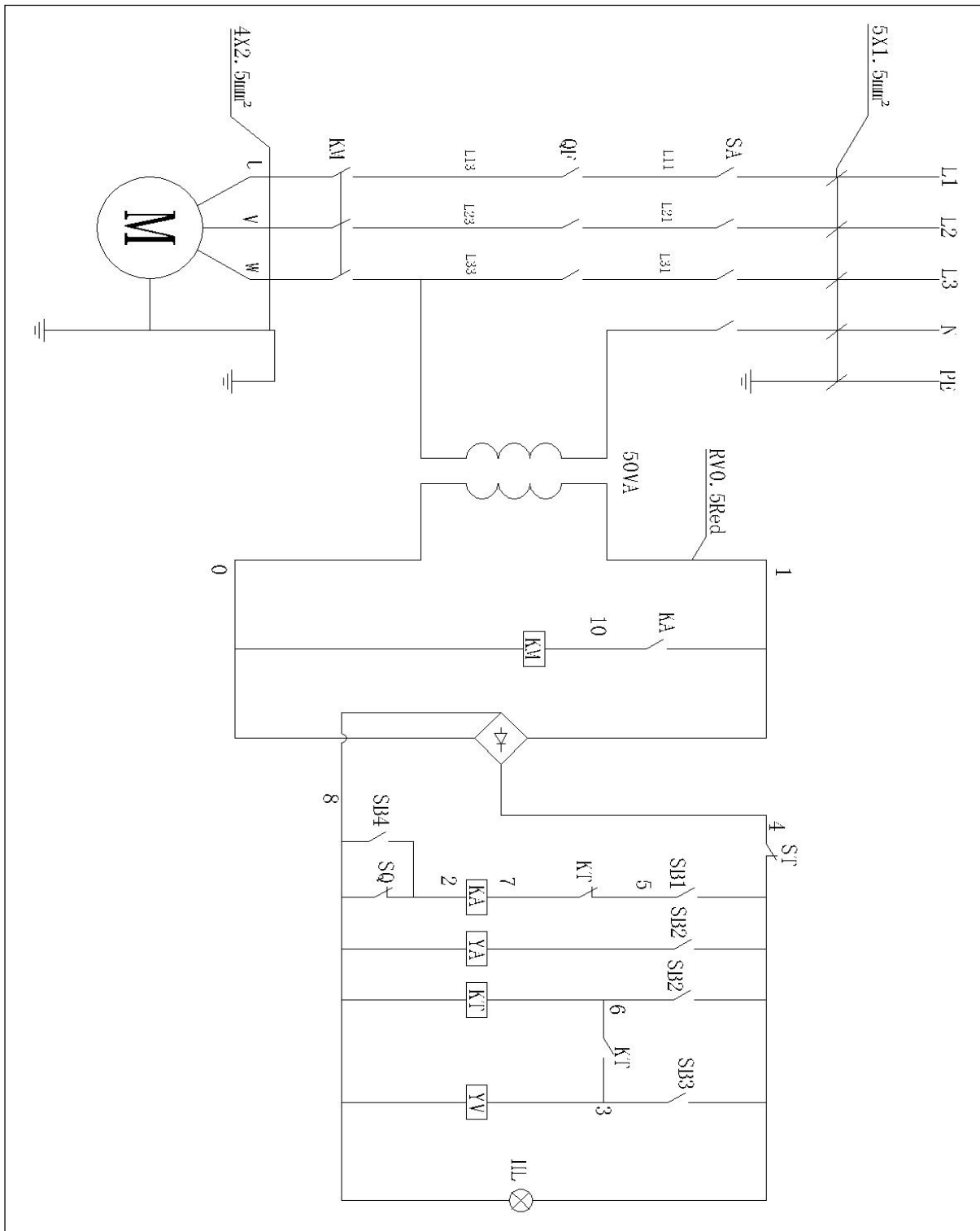

Picture 30

<b>ELECTRICAL COMPONENTS LIST</b>				
item	code	name	model	qty
1	SA	Air Switch		1
2	QF	Mains switch		1
3	KM	Contactora		1
4	ST	Emergency switch		1
5	M	Pump motor		1
6	HL	Power lamp		1
7	KT	Time relay		1
8	KA	Auxiliary relay		1
9	YV	Electromagnetic valve for descent		1
10	SB1	Up switch		1
11	SB2	Down switch		1
12	SB3	Lock switch		1
13	SB4	Leveling switch		1
14	SQ	Limit switch of main platform		1
15	YA	Solenoid air valve of main platform		1