



## Four-Post Lift KT-4H950



### **TWO LOCKS, DOUBLE PROTECTION**

Our four post lift has a double - lock protection. Even if the rope breaks, it can be locked automaticly and won't fall down.

**READ THIS ENTIRE MANUAL BEFORE INSTALLATION & OPERATION BEGINS.**

Product/Item Code	Four post lift
Brand	
Model	
Colour	
Voltage	
PO No.	
MADE IN CHINA	



This information is required when calling for parts or warranty issues.

## PRODUCT WARRANTY

Our comprehensive product warranty means more than a commitment to you; it's also a commitment to the value of your new KATOOL lift. For full warranty details and to register your new lift contact your nearest KATOOL dealer or visit:

**[www.katoolautoequip.com](http://www.katoolautoequip.com)**

We offer a limited one-year (12 months) warranty on all parts and against all product defects, free of charge to our customers, **on all equipment**.

\* Including but not limited to: Cylinders, power units, motors, displays, electronics, etc. Vehicle lifts will include an additional three-year (36 months) warranty on all lift **structural components only**.

Warranty claim for all products must fall within above period in order to qualify for limited warranty.

**Warranty is non-transferable, must have original order number, and purchased from our company or a registered vendor.** Replacement Parts will be provided at no cost to the customer and will include free shipping.

All warranty claims submitted to KATOOL are subject to approval by the warranty vice department and may be approved or denied at the full discretion of these departments. Photos and/or videos of original defects may be requested. Customers should not disassemble any piece of equipment before proof of original problem/issue has been determined.

**What is NOT covered under this warranty:**

- a. Any failure that results from Purchaser's abuse, neglect or failure to operate, maintain or service product in accordance with instructions provided in the owner's manual(s) supplied.
- b. Any damage caused by overloading lift beyond rated capacity.
- c. Items or service normally required to maintain the product, i.e. lubricants, oil, etc.
- d. Items considered general wear parts such as rubber pads, lifting cables, etc. unless wear or failure is a direct result of manufacturer defect due to material and/or workmanship.
- e. Any component damaged in shipment or any failure caused by installing or operating lift under conditions not in accordance with installation and operation guidelines or damaged by contact with tools or surroundings.
- f. Motor or pump failure caused by rain, excessive humidity, corrosive environments or other contaminants
- g. Rusted components due to improper maintenance or corrosive environments.
- h. Cosmetic defects that do not interfere with product functionality.
- i. Damage due to incorrect voltage or improper wiring.
- j. Any incidental, indirect, or consequential loss, damage or expense that may result from any defect, failure or malfunction of KATOOL Inc. product.
- k. Any equipment outside of the policy will not be covered and buyer will be responsible for purchasing replacement parts at full cost and shipping charges will apply.
- l. Labor is not included in warranty.

## INSTALLER / OPERATOR PLEASE READ AND FULLY UNDERSTAND.

### BY PROCEEDING YOU AGREE TO THE FOLLOWING:

- I have visually inspected the site where the lift is to be installed and verified the concrete to be in good condition and free of cracks or other defects.
- I Understand that installing a lift on cracked or defective concrete could cause lift failure resulting in personal injury or death.
- I understand that a level floor is required for proper installation and level lifting.
- I understand that I am responsible if my floor is of questionable slope and that I will be responsible for all charges related to pouring a new level concrete slab if required and any charges.
- I assume full responsibility for the concrete floor and condition thereof, now or later, where the above equipment model(s) are to be installed.
- Failure to follow danger, warning, and caution instructions may lead to serious personal injury or death to operator or bystander or damage to property.
- I understand that KATOOL lifts are designed to be installed in indoor locations only. Failure to follow installation instructions may lead to serious personal injury or death to operator or bystander or damage to property or lift.



Failure to follow danger, warning, and caution instructions may lead to serious personal injury

or death to operator or bystander or damage to property.



Please read entire manual prior to installation. Do not operate this machine until you read and understand all the dangers, warnings and cautions in this manual.

## INSTALLER / OPERATOR PROTECTIVE EQUIPMENT

Personal protective equipment helps makes installation and operation safe; however, it does not take the place of safe operating practices. Always wear durable work clothing during any installation and/or service activity. Shop aprons or shop coats may also be worn, however loose-fitting clothing should be avoided. Tight fitting leather gloves are recommended to protect technician hands when handling parts. Sturdy leather work shoes with steel toes and oil-resistant soles should be used by all service personnel to help prevent injury during typical installation and operation activities.

Eye protection is essential during installation and operation activities. Safety glasses with side shields, goggles, or face shields are acceptable. Everyday eyeglasses only have impact resistant lenses; they are not safety glasses.

Back belts provide support during lifting activities and are also helpful in providing worker protection. Consideration should also be given to the use of hearing protection if service activity is performed in an enclosed area, or if noise levels are high.

## IMPORTANT SAFETY INSTRUCTIONS

*Read these safety instructions entirely.*

### IMPORTANT NOTICE

Do not attempt to install this lift if you have never been trained on basic automotive lift installation procedures.

Never attempt to lift components without proper lifting tools such as forklift or cranes.

Stay clear of any moving parts that can fall and cause injury.

Read and understand all instructions and all safety warnings before operating lift.

The equipment can only be operated by qualified personnel trained to use this equipment. Misuse of the machine for other purpose or modifying any components of the equipment without receiving the permission from the manufacturer may result in direct or indirect damage to the equipment.

Due to the many variations in procedures, techniques, tools, and parts for changing tires as well as the skill and training of the individual performing the work, the manufacturer cannot anticipate any or all warnings necessary for the safe operation of the equipment. It is the technician's responsibility to be knowledgeable in the safe and acceptable means of changing tires on the wheels that are being serviced. Never endanger your safety, the safety of others in the work area or the equipment or vehicle being serviced.

1. Eye and face protection recommendations:  
Protective eye and face equipment is required while using this equipment due to

potential of injury." O.S.H.A. 1910.133(a) Protective goggles, safety glasses, or a face shield must be provided by the owner and worn by the operator of the equipment. Care should be taken to see that all eye and face safety precautions are followed by the operator. ALWAYS WEAR SAFETY GLASSES. Everyday glasses only have impact resistant lenses; they are not safety glasses.

2. Read and understand this manual before operating. Abuse and misuse will shorten the functional life.
3. NEVER remove safety related components from the lift. Do not use lift if safety related components are missing or damaged.
4. STAY ALERT. Use common sense and watch what you are doing. Remember, SAFETY FIRST.
5. Only trained operators should operate this lift. All non-trained personnel should be kept away from the work area. Never let non-trained personnel come in contact with, or operate lift.
6. DO NOT override self-closing lift controls.
7. ALWAYS make sure the safeties are engaged before attempting to work on or near a vehicle.

8. **WARNING! RISK OF EXPLOSION.** This equipment has internal arcing or sparking parts which should not be exposed to flammable vapors. This machine should not be located in a recessed area or below floor level.



9. Check for damaged parts. Check for alignment of moving parts, breakage of parts or any condition that may affect operation of lift. Do not use lift if any component is broken or damaged.
10. Clear area if vehicle is in danger of falling.
11. KATOOL requires all operators to read and be familiar with ANSI/ALI ALIS Safety Requirements for Installation and Service of Automotive Lifts.
12. Guard against electric shock. This lift must be grounded while in use to protect operator from electric shock. Never connect the green power cord wire to a live terminal. This is for ground only.
13. **DANGER!** To reduce the risk of electric shock, do not use on wet surfaces or expose to rain. The Power Unit used on this lift contains high voltage. Disconnect power at the receptacle or at the circuit.
14. Care must be taken as burns can occur from touching hot parts.
15. Do not operate equipment with a damaged cord or if the equipment has been dropped or damaged until it has been examined and repaired by a qualified serviceman.
16. Do not let cord hang over edge of table, bench, or counter or come in contact with hot manifolds or moving fan blades.



17. If an extension cord is necessary, a cord with a current rating equal to or more than that of the equipment should be used. Cords rated for less current than the equipment may overheat. Care should be taken to arrange the cord so that it will not be tripped over or pulled.
18. Always unplug equipment from electrical outlet when not in use. Never use the cord to pull the plug from the outlet. Grasp plug and pull to disconnect.
19. Let equipment cool completely before putting away. Loop cord loosely around equipment when storing.
20. Keep guards and safety features in place and in working order.
21. Wear proper clothing. Safety toe, non-slip footwear and protective hair covering to contain hair is recommended. Do not wear jewelry, loose clothing, neckties, or gloves when operating the balancer.
22. Keep work area clean and well lighted. Cluttered and/or dark areas invite accidents.
23. Avoid dangerous environments. Do not use power tools or electrical equipment in a damp or wet environment, or expose them to rain.
24. Use only manufacturer's recommended accessories. Improper accessories may result in personal injury or property damage.

25. Repair or replace any part that is damaged or worn and that may cause unsafe balancer operation.
26. Do not operate damaged equipment until it has been examined and repaired by a qualified service technician.
27. To reduce the risk of fire, do not operate equipment in the vicinity of open containers or flammable liquids (gasoline).
28. Switch off the breaker switch before performing any electrical repairs. Secure plug so that it cannot be accidentally plugged-in during service. or mark circuit breaker switch so that it cannot be accidentally switched-on during service.
29. Adequate ventilation should be provided when working on or operating internal combustion engines.
30. Keep hair, loose clothing, fingers, and all parts of body away from moving parts.
31. Use equipment only as described in this manual.
32. Use only manufacturer's recommended attachments and accessories.
33. The equipment should be installed on the stable surface and not on a wooden pallet.
34. Do not install the equipment in a place with high temperature or moisture, near the heating system, water tap, air-humidifier or chimney.
35. Avoid contact with lots of dust, ammonia, alcohol, thinner or spraying binder.
36. People who are not operating the machines should be kept away during normal operation.
37. Pay special attention to the warning labels on the machine.
38. Do not touch or approach the moving parts by hand during operation.
39. Do not remove the safety device or prevent it from working properly.

**SAVE AND FOLLOW THE ABOVE INSTRUCTIONS**

## Operator Protective Equipment:

Personal protective equipment helps make tire servicing safer. However, equipment does not take the place of safe operating practices. Always wear durable work clothing during tire service activity. Loose fitting clothing should be avoided. Tight fitting leather gloves are recommended to protect operator's hands when handling worn tires and wheels. Sturdy leather work shoes with steel toes and oil-resistant soles should be used by tire service personnel to help prevent injury in typical shop activities. Eye protection is essential during tire service activity. Safety glasses with side shields, goggles, or face shields are acceptable. Back belts provide support during lifting activities and are also helpful in providing operator protection. Consideration should also be given to the use of hearing protection if tire service activity is performed in an enclosed area, or if noise levels are high.

## Definitions of Hazard Levels

Identify the hazard levels used in this manual with the following definitions and signal words:

### DANGER

Watch for this symbol:



It Means: Immediate hazards, which will result in severe personal injury or death.

### WARNING

Watch for this symbol:



It Means: Hazards or unsafe practices, which could result in severe personal injury or death.

### CAUTION

Watch for this symbol:



It Means: Hazards or unsafe practices, which may result in minor personal injury or product or property damage.

## BE ALERT

Watch for this symbol! It means BE ALERT! Your safety, or the safety of others, is involved!



## Safety Notices and Decals



Failure to follow danger, warning, and caution instructions may lead to serious personal injury or death to operator or bystander or damage to property. Do not operate this machine until you read and understand all the dangers, warnings and cautions in this manual. For additional copies of either, or further information, contact:

## Standard Safety Devices



**Keep hair, loose clothing, fingers and all parts of body away from moving parts.**

- Press STOP key for stopping the wheel under emergency conditions.

 **WARNING**

**RISK OF EXPLOSION**

This equipment has internal arcing or sparking parts which should not be exposed to flammable vapors. Do not locate in a recessed area or below floor level.

**THIS EQUIPMENT MUST BE EARTH-GROUNDED**

The earth-ground connector built into the power cord provides protection to reduce the risk of electrical shock.

 **AVERTISSEMENT**

**RISQUE D'EXPLOSION**

Cet équipement possède des pièces internes, pouvant lancer des arcs ou jeter des étincelles, et qui ne devraient pas être exposées à des vapeurs inflammables. Ne situez pas l'équipement dans des endroits encastrés ou en-dessous du niveau du plancher.

**CET ÉQUIPEMENT DOIT ÊTRE MIS À LA TERRE**

Le raccord de mise à la terre incorporé dans le cordon de puissance fournit une protection afin de réduire le risque d'électrocution.

 **CAUTION**

Do not use below garage floor or grade level.

Disconnect power before servicing this equipment.

To prevent electrical shock, do not remove cover. No user servicable parts inside. Refer servicing to qualified service personnel.

 **ATTENTION**

N'utilisez pas en-dessous du plancher du garage ou du palier.

Débranchez le cordon de puissance avant de faire l'entretien de cet équipement.

Afin de vous protéger contre l'électrocution, n'enlevez pas le couvercle. Aucune pièce interne ne nécessite d'entretien par l'utilisateur. Référez l'entretien à un personnel de service qualifié.

8113927 05

# INTRODUCTION

Congratulations on the purchase of the KATOOL 4 Post Lift. This vehicle lift is designed for ease of operation, safe handling of vehicles. This equipment will provide many years of trouble-free operation requiring minimum maintenance and care. Please read this manual thoroughly before operating the unit. Instructions on use, maintenance and operational of the lift are covered in this manual.

1. Carefully remove the crating and packing materials. CAUTION! Use care when cutting steel banding material as items may become loose and fall, causing injury.

2. Check the voltage, phase, and proper amperage requirements for the motor shown on the motor plate. Wiring MUST be performed by a certified electrician only.

## **Owner's Responsibility**

To maintain the lift and user safety, the responsibility of the owner is to read and follow these instructions:

Follow all installation and operation instructions.

- Make sure installation conforms to all applicable Local, State, and Federal Codes, Rules, and Regulations; such as State and Federal OSHA Regulations and Electrical Codes.
- Carefully check the lift for correct initial function.
- Read and follow the safety instructions. Keep them readily available for machine operators.
- Make certain all operators are properly trained, know how to safely and correctly operate the unit, and are properly supervised.
- Allow unit operation only with all parts in place and operating safely.
- Carefully inspect the unit on a regular basis and perform all maintenance as required.
- Service and maintain the unit only with authorized or approved replacement parts.
- Keep all instructions permanently with the unit and all decals on the unit clean and visible.

## **Receiving:**

The shipment should be thoroughly inspected as soon as it is received. The signed bill of lading is acknowledgement by the carrier of receipt in good condition of shipment covered by your invoice. If any of the goods called for on this bill of lading are shorted or damaged, do not accept them until the carrier makes a notation on the freight bill of the shorted or damaged goods. Do this for your own protection.

NOTIFY THE CARRIER AT ONCE if any hidden loss or damage is discovered after receipt and request the carrier to make an inspection. If the carrier will not do so, prepare a signed statement to the effect that you have notified the carrier (on a specific date) and that the carrier has failed to comply with your request.

IT IS DIFFICULT TO COLLECT FOR LOSS OR DAMAGE AFTER YOU HAVE GIVEN THE CARRIER A CLEAR RECEIPT. File your claim with the carrier promptly. Support your claim with copies of the bill of lading, freight bill,

invoice, and photographs, if available. Our willingness to assist in helping you process your claim does not make KATOOL responsible for collection of claims or replacement of lost or damaged materials.



Any other use is to be considered incorrect and unreasonable. The manufacture will not be responsible for any damage caused from misuse of this Tire Changer. Any use other than that specified in this manual is inappropriate, incorrect, and unreasonable.

**KEEP THIS MANUAL NEAR THE MACHINE FOR FUTURE REFERENCE**

## Table of Contents

PRODUCT WARRANTY	2
Installer / Operator Instructions	4
Operator Protective Equipment	4
Important Safety Instructions	5
Definitions of Hazard Levels	8
Introduction	10
Table of content	12
1.0 Product Specifications:	13
1.1 Parts Inventory & Description:	15
1.2 Key Machine Components	16
1.2.1 Model Description	17
1.2.2 Purpose	17
1.2.3 Functions and Features	17
1.2.4 Technical Specifications	18
1.2.5 Basic parameters of the equipment	18
1.2.6 Environmental Requirements	18
2.0 Lift Structure	19
2.0.1 Main Structural Principles	20
3.0 Operation Description	21
3.0.1 Precautions for vehicle repair work	21
3.0.2 Preparation before operation	21
3.0.3 Inspection before operation	21
4.0 Lifting and Lowering the Vehicle:	22
4.0.1 Lifting the Vehicle	22
4.0.2 Lowering the Vehicle	25
4.0.3 Manual Emergency Lowering	25
5.0 Hydraulic and Electrical System of the Equipment	26
5.0.1 Hydraulic System of the Lift:	26
5.0.2 The working principle of the hydraulic system	27
5.0.3 Electrical System of the Lift	28
5.0.4 The electrical working principle is as follows	28
6.0 Frequently Asked Questions (FAQ):	29
7.0 Repair and Maintenance	30
8.0 Maintenance of Hydraulic System	33
9.0 Storage and Scrap	33
10.0 Lift Set Up Instructions	34
10.0.1 Mechanical Installation	35
10.0.2 Electrical Installation	62
10.0.3 Lift Adjustment	63
10.0.4 Bleeding a 2-post lift (Without Bleeder Holes)	65
11.0 Safety Instructions	66
12.0 Sales and Tech Support Contact info	69



**Failure to follow the instructions and safety precautions in this manual can result in serious injury or death. Make sure all other operators also read this manual. Keep the manual near the product for future reference. *By proceeding with setup and operation, you agree that you fully understand the proper use of this product and assume full responsibility of product use.***

## 1.0 Product Specifications

### KT-4H950 Four Post Heavy Duty Vehicle Lift 8,500 lbs.

**\*Concrete thickness must be at least 3.93" (100 MM) with a 3000 PSI rating. Failure to install this lift on the proper concrete could result in serious injury or death! It is the customer's responsibility to verify concrete thickness and strength before purchase and installation.**

- 9500lbs lifting capacity.
- CE Approved and Certified. It has adopted the 115% dynamic loading capacity standard and was 150% static loading capacity tested.
- Single Point Manual Safety Lock Release
- Four mechanical locking devices, a secondary lock system acts as a slack-cable device to engage in the unlikely event of cable failure.
- Power side column can be installed at both sides, front or rear.
- Non-skid diamond platforms and adjustable safety lock ladders.
- Comes with a caster kit for moving the lift around.
- Comes with three drip trays and a jack tray.
- High-quality hydraulic system with 110V/60HZ/1PH or 220V/60HZ/1PH (Optional)

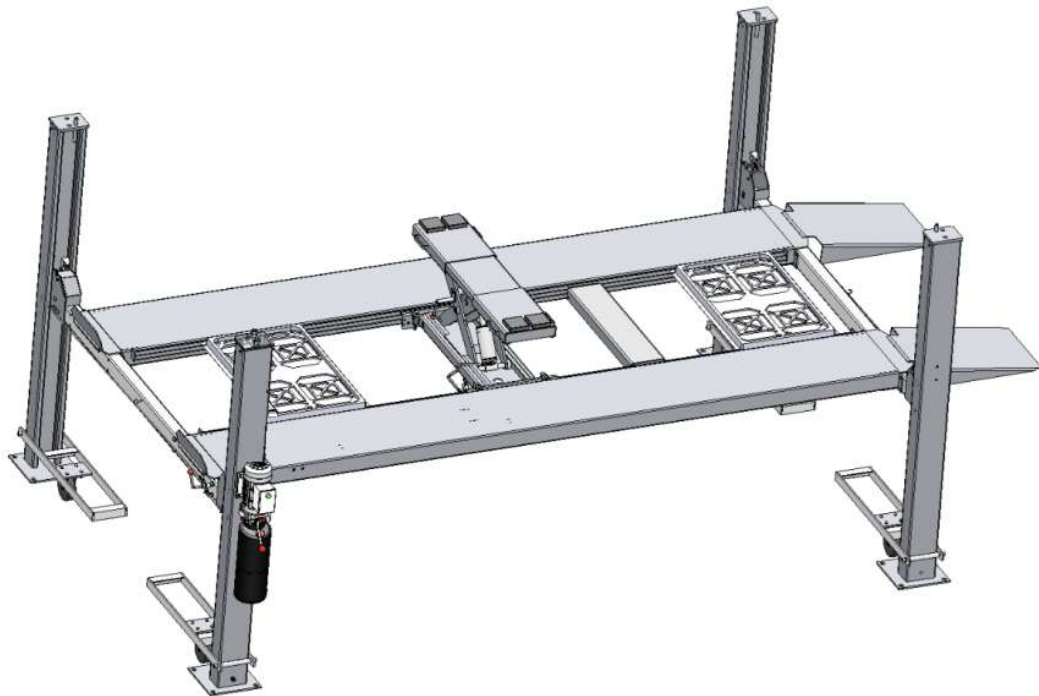

Figure 1

Lifting Capacity	9500 lbs. (4309 KG)
Max. Lifting Height	84.5" / 2146 mm
Lifting Time	50s Up / 40s Down
Height of Posts	97" / 2463 mm
Width Overall	113" / 2870 mm
Length Overall	189" / 4801 mm (with ramps)
Inside Columns	99.5" / 2525.5 mm
Min. Runway Height	4.76" / 121mm
Motor	110VAC/60HZ/1PH
Net Weight	2095lbs / 950KG

## 1.1 Parts Inventory & Description

Be sure to take a complete inventory of parts prior to beginning installation.

Description	QTY
Parts Box and Other Small Items	1
Pump Station Base/Pump Mounting Bracket	1
Power Unit /Pump Station	1
Wheel Stop Plate	2
Hydraulic Cylinder	1
Safety Ladder	4
Unlocking Pull Rod (Long)/Locking Rod (Long)	2
Unlocking Pull Rod (Short)/Locking Rod (Short)	2
Unlocking Link Rod/Locking Rod T-Handle	2
Unlocking Wrench/Safety Release Handle	1
Unlocking Shaft Tube/Safety Lock Connecting Rod	1
Main Platform/Powerside Runway	1
Secondary Platform/Offside Runway	1
Post/Columns	4
Hydraulic Hose	2
Drive-on Platform/Vehicle Ramps	2
Front Crossbeam/Crossbeam A	1
Rear Crossbeam/Crossbeam B	1
Caster Assemblies	4
Unlocking Rod Support Bracket/Safety Lock Connecting Rod Brackets	2
Side Bracket for Drive-on Platform/Offside runway flange bracket	1
Post Top Cap/Column Top Plate	4
Hydraulic Hose Crossover Fitting	1
Air Hose Crossover Fitting	1
Pump Direction Adjustment Plate	1
Expansion Bolts	16
Oil Drip Tray	1

Figure 2

## 1.2 Key Machine Components:

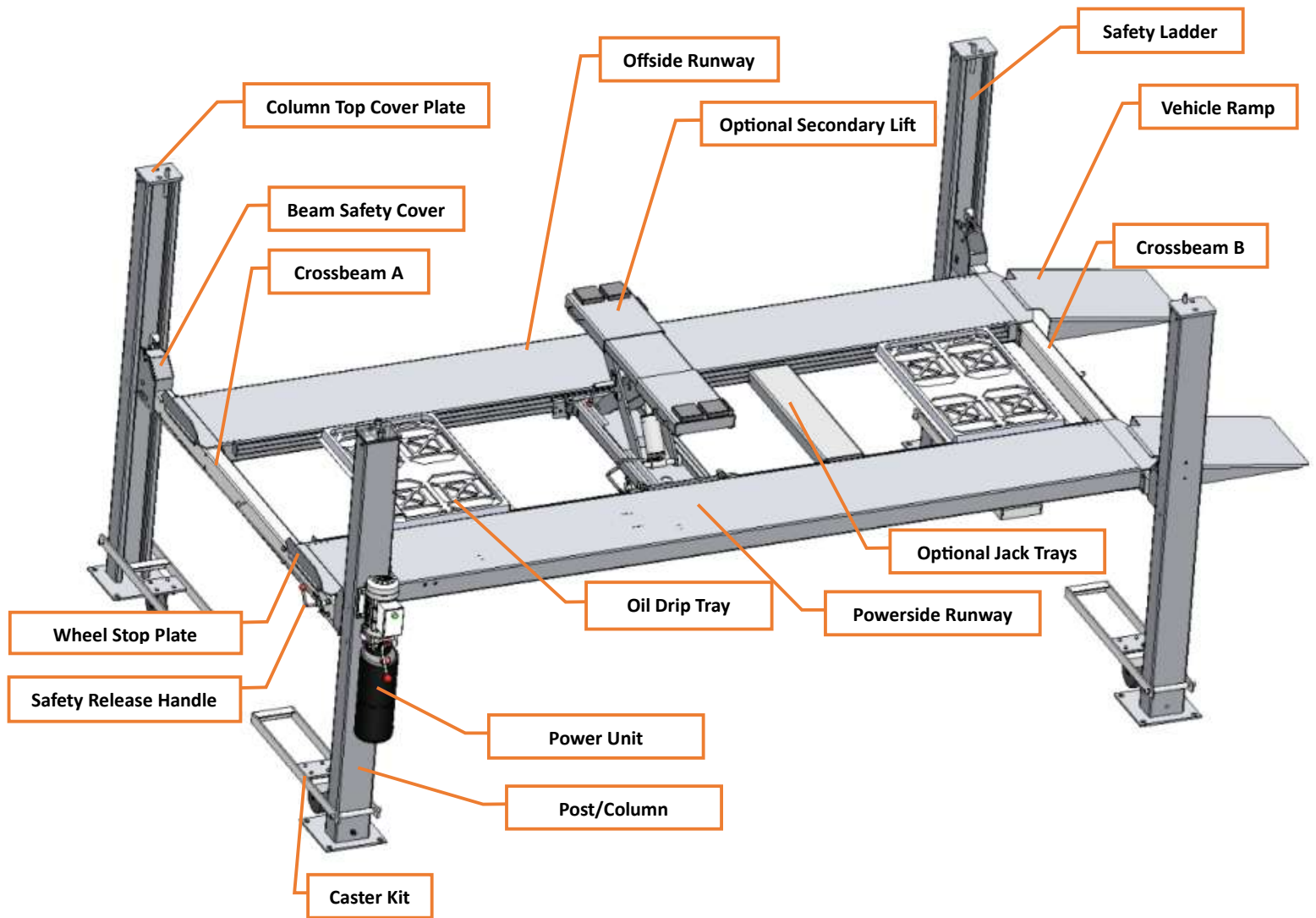

**KT-4H950**

Figure 3

## Outline:

### 1.2.1 Model Description:

Model	Description
KT-4H950 4-Post Lift with Crossbeam	Four Post Heavy Duty Vehicle Lift 9,500 lbs. (Fig.1)

### 1.2.2 Purpose

This machine is designed to lift various small and medium-sized vehicles with total weight 8500lbs in garage and workshop.

### 1.2.3 Functions and Features

- All cables are fully concealed for elegant appearance.
- The equipment is designed based on international standards, meeting the needs of automotive garages and workshops.
- Top limit switch, effectively protects the vehicle from overhead damage.
- Manual lowering of the vehicle is achieved with a safe and simple operation system.
- A quad cable system provides a synchronous, balanced force to the four carriages to effectively prevent the vehicle from tilting.

## 1.2.4 Technical Specifications

**Noise:** Working noise:  $\leq 75\text{dB(A)}$

**Power unit:** Electrical parameters of the machine: Motor (optional)

**Voltage:** According to client's requirement

**Single phase:** 110V/60Hz 2.2kW, 220V/50Hz 2.2 kW, 200V/60Hz 2.2 kW

**Amperage Requirement:** 30 Amp

## 1.2.5 Basic parameters of the equipment:

Model	Rated Load (lbs.)	Lifting Height (in/mm)	Raising Time (sec)	Decent Time (sec)	Net Weight (lbs./kg)	Width between Columns (in/mm)	Machine Width (in/mm)	Machine Height (in/mm)
KT-4H950	9500 lbs. (3850 kg)	84.5" (2146 mm)	$\leq 50\text{s}$	$\geq 20\text{s}$	2095 lbs. (950 KG)	99.5" (2525.5 mm)	113" (2870 mm)	97" (2463 mm)

## 1.2.6 Environmental Requirements:

**Working temperature:**  $-50^{\circ}\text{C} \sim 40^{\circ}\text{C}$

**Relative humidity:** 80% @  $30^{\circ}\text{C}$

**Transport/storage temperature:**  $-5^{\circ}\text{C} \sim +400^{\circ}\text{C}$

**Height above sea level:** 2000m max

## 2.0 Lift Structure

Lift structures (narrow and wide layout) are shown as below:

Model	Description
KT-4H950 4-Post Lift with Crossbeam	Four Post Heavy Duty Vehicle Lift 9,500 lbs. (Fig.1)

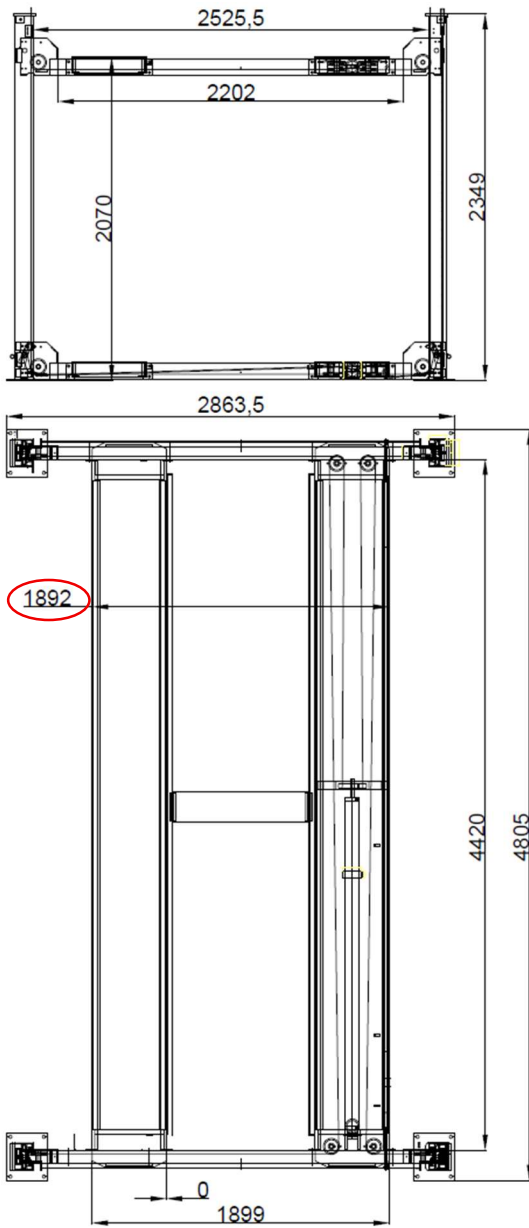

Narrow Runway Layout

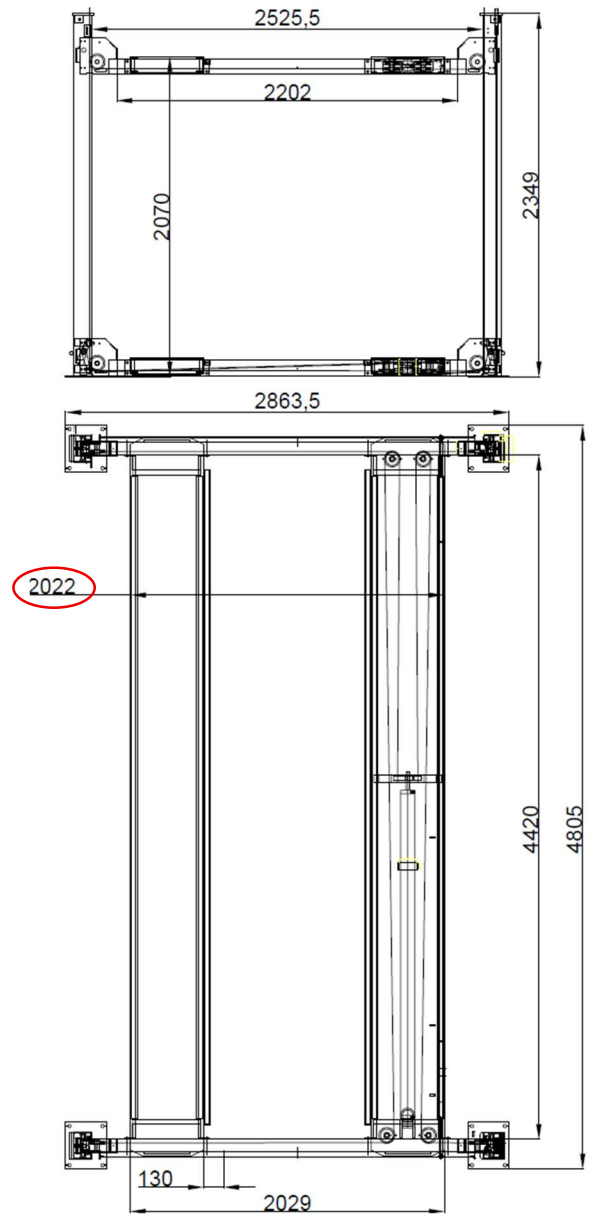

Wide Runway layout

Figure 4 - KT-4H950 4-Post Lift with Crossbeams in 2 runway spacing layouts



**Note:**

- 1) ***This lift can be setup with two runway layouts driven by the width of vehicles being serviced (see Figure 4).***
  - a. ***Narrow layout with runway spacing of 1892 mm.***
  - b. ***Wide layout with runway spacing of 2022 mm.***
- 2) ***Narrow layout will allow you to install Drip trays and Jack trays***
- 3) ***There are no Drip trays and Jack trays available for wide runway layout.***

### **2.0.1 Main Structural Principles:**

**Lifting mechanism:** The front two columns and the rear two columns are connected with Crossbeams A and B. When hydraulic oil is pushed from power unit into the lower chamber of main cylinder, the piston rod moves to drive the upward movement of the Crossbeams via the cable and the pulley mechanism which raises the platforms to lift the vehicle.

**Balance mechanism:** In order to keep machine balanced during lifting and lowering process; the two Crossbeams are interconnected and forced to move synchronously by four cables. If the crossbeam A and crossbeam B are not at the same level, adjust the end nut of cables and pull steel cables tight to make A and B beams leveled.

**Manual safety locking system:** There are Safety Ladders installed on the four columns. During the lifting of the carriage, the safety locking plate goes up against the toothed bar plate by spring tension. When the carriage stops, the safety locking plate opens and then engages in the toothed bar slot to lock the carriage in position and prevents it from falling down. When the lowering operation is required, raise the carriage upward a little to loosen the safety locking plate from the Safety Ladder. Turn safety lock handle clockwise and press down on the lowering handle. This will disengage the safety lock to allow lowering of the carriage.

**Safety lock scope:** Safety lock mechanism is effective between 450 mm and 2250 mm high above the ground.

## 3.0 Operation Description

### 3.0.1 Precautions for vehicle repair work

- Carefully read all warning labels.
- The hydraulic valves have been factory calibrated, and the user can't make self-adjustment, otherwise the user will be responsible all consequences.
- Some specifications in the instruction manual are subjected to change without notice depending on production needs.

### 3.0.2 Preparation before operation

- Lubricate contact surface of the carriage with general-purpose lithium grease (GB7324-87).
- All sliding surface should be coated evenly from the top to bottom.
- Check the oil level. Fill hydraulic oil N32 or N46 to the oil reservoir of the power unit if the oil level is low.

### 3.0.3 Inspection before operation

- Check to see if the motor power is installed properly.
- Check to see if all the connection bolts are fastened.

## **WARNING**

***Note: Don't operate the lift with damaged cables or damaged and missing parts. The lift should only be operated after it is repaired and inspected by a qualified professional repair technician.***

## 4.0 Lifting and Lowering the Vehicle:

### Importance of Choosing a Lift with Adequate Capacity

Selecting a lift with a capacity that exceeds the vehicle's weight requirements is advisable. This accounts for variables like vehicle modifications, additional equipment, or unexpected weight distributions. Many manufacturers recommend not exceeding 75% of a lift's rated capacity to maintain safety margins.

### Safe Operating Practices

- Adhere to Weight Limits: Never exceed the lift's total capacity.
- Proper Vehicle Positioning: Ensure that the vehicle is completely stopped at the platform baffles.
- Regular Maintenance: Follow the manufacturer's maintenance schedule and conduct routine inspections to identify potential issues.

By understanding and respecting the weight capacities and operational guidelines of four-post lifts, automotive shops can ensure safer working conditions and prolonged lifespan of their equipment.

### 4.0.1 Lifting the Vehicle

- Keep work area clean, especially under the platforms(runways).
- Do not operate the lift in cluttered work area.
- Lower the carriage to the lowest position by pressing the lowering handle at the power unit.
- The lift will stop as soon as the platform is at its lowest position.
- Move the vehicle to the location between crossbeam A and crossbeam B.
- Drive the vehicle onto the lift's runways, using a spotter or mirror to center it so that its weight is balanced.
- Make sure to park the vehicle evenly between the front and rear crossbeams as shown below.

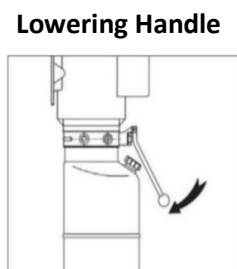

**⚠ CAUTION**

- Once the car is in position, **apply the parking brake** and **place wheel chocks** on at least one wheel on both sides.

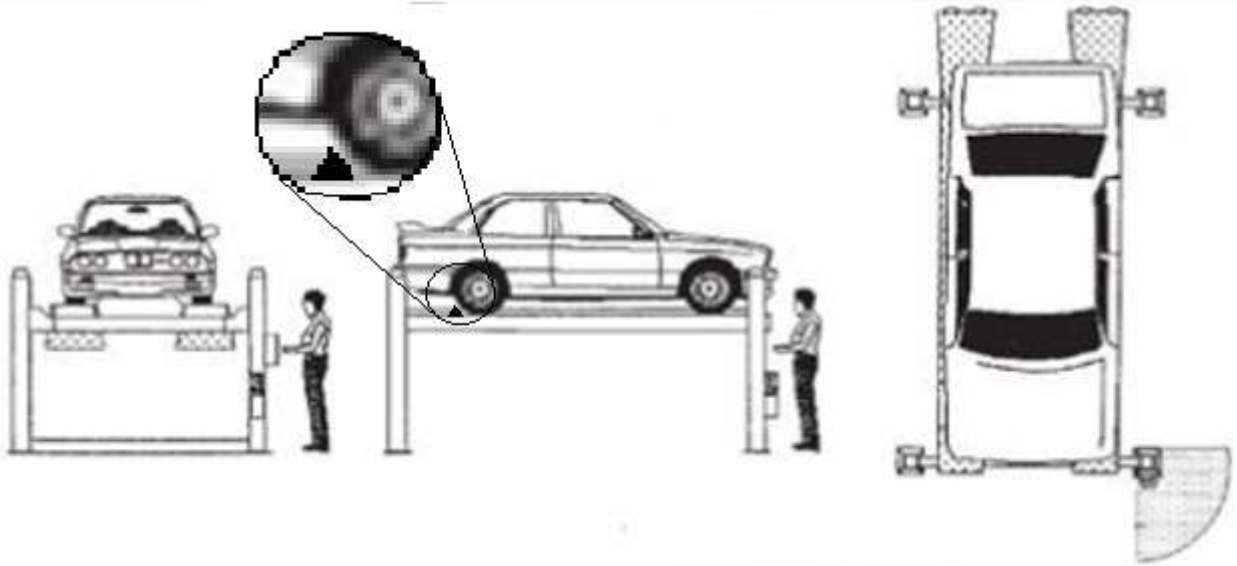

- Press the UP button on the electric control box to slowly lift the vehicle to the required height.
- Lift will stop once the UP button is released or upward travel limit is reached.
- Press the Lowering Handle to lower the vehicle to engage the safety lock of the Safety Ladder in all four columns.
- Engage the safety lock by turning the safety release handle counter clockwise. Now the vehicle is ready to be repaired.

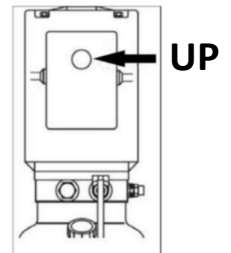

- **⚠ WARNING** ***Never unlatch the safety release handle when the lift is under load.***
- Do not allow unauthorized persons to stay under the raised vehicle.
- Avoid rocking of vehicle.
- Keep the lift free of tools, parts, etc.
- Secure the vehicle to the platform by using lashing straps when removing or installing heavy components.

## **CAUTION**

### **Note:**

- **Before operation, the safety locking devices must be Inspected.**
  - 4) Inspect the steel cable for broken strands.**
  - 5) Inspect the platforms for any deformation.**
- **Before lifting the vehicle, check all the hydraulic hose and fittings for oil leakage. In case of leakage, please don't use the lift. Remove the fitting with leakage. Re-install the fitting with new sealant and check if oil leakage still exists. Replace with a new fitting if the oil leak does not stop.**
- **After the vehicle is lifted, when adding or removing any major heavy object, use a secondary lift mechanism to maintain the balance of the vehicle.**

## **WARNING**

- **Always engage the safety lock before going under the vehicle.**
- **Never allow anyone to go under the lift when raising or lowering the vehicle. Read the safety procedures in the manual.**
- **During raising and lowering cycles: Closely watch the vehicle and the lift, do not allow anyone to stay in the lift area and make sure the vehicle doors are closed.**
- **Always make sure safety latches in all four columns clear the rack at same time when pulling down the release handle by adjusting the cable.**

## 4.0.2 Lowering the Vehicle

- Clean the work area before lowering the vehicle.
- Stay clear of the vehicle before lowering the vehicle.
- First press the UP button to rise the vehicle a little, then turn the safety release handle clockwise to disengage the safety lock.

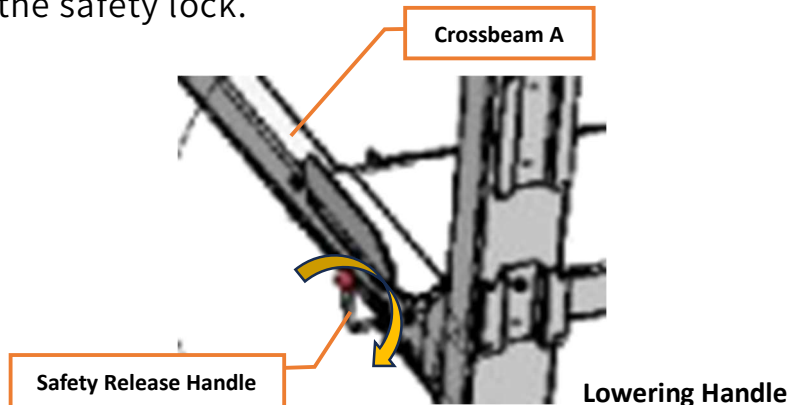

- Push down the lowering handle to lower the vehicle.
- Lower the vehicle till the platform reaches its lowest position.
- Then release the lowering handle.

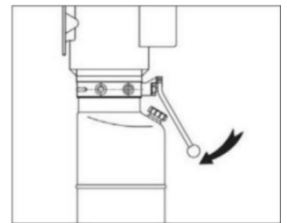

## 4.0.3 Manual Emergency Lowering

- In case of no electric power or power unit failure, lower the loaded vehicle manually to its initial position as follows:
- Lockout tag out the power switch.
- If the mechanical safeties are engaged, raise the lift a little by using a hydraulic jack or the emergency hand pump (optional), then turn the safety release handle clockwise to release the safety lock.
- Press the lowering handle to lower the vehicle.



### Note:

- ***In case of loss of function, you must switch off the power.***

## 5.0 Hydraulic and Electrical System of the Equipment:

### 5.0.1 Hydraulic System of the Lift

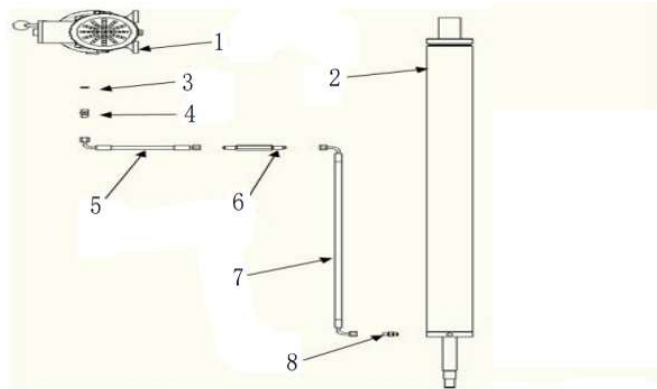

Figure 7a - Main cylinder hydraulic connection exploded layout

Item	Description	Qty
1	Pump station (manual unloading)	1
2	Main cylinder	1
3	Combined washer 14	1
4	Hydraulic tubing joint	1
5	Pump station hydraulic tubing	1
6	Hydraulic tubing joint	1
7	Hydraulic cylinder tubing	1
8	Hydraulic tubing joint	1

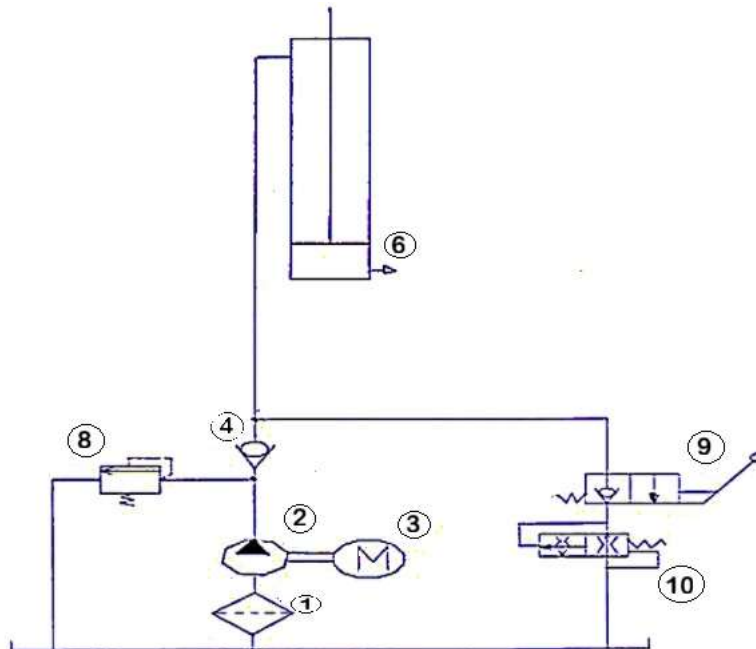

Figure 5

## **5.0.2 The working principle of the hydraulic system is as follows:**

- As shown in above figure 5, when the start button is pressed, the pump motor is started, driving the oil pump, sucking the hydraulic oil from the oil tank into the Master cylinder (2), forcing the piston rod to move. At this time, the safety valve is closed.
- (The safety valve controls the pressure in the system for the rated load, but when the pressure in the system exceeds the limit, the safety valve will overflow automatically to protect the hydraulic system).
- Release the start button to stop the oil supply and the lifting will stop. For lowering; first push the start button to start the pump motor to raise vehicle a little, turn the safety release handle clockwise to release the safety lock mechanism, then press the lowering handle simultaneously while holding the safety release handle rotated clockwise. The valve is actuated, the hydraulic oil flows back and the lift starts lowering.

### 5.0.3 Electrical System of the Lift:

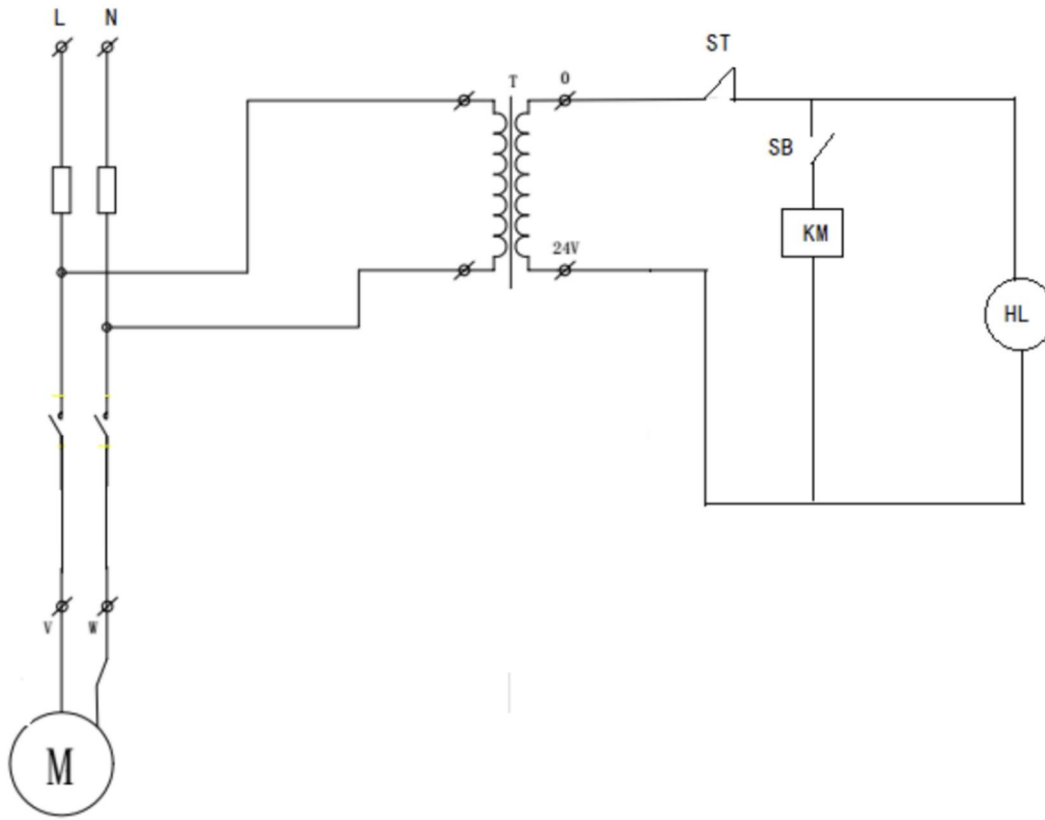

Figure 6

### 5.0.4 The electrical working principle is as follows:

When the start button (SB) is pressed, the contactor (KM) will be powered; motor (M) is energized to drive the gear pump supplying oil to push the carriage upward.

When the start button is released, the contactor (KM) opens, the motor (M) will lose the power, to stop the raising of the carriage. As for the Crossbeam lift, if the vehicle is lifted up to the top and contacts the limit switch on the top beam, the contactor (KM) will open, then the motor (M) will lose the power, to stop the carriage.

## 6.0 Frequently Asked Questions (FAQ):

Symptom	Reason	Solution
Motor not operation	<ul style="list-style-type: none"> <li>• Check the circuit breaker or thermal relay for tripping</li> <li>• Check the voltage to the motor</li> <li>• Check the electrical wiring</li> <li>• Limit switch is failed</li> <li>• Motor wire is burnt</li> </ul>	<ul style="list-style-type: none"> <li>• Close the switch of circuit breaker or press the blue reset key of thermal relay</li> <li>• Supply correct voltage for motor</li> <li>• Correctly wiring as electrical system diagram</li> <li>• Replace the limit switch</li> <li>• Replace the motor</li> </ul>
Motor is running, but the lift can't be raised.	<ul style="list-style-type: none"> <li>• Motor rotation reversed</li> <li>• Lowering valve body open.</li> <li>• Hydraulic pump sucks the air</li> <li>• Suction tube is separate from the hydraulic pump.</li> <li>• Low oil level</li> </ul>	<ul style="list-style-type: none"> <li>• Change the motor rotating direction through changing wire connection.</li> <li>• Repair or replace the lowering valve Body</li> <li>• Fasten all the suction pipe fittings</li> <li>• Replace the suction tube</li> <li>• Add the oil into the oil tank</li> </ul>
Motor is running, the lift can be raised without load, but the vehicle can't be raised	<ul style="list-style-type: none"> <li>• Motor is running under low voltage</li> <li>• Impurities inside the lowering valve body</li> <li>• Regulation pressure of safety valve is incorrect.</li> <li>• Lift is overloaded</li> </ul>	<ul style="list-style-type: none"> <li>• Supply correct voltage to the motor</li> <li>• Remove impurities from the lowering valve body.</li> <li>• Adjust the safety valve</li> <li>• Check the weight of the vehicle</li> </ul>
The lift is lowering slowly without pressing the lowering handle	<ul style="list-style-type: none"> <li>• Impurities on the lowering valve body.</li> <li>• External oil leakage</li> </ul>	<ul style="list-style-type: none"> <li>• Clean the solenoid valve body</li> <li>• Repair the external leakage</li> </ul>
The lifting speed is slow or oil flows out of the oil fill cap	<ul style="list-style-type: none"> <li>• Air and oil are mixed</li> <li>• Air and oil suction are mixed</li> <li>• Oil return pipe is loosened</li> </ul>	<ul style="list-style-type: none"> <li>• Replace the hydraulic oil</li> <li>• Fasten all the suction pipe fittings</li> <li>• Re-install the oil return pipe</li> </ul>
The lift can't rise horizontally	<ul style="list-style-type: none"> <li>• Balance cable is not adjusted properly</li> <li>• The lift is installed on the slop floor</li> </ul>	<ul style="list-style-type: none"> <li>• Adjust the balance cable to the proper tension</li> <li>• Shimming the columns to level the lift (no more than 5mm), If exceeding 5mm, pour new concrete floor and make it leveled. Refer to installation description.</li> </ul>
Anchor Bolt is not fastened	<ul style="list-style-type: none"> <li>• Hole is drilled too big</li> <li>• Concrete floor thickness or fastening force is insufficient .</li> </ul>	<ul style="list-style-type: none"> <li>• Pour the fast curing concrete into the big hole and re-install the anchor Bolt , or use new drill to drill the hole for re-positioning the lift</li> <li>• Cut open the old concrete and make new concrete slab for the lift. Refer to installation description.</li> </ul>



*If the problems remain unsolved, call for technical support.*

## 7.0 Repair and Maintenance

### Cleaning:

- The lift should be cleaned with dry cloth frequently. Switch off the power before cleaning, to ensure safety.
- The working environment of this unit should be clean.
- Excessive dust in the working environment, will speed up the wear of the parts and shorten the service life of the lift.

### Every day:

- If the local voltage fluctuation exceeds 10%, a voltage regulator should be installed.
- Before the operation, carefully check the safety mechanism of the lift to ensure the electromagnet suction and release action is proper, and the safety plate is in good condition.
- When finding any abnormal situation, make sure to repair or replace the failed components immediately.
- Check to see if the steel cable connection is proper, and if the tension is at the optimum status.
- The four safety locks should always be synchronized into the square hole of the lock plate, and should be adjusted when there is no synchronization to ensure the safe operation of the machine.
- Check to see if the connection between hydraulic cylinder and carriage shows no damage, and make sure that the connecting nut between the steel chain and carriage is not lose or falling.
- Tighten all anchor bolts.
- Lubricate chains/cables.
- Check all the chain connectors, bolts and pins to ensure correct installation.
- Check all the hydraulic lines for wear or leaks.
- Check to see if the carriage and the inner side of the column are properly lubricated. Use high-quality heavy lubrication grease (Lithium based lubrication grease GB7324-87).

- If there is one of the following situations, the wire rope should be scrapped and a new wire rope should be installed:
  - When the whole rope strand breaks.
  - In the 80mm length range, the external broken wire more than 9 ropes or 350mm length more than 20 ropes.
  - When the outside diameter is reduced by more than 15%.
  - When the broken wire gathers in the same strand or in a very short range.
  - When the wire rope is severely corroded.
  - When the wire rope is twisted.

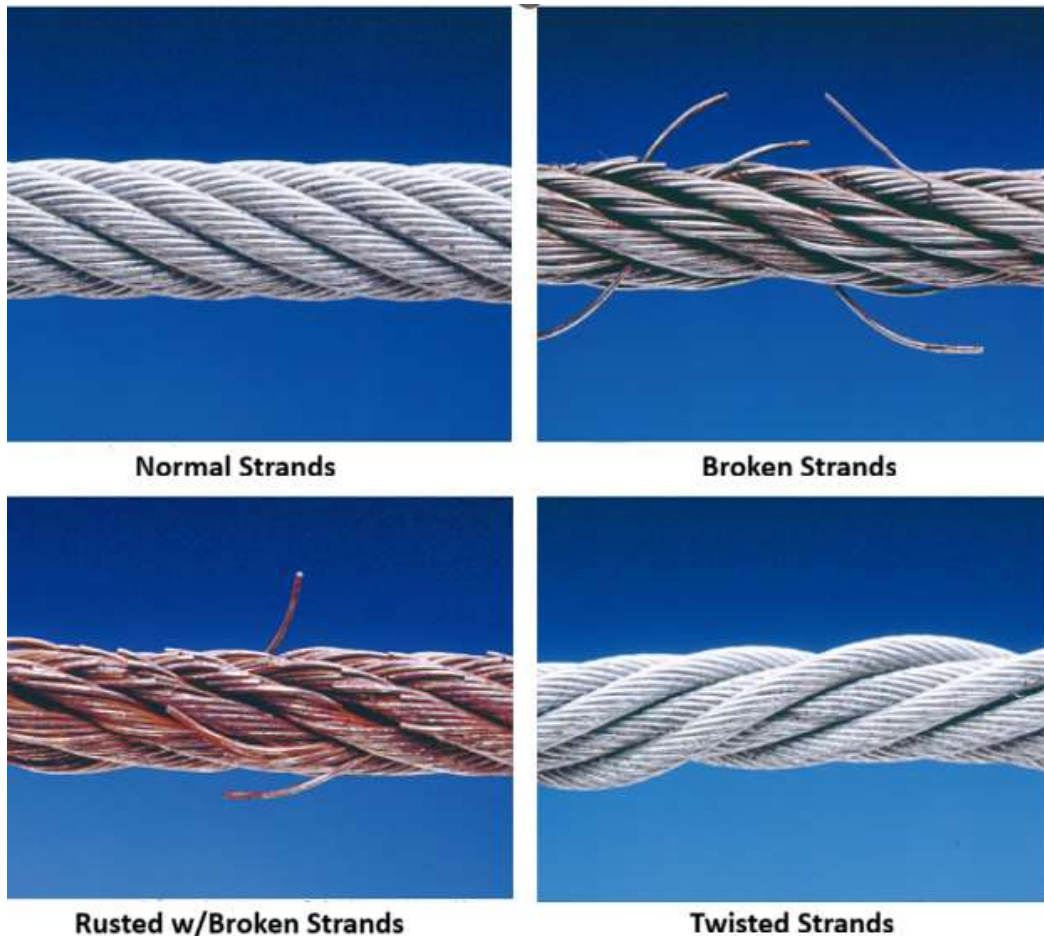

**⚠ WARNING**

**Note: All the anchor bolts should be tightened and secured completely. If any screw is loose, the lift cannot be used until the bolt is replaced or tightened.**

## Every six months:

- The oil filter in the oil tank should be cleaned every 3 months.
- Make sure to replace the hydraulic oil after 3 months of first-time use. After that the oil should be replaced every 6 months.
- When changing the oil clean the oil tank and filter with gasoline.
- Check all the movable parts for possible wear, interference or damage.
- Check the lubrication of all the pulleys. If the pulley is dragging during the lifting and lowering operation, add appropriate lubricant to the wheel axle.
- When necessary, check and adjust the balancing tension to ensure a horizontal lift and lowering of the carriage.
- The length of the wire rope should be adjusted regularly to ensure that the platform is in the lowest position, and the 4 wire ropes are pulled tight.
- Always ensure that the columns are vertical and not tilted.



**Note: The inside walls of each column should be lubricated with lubricant, to minimize the roller friction and ensure smooth and even lifting.**

## **8.0 Maintenance of Hydraulic System:**

- Make sure to change the oil 6-months after initial use of the lift unit. When performing the 6-month service, make sure to clean the hydraulic oil tank.
- When used for the first time or after a long time (more than one month), N32 or N46 anti-wear hydraulic oil should be added before normal operation, and the oil level should be maintained.
- Later clean the hydraulic system once a year, and replace the oil.
- Replace the seal After this unit is put into operation for certain period of time.
- If an oil leakage is found, carefully look for the source of the leak; if the leakage is due to the worn seals, immediately replace the seals.

## **9.0 Storage and Scrap:**

### **9.0.1 Storage**

When the equipment requires long-time storage:

- Disconnect the power supply
- Lubricate all the parts requiring lubrication: mobile contact surface of the carriage, etc.
- Empty all the oil/liquid storage units
- Put the plastic cover over the equipment for dust protection.

### **9.0.2 Scrap**

When the equipment service life is expired and can no longer be used, disconnect the power supply, and properly dispose of as per relevant local regulations.

# 10.0 Lift Set Up Instructions

## IMPORTANT NOTICE

These instructions must be followed to ensure proper installation and operation of your lift. Failure to comply with these instructions can result in serious bodily harm and void product warranty. Manufacturer will assume no liability for loss or damage of any kind, expressed or implied resulting from improper installation or use of this product.

**PLEASE READ ENTIRE MANUAL PRIOR TO INSTALLATION**

### Selecting Site Notice

Before installing your new lift, check the following.

- LIFT LOCATION:** Always use architects plans when available. Check layout dimension against floor plan requirements making sure that adequate space is available.
- OVERHEAD OBSTRUCTIONS:** The area where the lift will be located should be free of overhead obstructions such as heaters, building supports, electrical lines etc.
- DEFECTIVE FLOOR:** Visually inspect the site where the lift is to be installed and check for cracked or defective concrete.



- OPERATING TEMPERATURE.** Operate lift only between temperatures of 41° -104° F.
- Lift is designed for **INDOOR INSTALLATION ONLY**. Outdoor use is prohibited.

### Floor Requirements



This lift must be installed on a solid level concrete floor with no more than 3-degrees of slope. Failure to do so could cause personal injury or death.



A level floor is suggested for proper use and installation and level lifting. If a floor is of questionable slope, consider a survey of the site and/or the possibility of pouring a new level concrete slab.



- DO NOT** install or use this lift on any asphalt surface or any surface other than concrete.
- DO NOT** install or use this lift on expansion seams or on cracked or defective concrete.
- DO NOT** install or use this lift on a second / elevated floor without first consulting building architect.

### CONCRETE SPECIFICATIONS

LIFT MODEL	CONCRETE REQUIREMENTS
11,000 Lb Models:	5.9" Min. Thickness 3,000 PSI
10,000 Lb Models:	5.9" Min. Thickness 3,000 PSI
10,000 Lb Models:	5.9" Min. Thickness 3,000 PSI



All models **MUST** be installed on 3,000 PSI concrete only, conforming to the minimum requirements shown above. New concrete must be adequately cured for 28 days.

**When removing the Lift from shipping angles, pay close attention as the Posts can slide and can cause injury. Prior to removing the Bolts, make sure the Posts are held securely by a Forklift, Shop Crane, or some other heavy lifting device.**

## 10.0.1 Mechanical installation

### Tools for Installation and Adjustment

To ensure proper installation and adjustment, please prepare the following tools:

Tool	Model
Leveling instrument	Carpentry type
Chalk line	Min 177.17" (4.5m)
Hammer	1.5kg
Medium crescent wrench	1.57" (40mm)
Open-end wrench set	0.43"-0.91" (11mm-23mm)
Ratchet socket set	
Flat Screw driver	5.91" (150mm)
Rotary hammer drill	0.75" (19mm)
Concrete drill-bit	ϕ 0.75" (19mm)

Tape Measure (7.5m)



Hammer



LevelBar



English Spanner(12")



Wrenchset: (12", 13", 14", 15", 17", 19", 24", 30")



Carpenter's Chalk



ScrewSets



Pliers



LockWrench



socket Head Wrench: (3", 5", 6", 8")



## Unpacking

- Disassemble the posts from the packing support bracket by removing the screws marked by arrows below.
- Remove the packing materials and inspect the lift for any sign of shipment damage. Check the packing list to see if the main parts and accessories are complete.
- Keep the packing materials away from the children to avoid injury; dispose off any packing materials in a safe and proper manner.
- Layout everything on the floor and inspect everything.

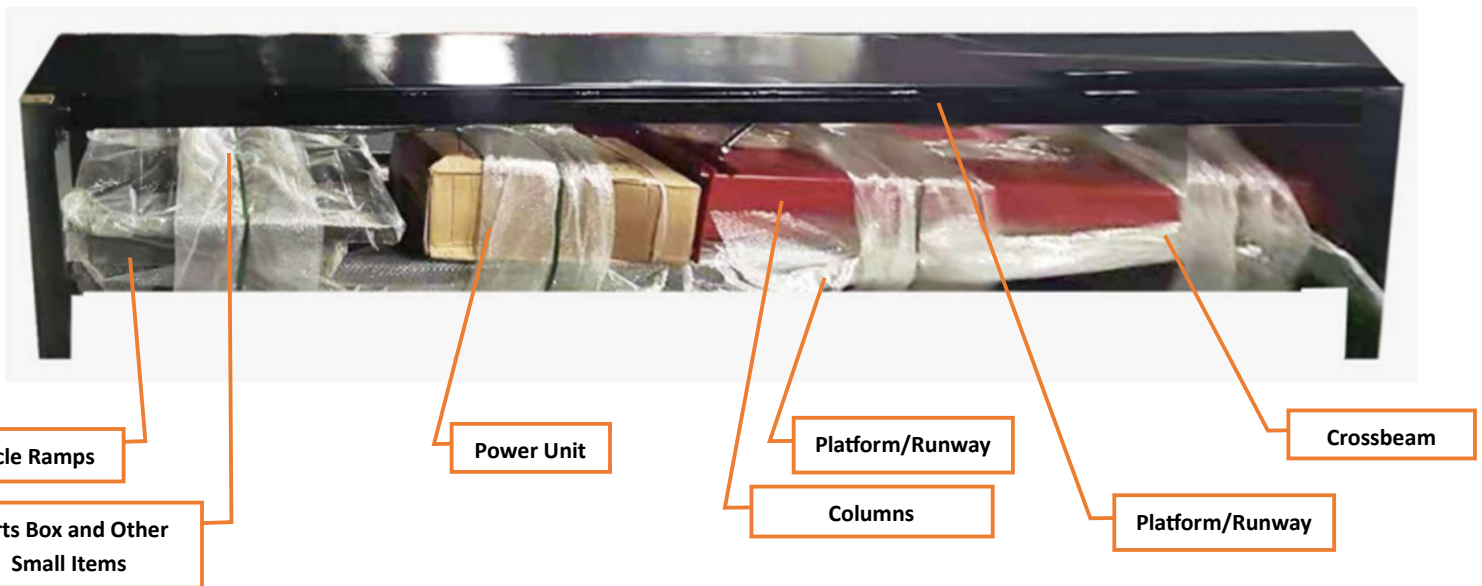

Figure 7



Figure 8

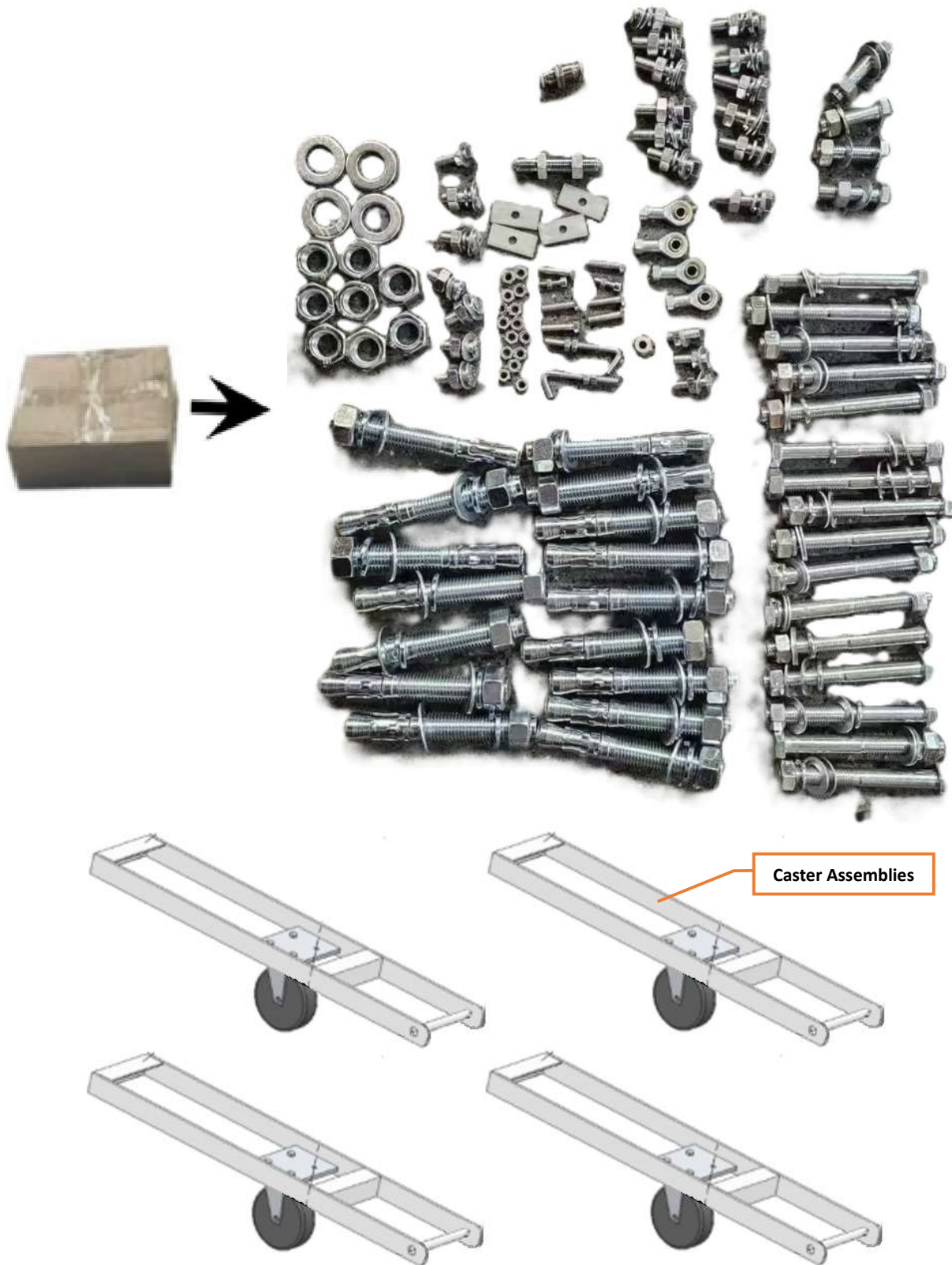

Figure 9 – Parts Box Items/Caster Assemblies

**Important notice:**



- Incorrect installation of the lift system can cause damage to the lift or personal injury.
- The manufacturer will not take any responsibilities for any damage caused due to incorrect installation and usage of this equipment, directly or indirectly.
- The correct installation location shall be flat horizontal floor to ensure a proper horizontal lift.
- A lift system installed on a slightly sloped floor can be levelled by proper shimming. Any large slope will affect the height of the lifting pad when at the bottom or the maximum lift height.
- If the floor is of questionable slope, consider a visual inspection, or pour a new horizontal concrete slab if possible.
- In short, the level of the lift relies on the level of the floor where it is installed.
- Do not install the lift on a grade that has a giant slope.

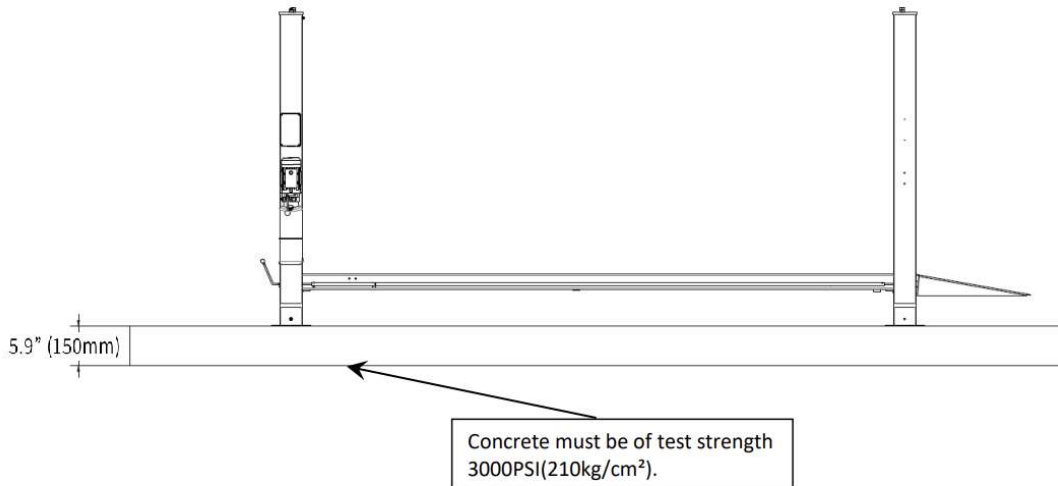

Figure 10 – Concrete Specification

**Installation site:**



Select installation site based on the following conditions:

- Lift can only be installed on concrete slab, which must have a minimum thickness of 5.9” (150mm) with a 3000 PSI rating or more and should be aged at least 7 days.
- Don’t install the lift on any asphalt surface or any surface other than concrete.
- The concrete slab should be reinforced using steel bar.
- The concrete slab must be level.
- Check for possible obstruction, e.g. low ceiling height, wireways, conduits, overhead pipeline, walkways, exits, etc.
- The front and back of the lift should be reserved with sufficient space to accommodate all the vehicles.
- Adequate space around the lift should be provided based on local fire and evacuation safety code.
- Don’t install the lift on the concrete with seams or cracks and defects.



- Make sure to get the post installation inspected and certified by an architect.
- Without the written approval of the architect, don’t install the lift on a second

floor or a floor with a basement.



- Overhead obstruction: The lift installation area can’t have any overhead obstruction, such as HVAC system, building support, electrical pipe, utility lines/conduits etc.
- When selecting the location for the lift make sure there is enough ceiling clearance.
- Concrete drilling test: The installation personnel can test the concrete strength by performing the concrete drilling test. If several lifts are installed at one place, it is preferred to complete a drilling test on each site.
- Power supply: Make sure to get a dedicated power line installed by a certified electrician

**Support Column Layout:**

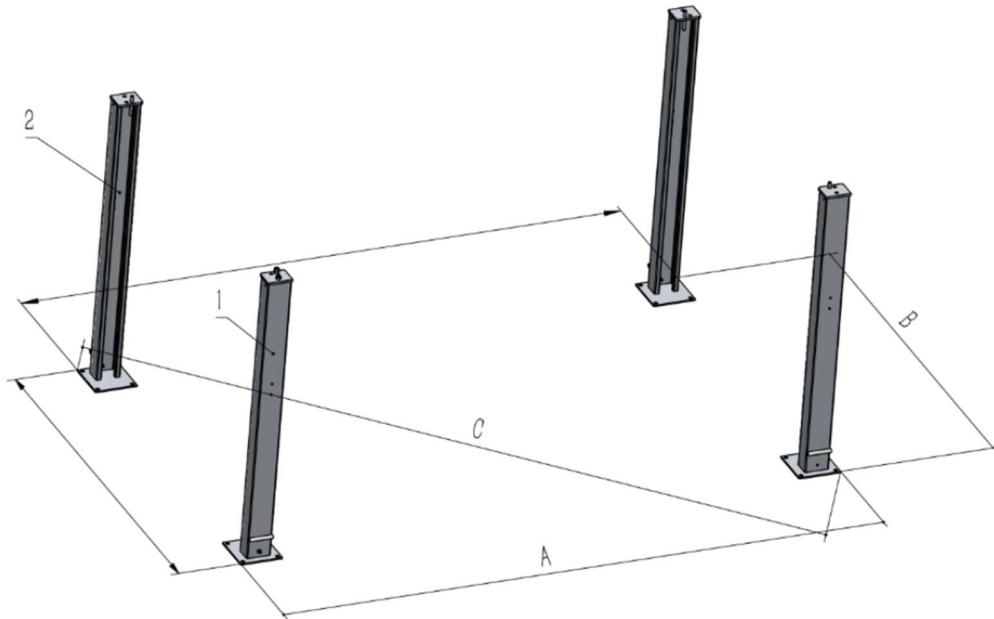

4.3T	<b>A</b>	<b>B</b>	<b>C</b>
4.3T	4805 mm 189.17"	2813.5 mm 110.76"	5568 mm 219.2"

Figure 11

Use a carpenter’s chalk line to establish installation layout as per table shown in Figure 11.

**⚠ CAUTION**

- ***Make sure to position the assembled lift in the final desired location (\*\*Ensuring that the posts are plumb\*\*) before drilling any mounting holes for the posts.***

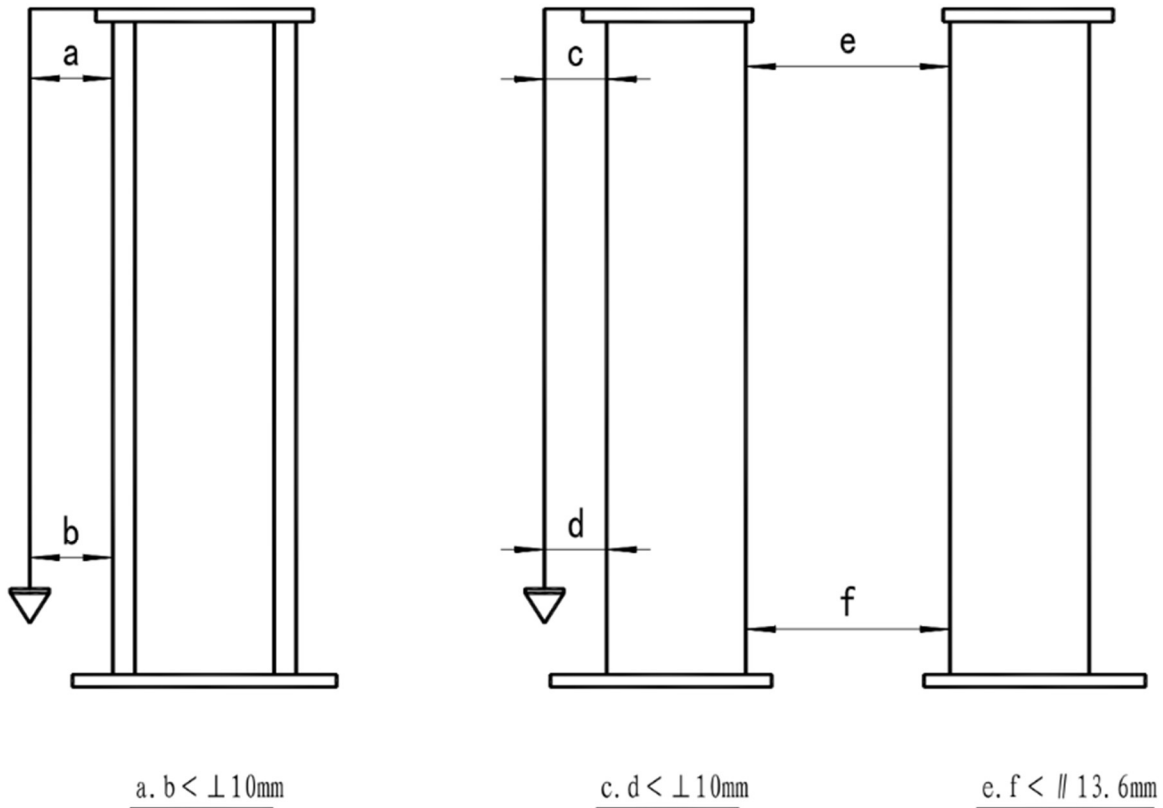

Figure 12

- ***All the dimensions are in millimeters and based on the external border of the base plate.***
- ***Ensure the variance of marking the above layout on the floor is controlled within 6mm. This will ensure elimination of any difficulties in the final assembly, or early wear or miss-alignment of the chain.***
- ***The marking and layout step is very important. Any inaccuracy in marking the layout can cause issues with the final assembly and operation.***

## **Post Assembly:**

### **Step 1 – Crossbeam Installation:**

Note: Pay attention that the Crossbeam's slot should be positioned inward and the safety locks connecting assy. should be adjacent to the power unit column.

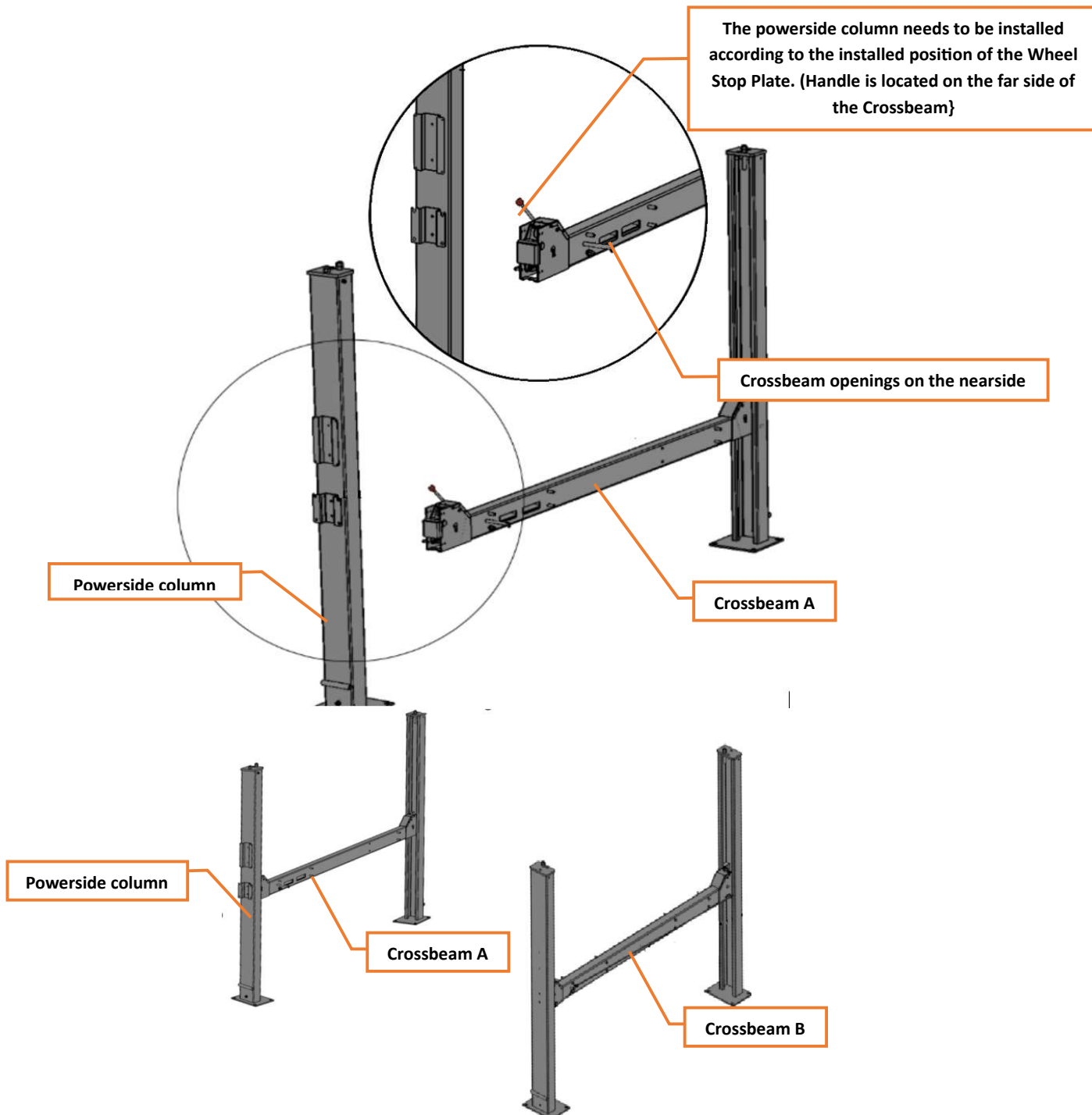
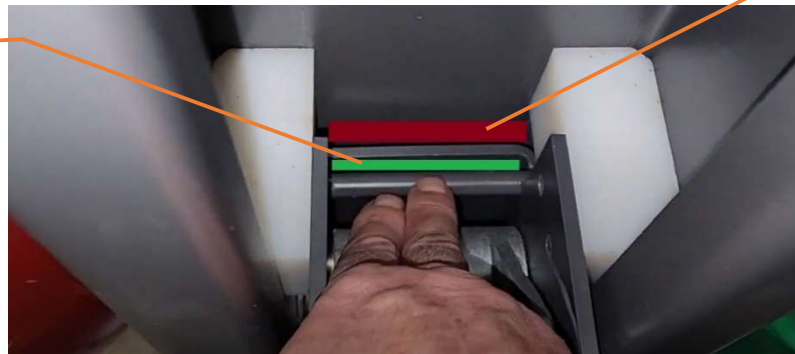
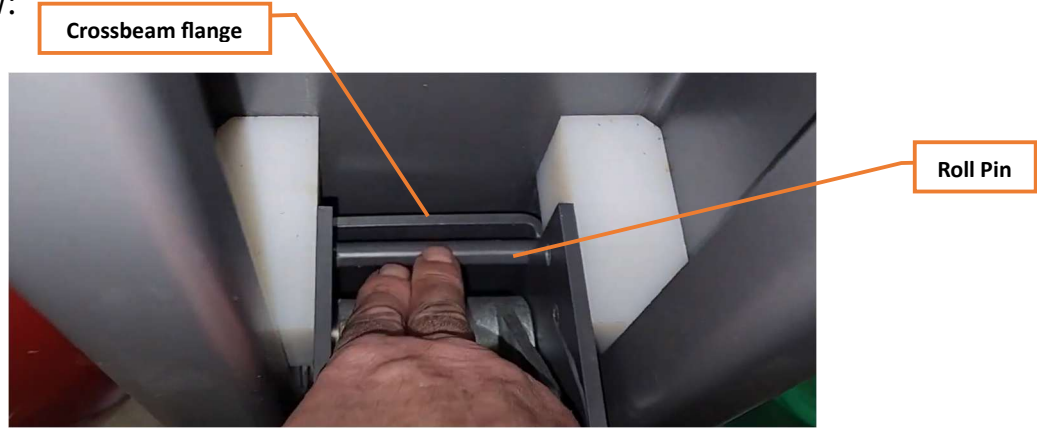
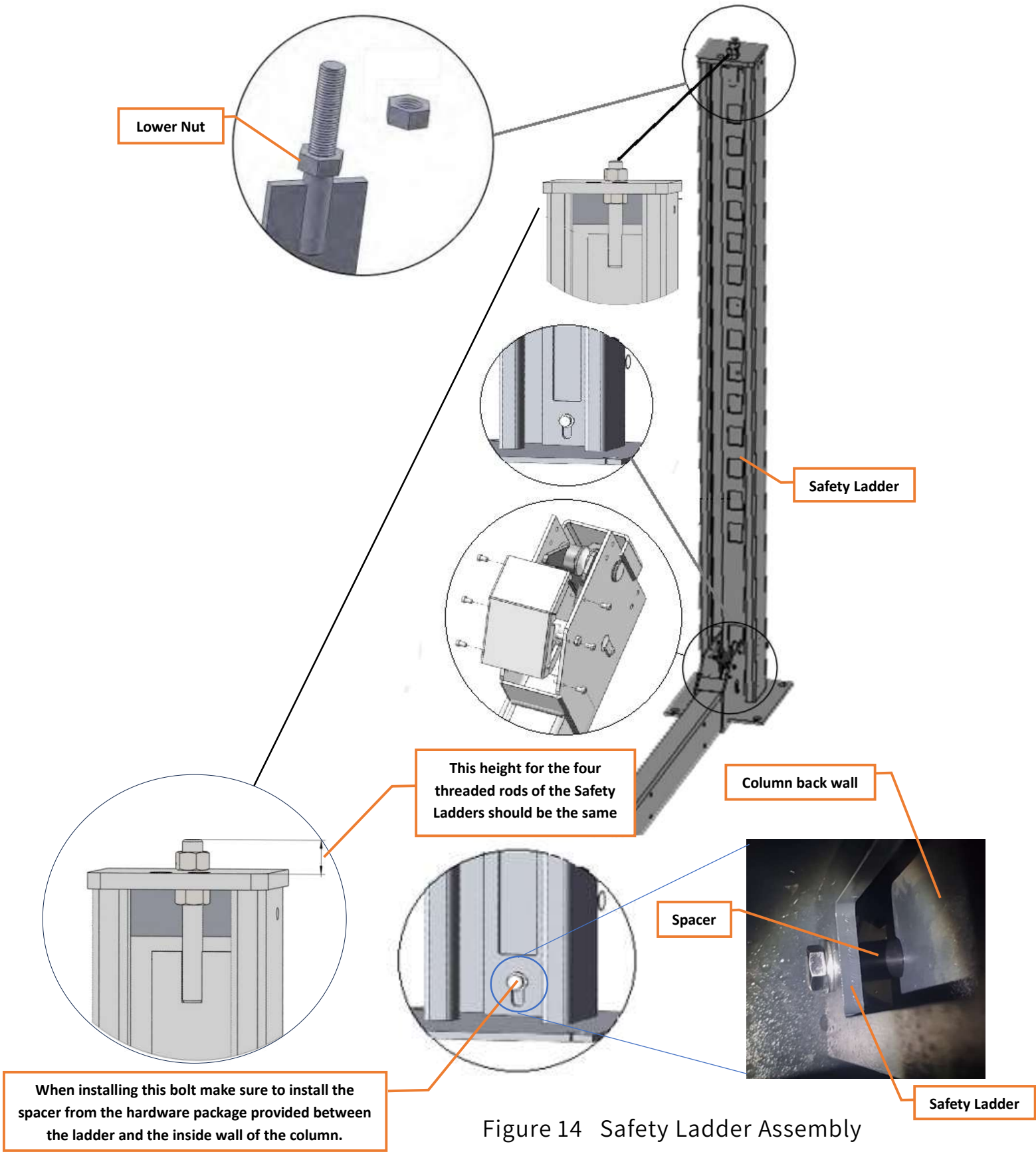

Figure 13 Crossbeam assembly

## Step 2 - Safety Ladder installation:

1. Remove the top plate from the column.
2. Adjust the four lower nuts so they are at the same position (See Fig. 14).
3. Install the Safety Ladder between the roll pin and the crossbeam flange as shown below:





**Step 3** - Raise the Crossbeams at the same height Approx. 39" (1m) and lock them on the Safety Ladders. Make sure that the safety release handle on the Crossbeam is engaged on all Safety Ladders.

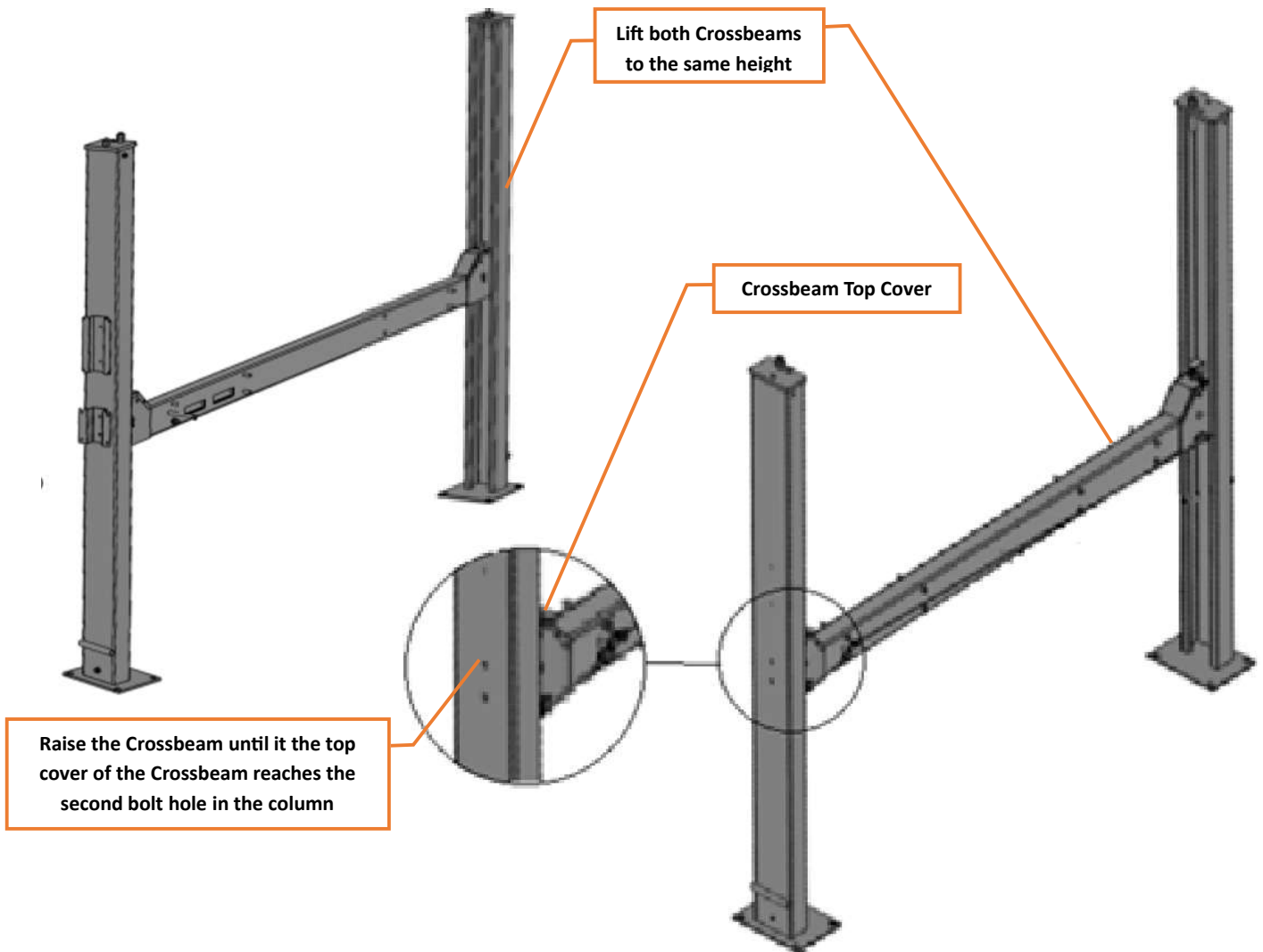

Figure 15

**Step 4 - Install Powerside Runway.**

1. Pull all 4 Wires Ropes (**Orange** Arrow shows pull direction) to completely extend the cylinder under the platform from both ends of the platform.



2. Raise the Powerside Runway above the Crossbeam by a forklift or crane.
3. Align the “two-pulley” end of the platform with narrow opening in the Crossbeam A.
4. Align the “four-pulley” end of the platform with larger opening in the Crossbeam B as shown below.

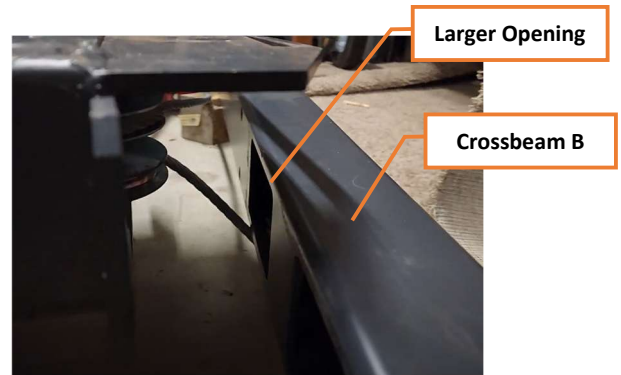
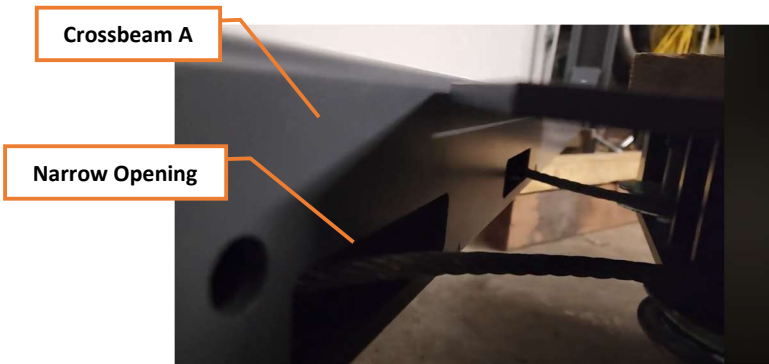

5. Pass the wire ropes through the openings (shown by the orange arrow) in the Crossbeams and the pulleys and secure them to the top plate of each column.



**6. For detailed instructions on how to run the wire ropes go to Step #8.**

7. Move the Crossbeam outwards until the pulleys of both platforms can be rested into the Crossbeams' slots (see Fig.16).

Illustration of front pulley in Powerside Runway

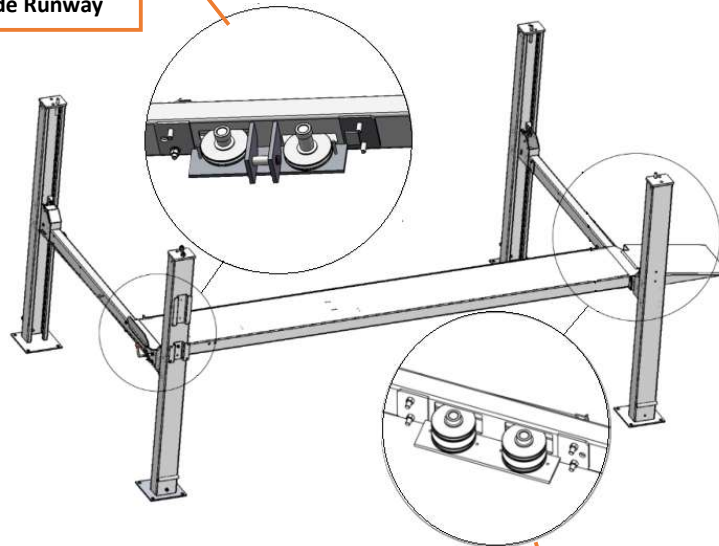

Figure 16

Illustration of rear pulley in Powerside Runway

**Step 5** - Install the Wheel Stop Plate and connecting bolts:

- 1) Fasten the platform to Crossbeam A (Do not tighten the screws at this point and wait to complete Step 6).
- 2) Fasten the platform to Crossbeam B (Do not tighten the screws at this point and wait to complete Step 6).
- 3) This lift is designed such that the vehicle can be loaded either from Crossbeam A or Crossbeam B. Insert the Wheel Stop Plate in the slot in the platform opposite of the vehicle entry Crossbeam.

**CAUTION**

**Note:**

- *Make sure to pick the correct length bolts to install the platforms. (See Fig.19)*
- *Powerside column can be installed at any position. But the power unit must always be installed adjacent to the safety release handle. Pay attention to direction when installed the safety release handle, power unit and hydraulic system.*

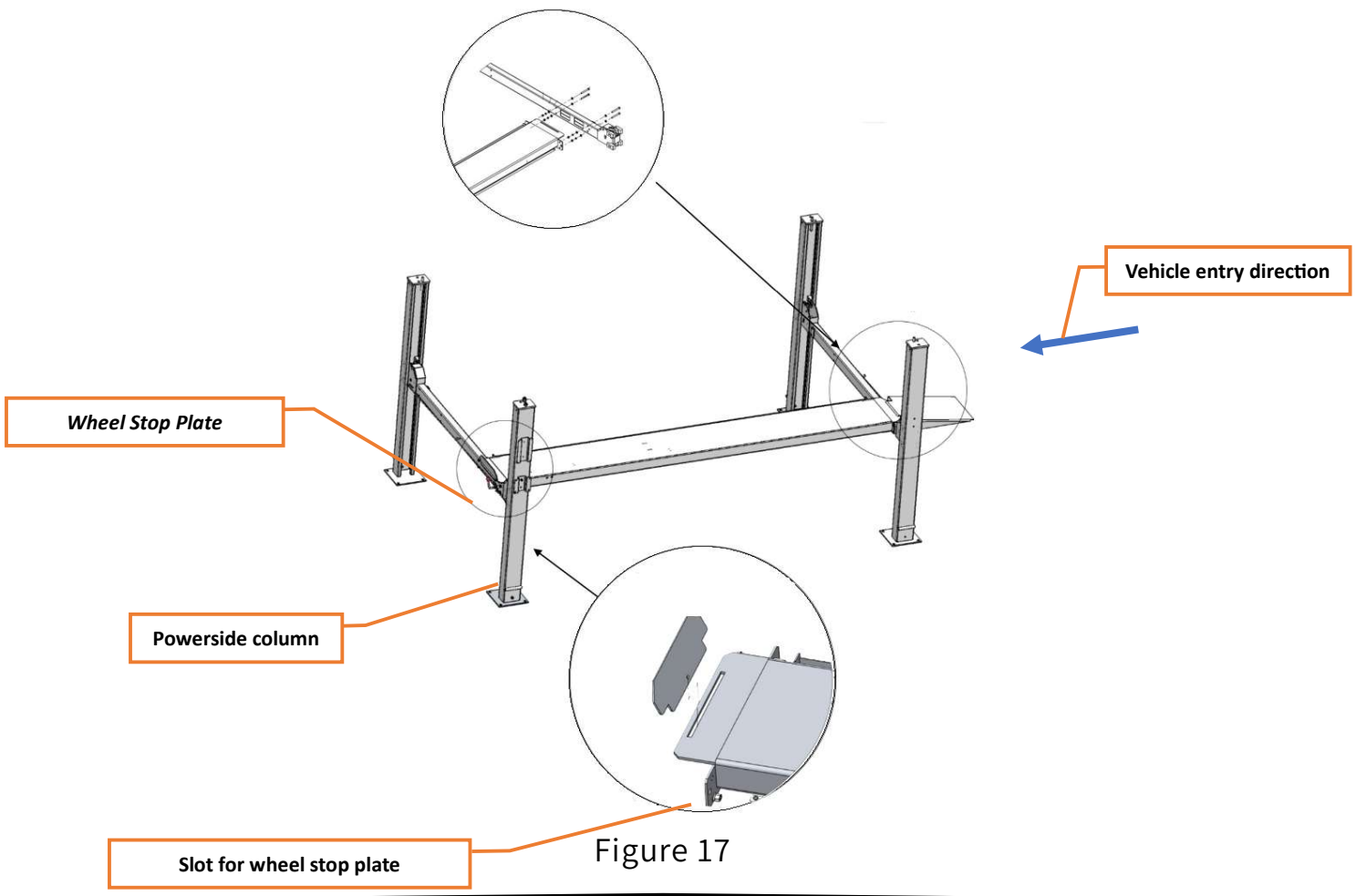

**Step 6** - Install the Offside Runway and Wheel Stop Plate.

**CAUTION**

Ensure that all columns are plumb and adjust with shims if needed. (See Fig. 12). Tighten all screws for both Powerside and Offside Runways once both platforms are placed on the Crossbeams.

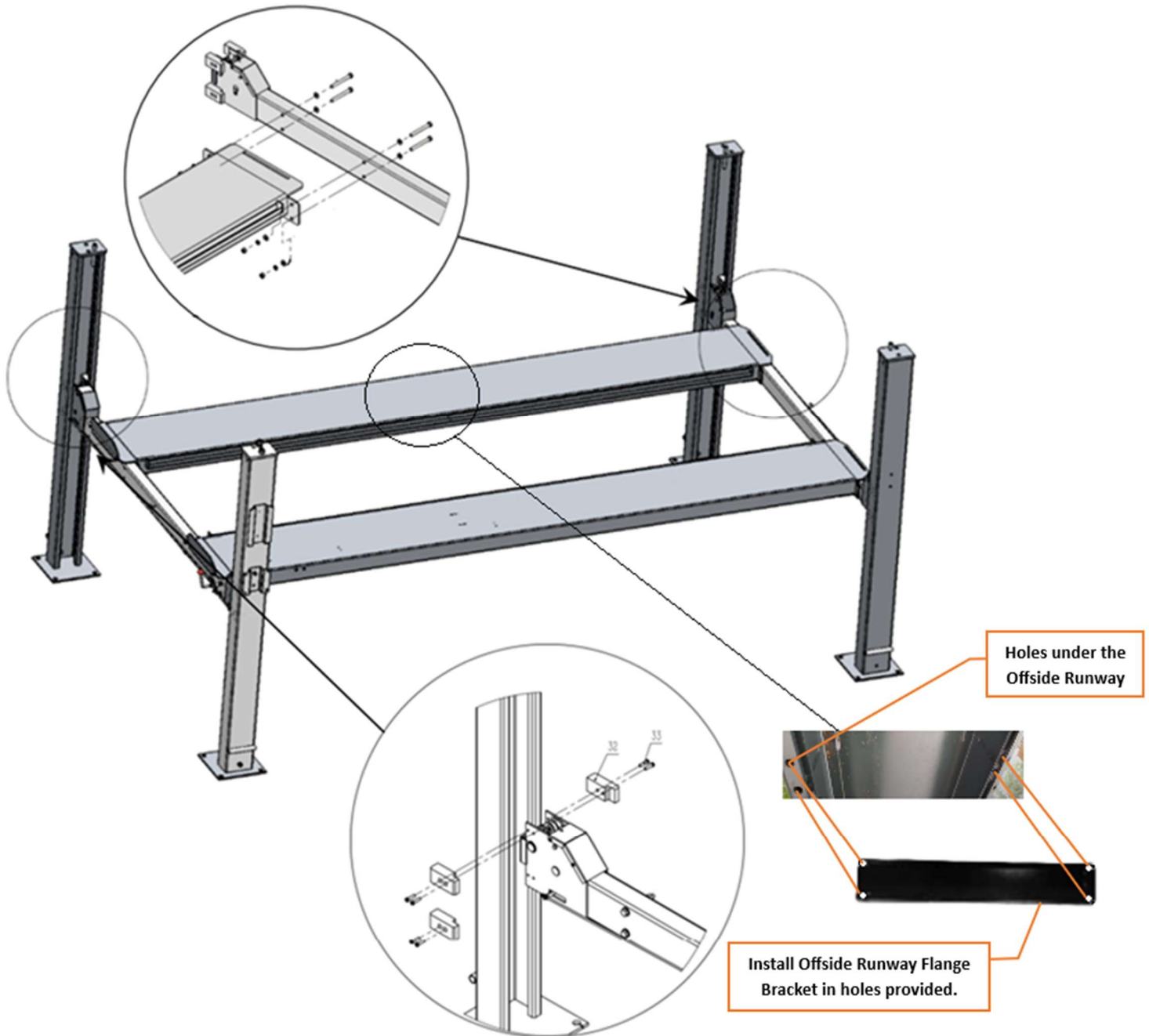

Figure 18

**Step 7 - Power Unit and Hydraulic Line Installation:**

- 1) Install the power unit after fastening the mounting bracket as shown below.
- 2) Connect the safety release handle in crossbeam A to the safety release mechanism in crossbeam B by using the connecting rod as shown below.

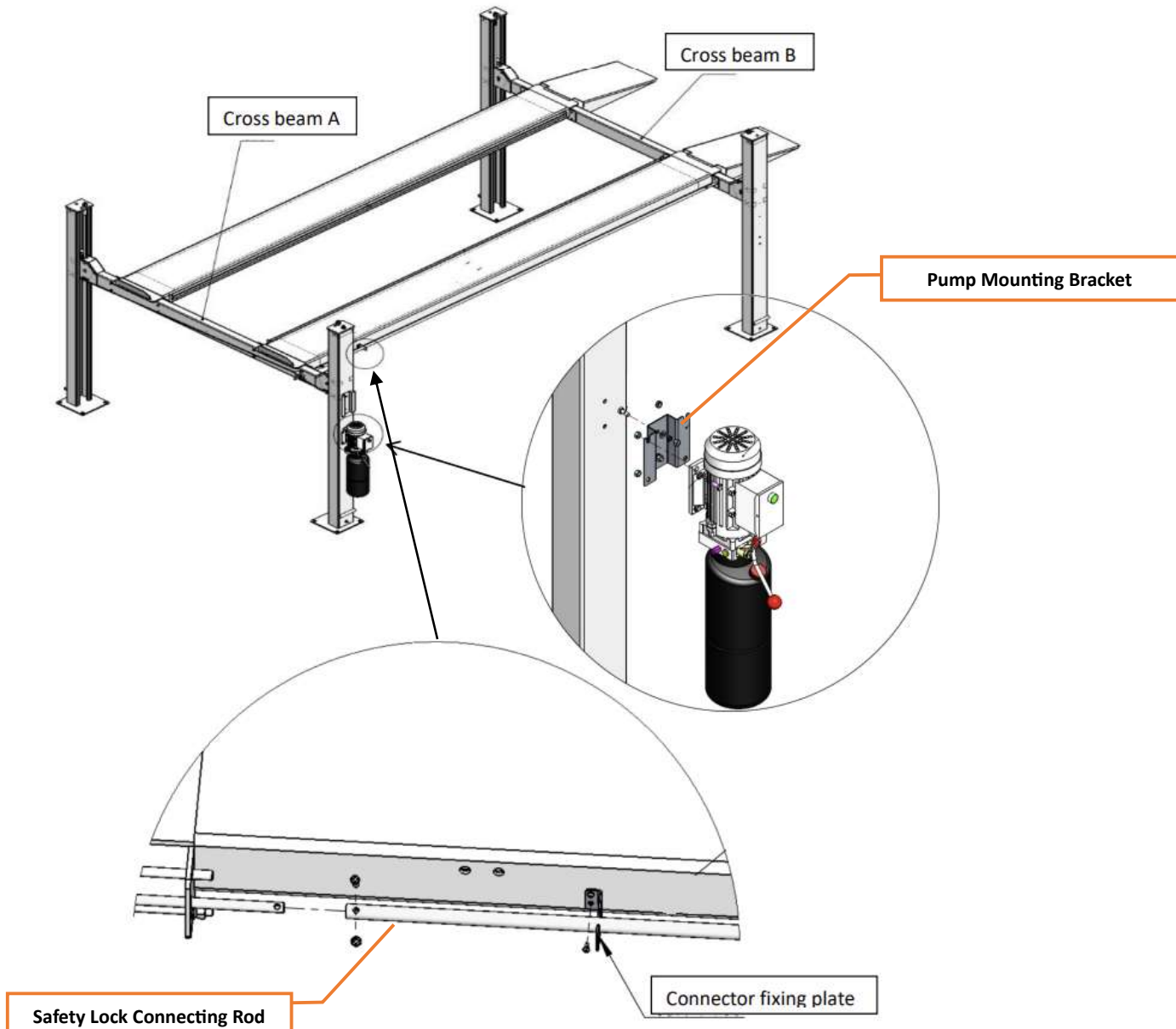

Figure 19

3) Use four M10 Bolt s and washers to install the power unit (as shown in Fig. 20).



Figure 20

4) Connect the Hydraulic line from the pump to the platform cylinder return fitting as shown below and tighten all the fittings to prevent oil leakage.

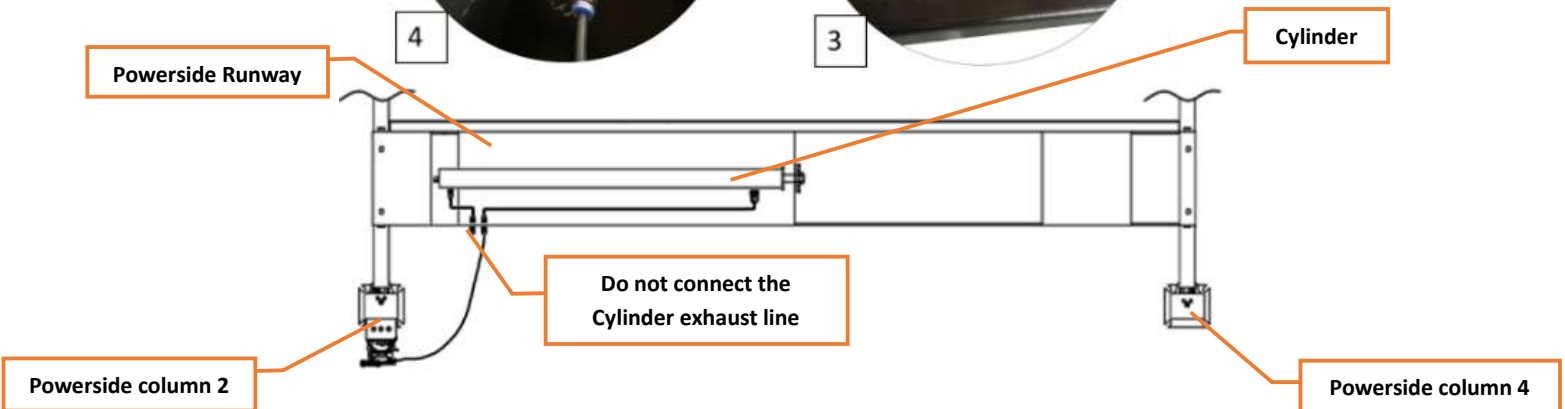
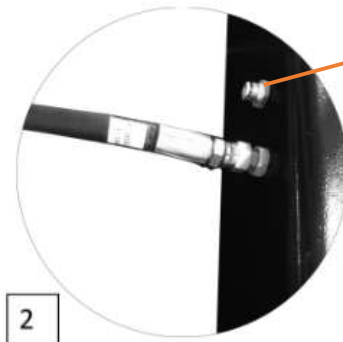

Figure 21

# CAUTION

## Note:

- Clean the impurities in the hydraulic line and remove the protective plug from the hydraulic cylinder.
- When the hydraulic hose installation needs to go through the column, ensure the hydraulic hose won't touch any movable parts inside the column

5) Fill the reservoir with hydraulic oil N32 or N46 (oil capacity of 10L) to the oil reservoir of the power unit up to Max Fill Mark on the oil level dip stick. Fill the reservoir carefully to avoid dust and other pollutants to mix with the hydraulic oil.



6) Hydraulic Power Unit Functional Description:

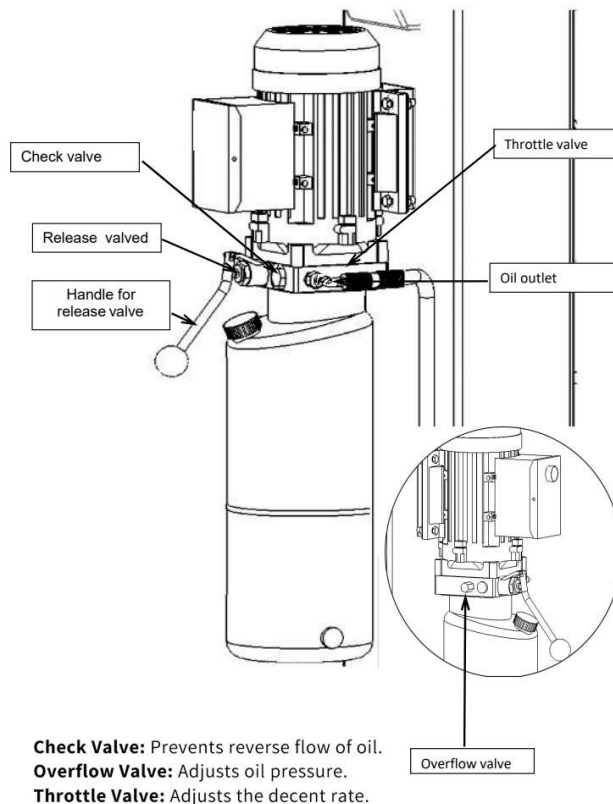

**Step 8 – Wire Rope (Balancing steel cable) installation:**

1. Make sure that there are no hydraulic lines connected between the cylinder and the pump.
2. Extend the platform cylinder by pumping air in the cylinder extend port as shown below:

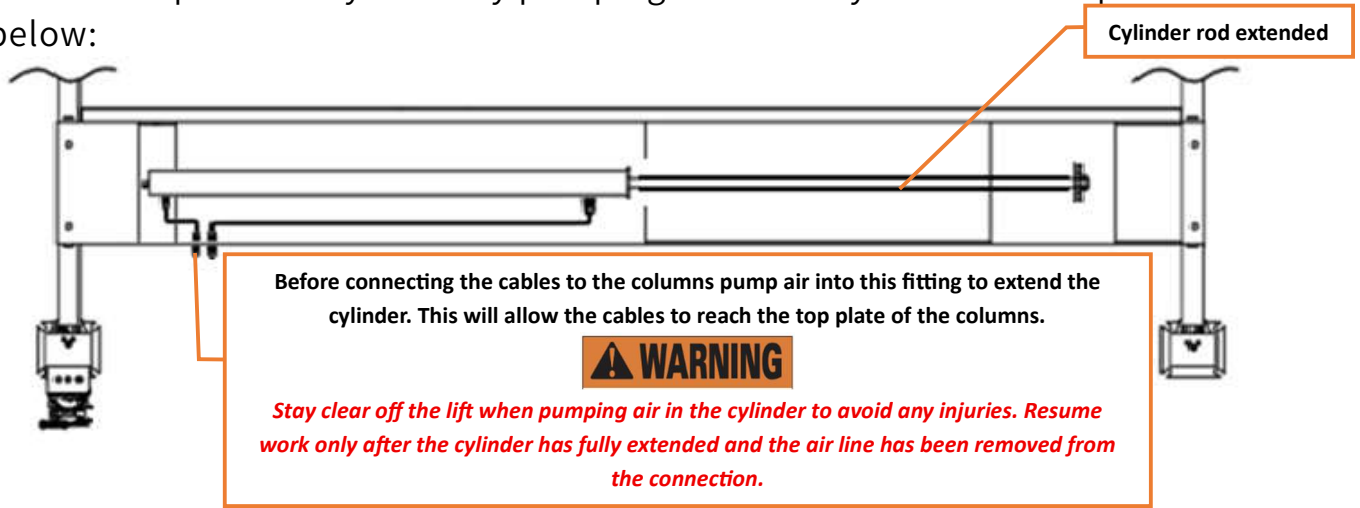

3. Route the wire ropes from the Powerside Runway via the pulleys based on the diagram below. The table below identifies the length of steel cable going to each column. and then connect them to the columns.

**⚠ CAUTION**

4. Make sure to install the cable loops around all pulleys before setting up the tension in the cables.

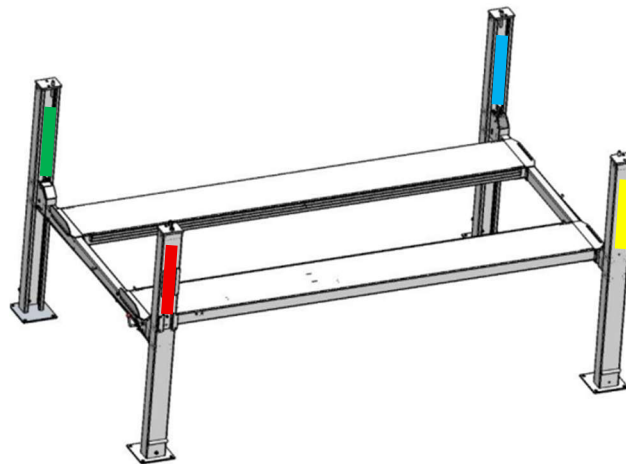

Wire Rope #	①	②	③	④
Length	8980 mm (354")	7420 mm (292")	4500 mm (177")	2930 mm (115")

Figure 22: Wire Rope Length table

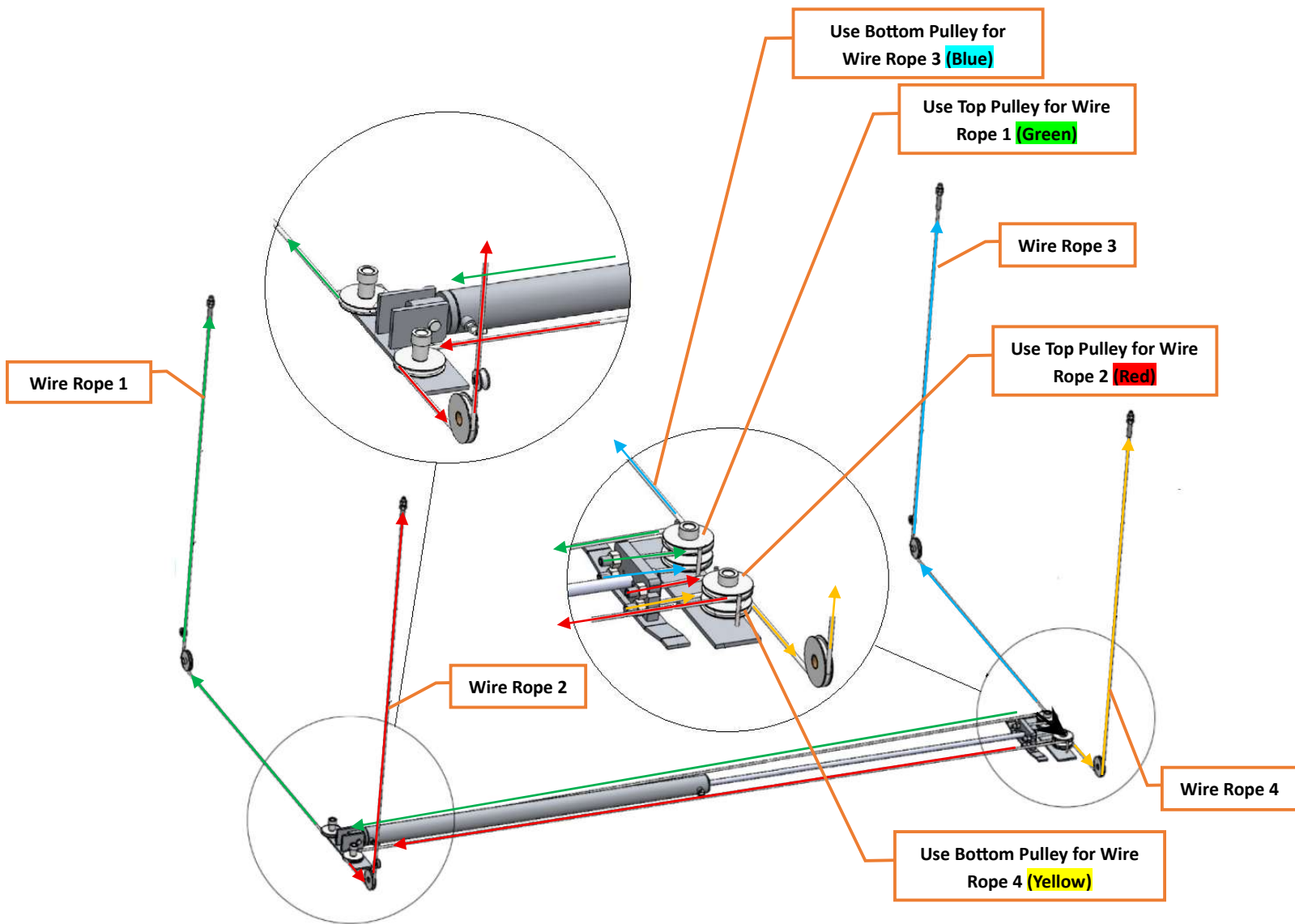

**CAUTION**

When feeding the wire ropes through the Crossbeams A and B ensure all wire ropes run in the **Green zone** between the top and bottom

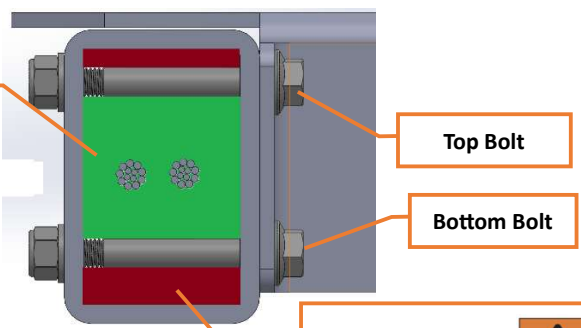

**WARNING**

*Do not feed any wire ropes in the Red zones of crossbeam A and B. Running the wire rope under the bottom bolt or on top of the top bolt can cause severe catastrophic damage to the lift.*

Figure 23: Wire Rope Installation

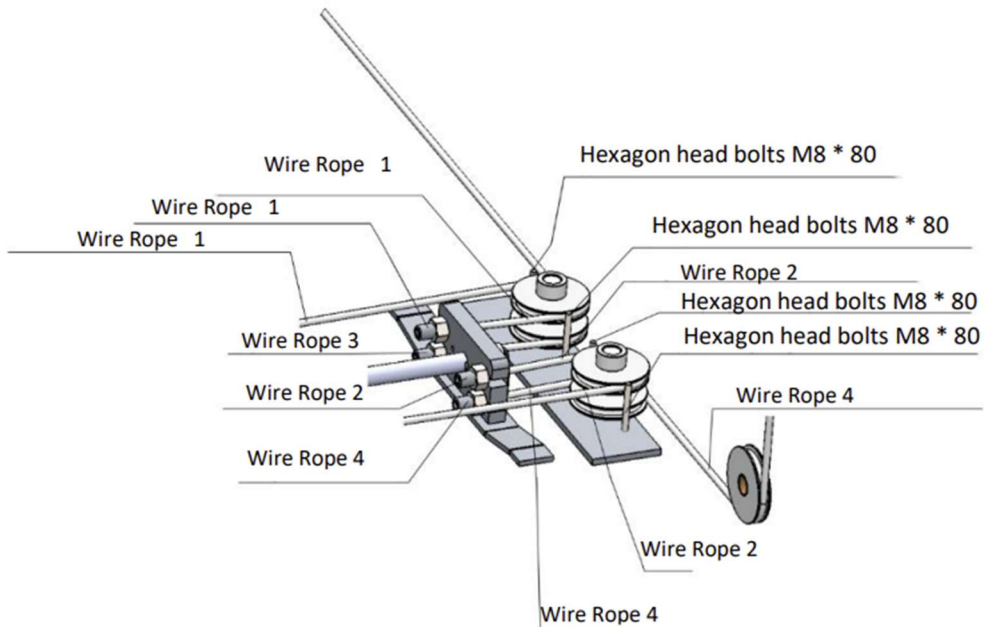
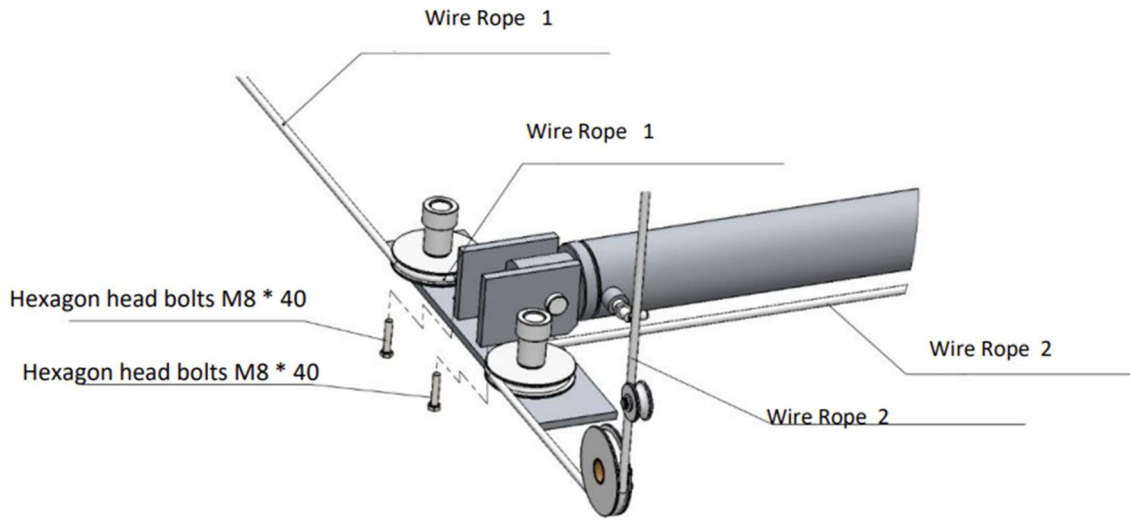

Additional Reference Details for Pulleys

**Step 9** - Install safety release handle Assy.

Noted: Power unit must be installed near the safety release handle.

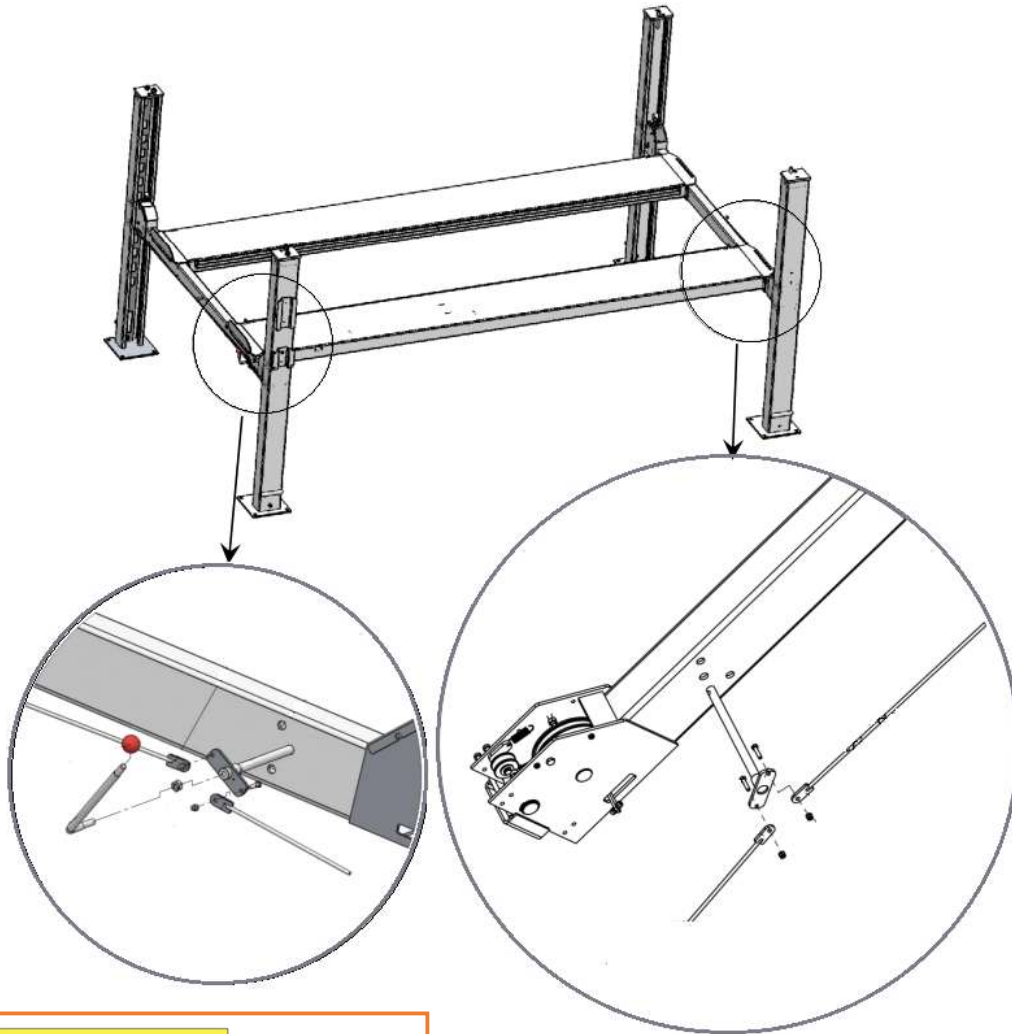

**CAUTION**

When installing the 4 connecting linkages for each column make sure to install the plastic retainer guide as shown



Figure 24

**Step 10** - Install drive-in ramp, optional jack tray and optional oil pans (See Fig.25). then attach the drive-in ramp:

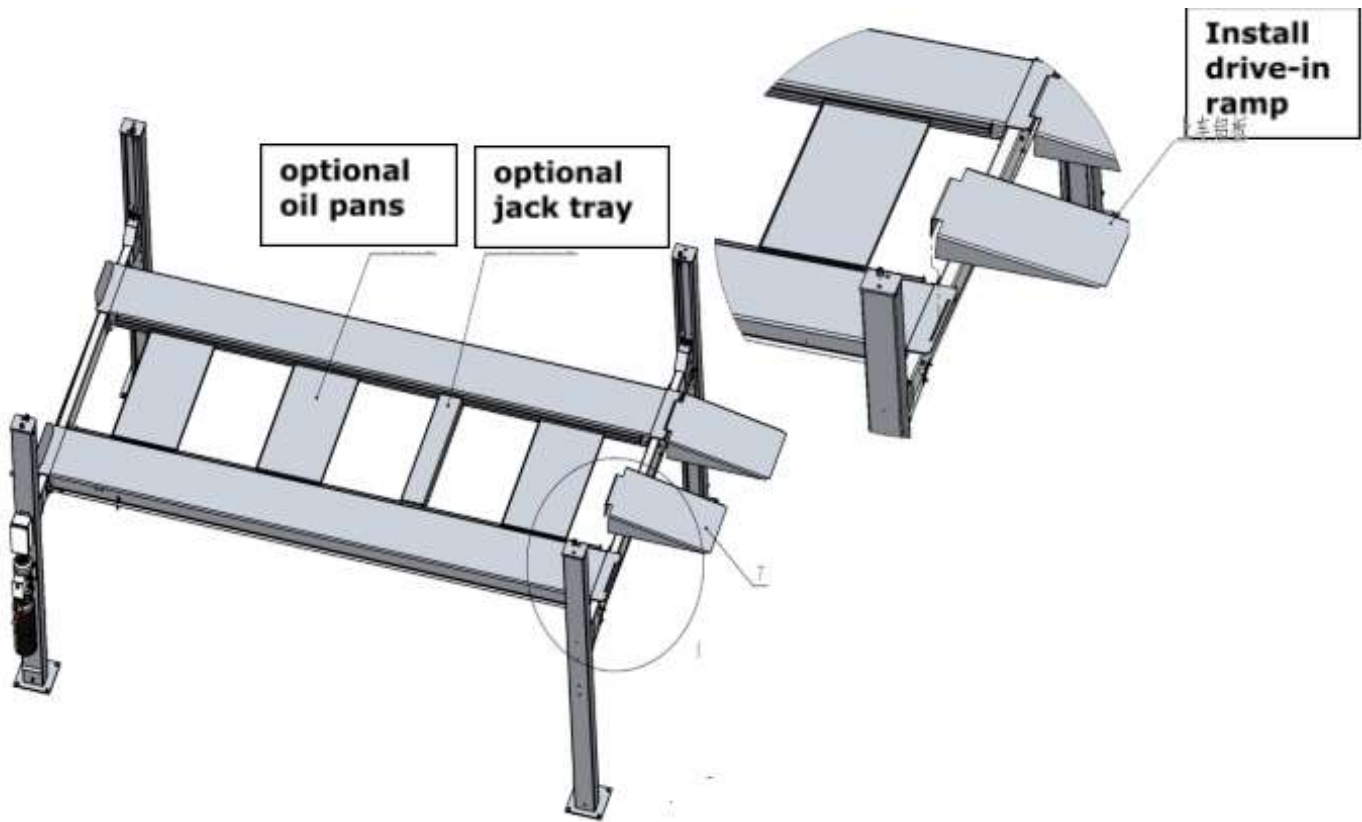

Figure 25

**Step 11** - Install spring and beam safety cover of Crossbeam (See Fig.26).

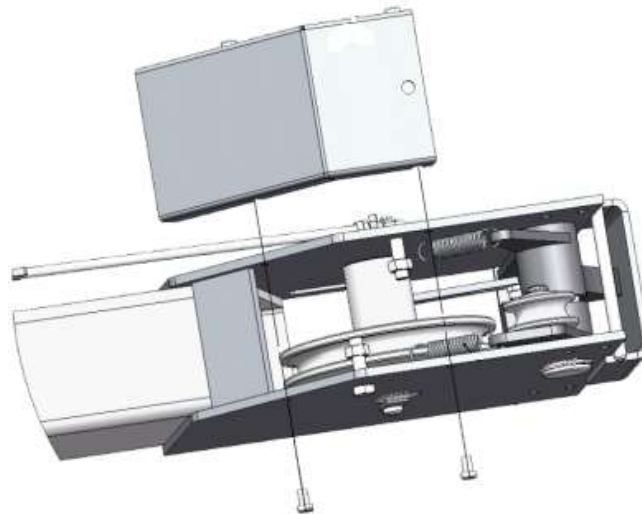

Figure 26

**Step 12** - Install caster kits

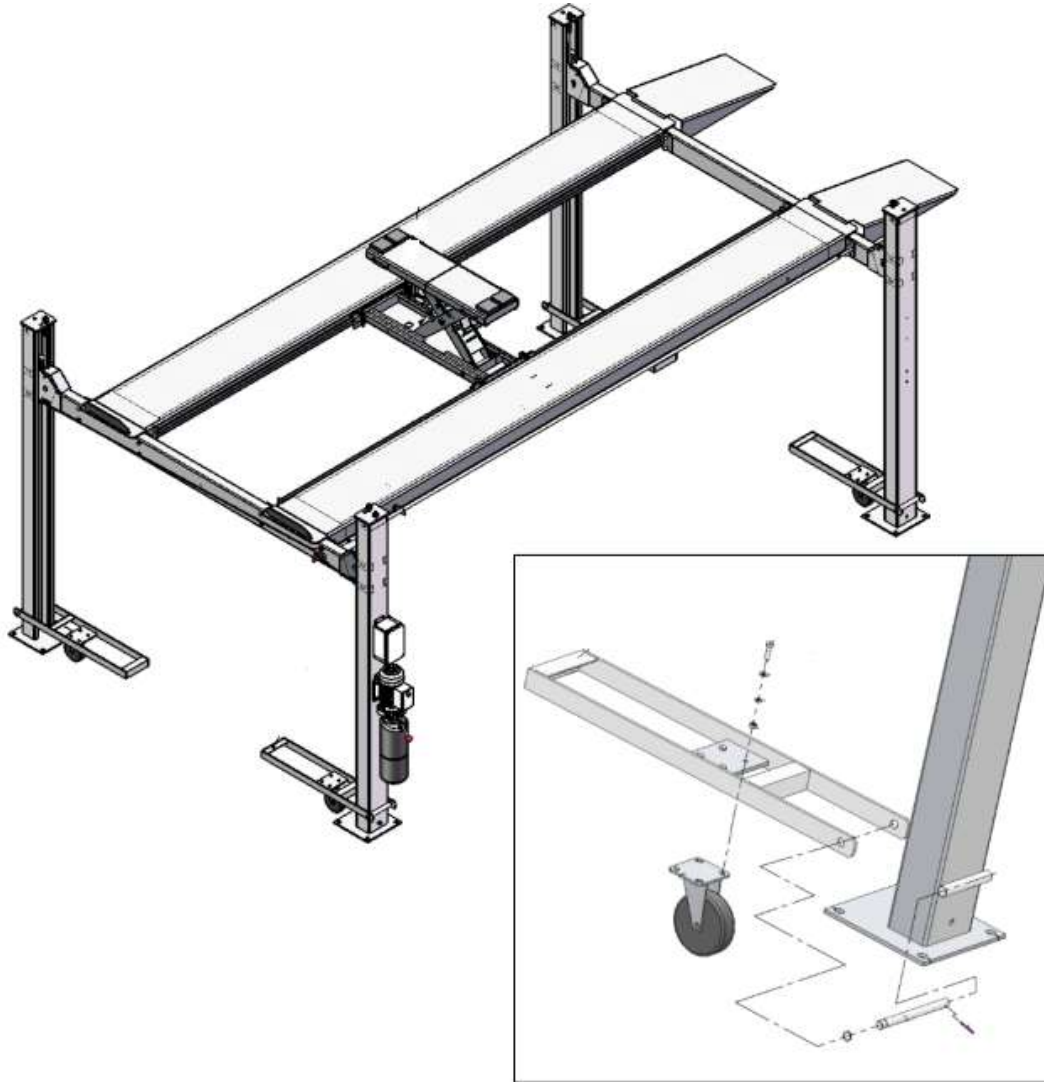

Figure 27

**(Optional) Step 13** - Install the anchor bolts:

If the casters from step 12 are not used, the lift can be anchored to the concrete.

During the drilling process, ensure there is no movement of the columns. (see Fig. 11).

1. Prepare the anchor bolts shown below:



2. Lift can only be installed on concrete slab, which must have a minimum thickness of 5.9" (150mm) with a 3000 PSI rating or more and should be aged at least 7 days.

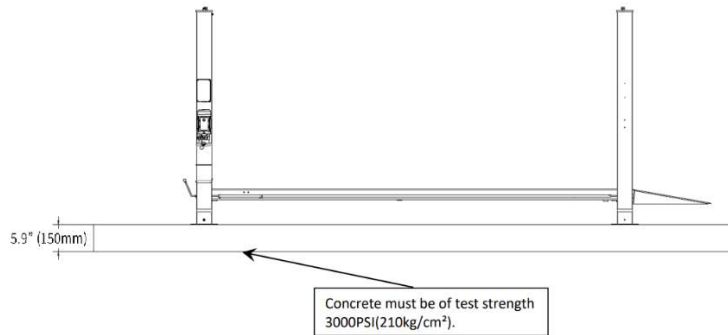

Figure 28

3. Don't install the lift on any asphalt surface or any surface other than concrete.
4. The concrete slab should be reinforced using steel bar.
5. The concrete slab must be level.
6. Check for possible obstruction, e.g. low ceiling height, wireways, conduits, overhead pipeline, walkways, exits, etc.
7. The front and back of the lift should be reserved with sufficient space to accommodate all the vehicles.
8. Adequate space around the lift should be provided based on local fire and evacuation safety code.
9. Don't install the lift on the concrete with seams or cracks and defects.
10. Adjust the column with the leveling bar and leveling pad, drill the anchor hole and install the anchor bolts. Tap the anchor bolts into the anchor hole with a hammer and tighten the bolts. (See Fig.29)

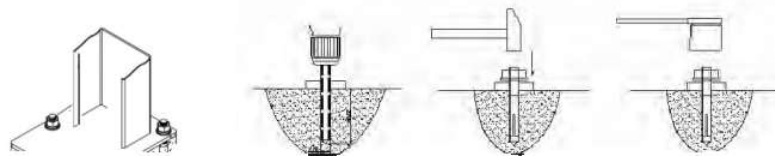

Figure 29

## CAUTION

11. Make sure to get the post installation inspected and certified by an architect.
12. Without the written approval of the architect, don't install the lift on a second floor or a floor with a basement.

## CAUTION

13. Overhead obstruction: The lift installation area can't have any overhead obstruction, such as HVAC system, building support, electrical pipe, utility lines/conduits etc.
14. When selecting the location for the lift make sure there is enough ceiling clearance.
15. Concrete drilling test: The installation personnel can test the concrete strength by performing the concrete drilling test. If several lifts are installed at one place, it is preferred to complete a drilling test on each site.

## CAUTION

### **Note:**

- ***Make sure to position the assembled lift in the final desired location (\*\*\*)Ensuring that the posts are plumb\*\*\*) before drilling any mounting holes for the posts.***
- ***Use sharp  $\Phi$ 19mm concrete drill-bit to drill the holes and avoid an oversized hole. Use a proper vacuum tool to remove the dust from the hole. The hole should not exceed 4-3/4" (108mm) deep in the concrete. Install the anchor Bolt. Place the flat washer then the lock washer and then install the nut.***
- ***Only use torque wrench instead of impact tools to fasten anchor bolts.***
- ***Insert proper steel shim under the base seat of column to plumb the column.***
- ***Note: The thickness of shims shouldn't exceed 5mm.***

## WARNING

To ensure correct and safe installation, please follow the following safety steps.

- Wear the safety goggles.
- Use a hard alloy drill-bit.
- Don't use a worn-out drill bit.

- Make sure to drill the hole perpendicular to the concrete surface.
- Let the drill work itself. Don't apply the extra force, and don't ream the hole or allow the drill to wobble.
- The drilling depth of hole is based on the length of anchor Bolt supplied in the hardware package for the lift. The distance from the Bolt head to the concrete floor should be more than twice the Bolt diameter.
- Remove the dust from the hole.
- Gently tap the Bolt into the hole and fasten the nuts.

## **10.0.2 Electrical Installation:**

The lifts are offered in two electrical configurations:

- 110VAC/60HZ/1PH
- 220VAC/60HZ/1PH

Locate the serial number plate on power side post as shown below or the pump serial number plate to locate the voltage required for the equipment as shown below. Make sure to hire a professional electrician to connect the power to the junction box on the pump.

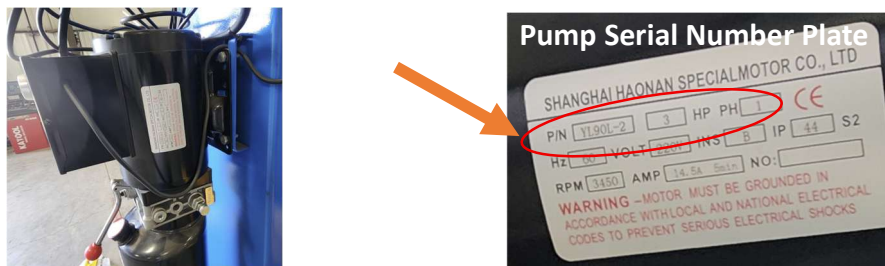

### **Wire Color Coding**

**Brown** = Hot Leg

**Blue** = Neutral (may also serve as a 2nd hot leg in 220V setting)

**Green/Yellow** = Ground

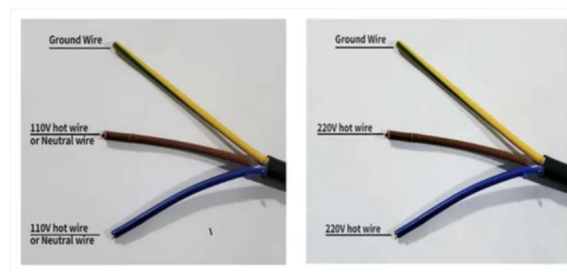
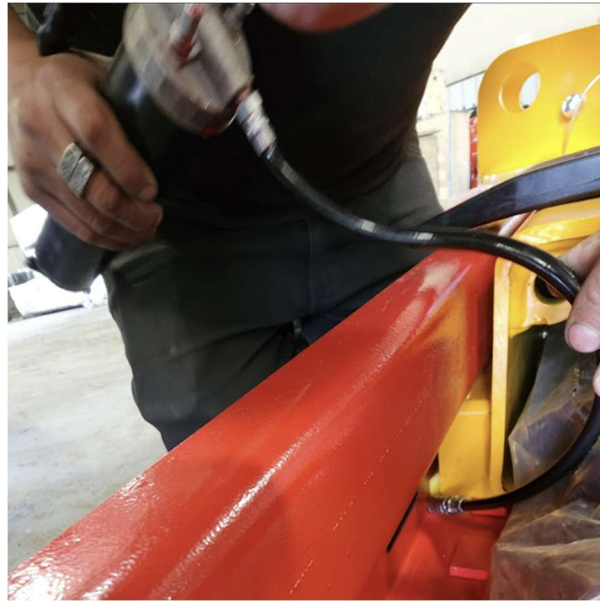

Figure 30

### **10.0.3 Lift Adjustment:**

Preparation before the adjustment:

- Lubricate contact surface of the Crossbeams and corners of columns with general-purpose lithium grease. All sliding surface should be coated evenly from top to bottom.



Adjustment procedure:

- Check to see if the power is connected properly.
- Check to make sure that all fasteners and bolts are secured tight.
- Press the start button till the cables are strained.
- Check the cables and confirm they are all on their correct respective pulleys.
- Make sure the cables are not crossing or rubbing on top of each other.
- When the Power Unit pressure relief valve is pressed down, the Crossbeams will come down and will stop on an opening in the Safety Ladders.
- At this point make sure that both Crossbeams A and B and the platforms are level.
- If the platforms are not level. Level them by adjusting the nuts of Safety Ladders in each column.

- Once the platform is level, tighten the **Safety Ladder top and bottom nuts** to lock the ladder position.

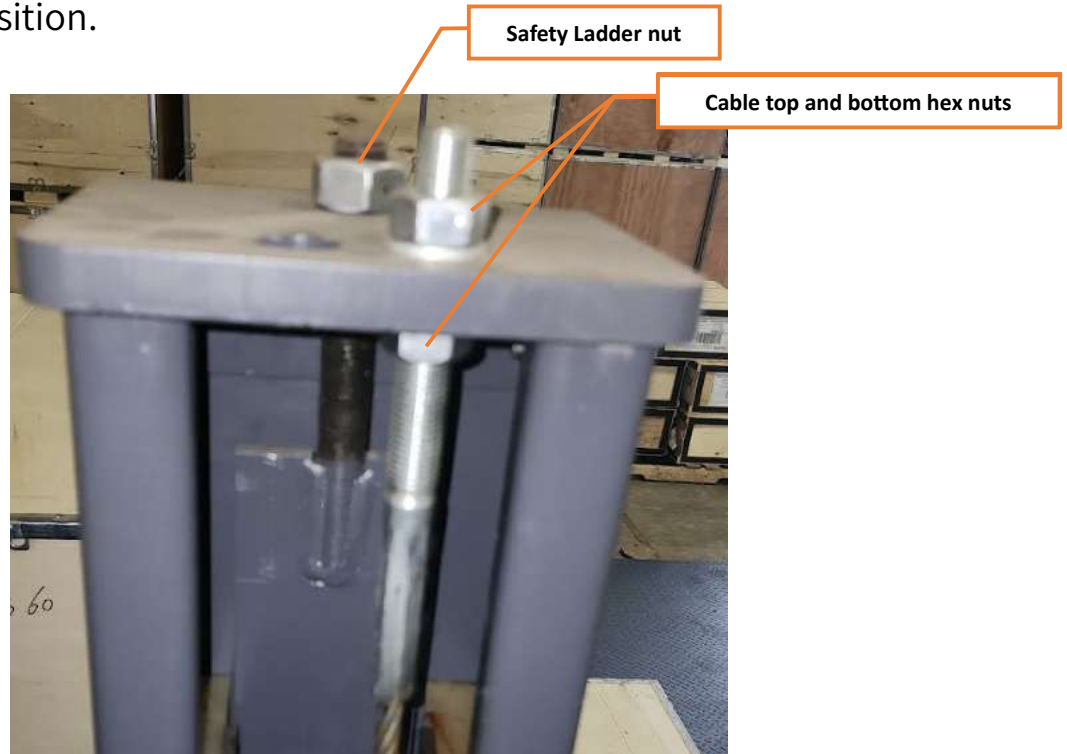

- Adjust the **cable hex nuts** to make the platforms and four safety locks work synchronously.
- Run the lift up and down for several times, while making the synchronous adjustment till the four safety devices can lock and release at the same time.
- After finishing the above adjustment, test running the lift with load.
- Lower the lift with platforms to the lowest position first, make sure the platforms can raise and lower synchronously and the safety device can lock and release synchronously.
- Next run the lift by lifting it to the top completely.
- Repeat the above adjustment until you achieve a level platform in all positions.

## 10.0.4 Bleeding a 4-post lift

### **CAUTION**

#### *Safety First*

- *Make sure the lift is empty (no vehicle on it).*
- *Use jack stands or blocks to support the platform if needed.*
- *Do not put your hands or body under the platform while performing this procedure.*

#### Steps to Bleed a 4-Post Lift

- 1) Raise and Lower the Lift Repeatedly
  - Fully raise the lift using the power unit.
  - Let it go as high as it can (safely), then slowly lower it back down.
  - Repeat this process 6–10 times.
  - This motion allows trapped air to move toward the hydraulic reservoir.
- 2) Check Hydraulic Fluid Level
  - After cycling, lower the lift completely.
  - Open the power unit reservoir and check fluid level.
  - Top it off with the correct hydraulic fluid (usually AW32 or ISO 32 unless specified otherwise).
  - Be sure not to overfill — keep it just below the fill hole.
- 3) Inspect for Leaks or Air Ingress
  - Make sure all connections are tight.
  - If air continues to enter the system, check for damaged seals, hoses, or fittings.
- 4) Signs the system is properly bled
  - The lift raises evenly.
  - No jerky or slow movements.
  - No unusual noises (e.g., gurgling).
  - No noticeable drop or sag when stopped.

## **11.0 SAFETY INSTRUCTIONS**

Contact with line power voltages can cause death or serious injury.

- **Do not operate equipment with a damaged power cord.**
- **If an extension cord is necessary, a cord with a current rating equal to or greater than that of the equipment should be used.**
- **Do not expose the equipment to rain or wet environment.**
- **Make sure to connect the unit with proper electrical power.**
- **Use a certified electrician to connect the electrical power.**
- **Do not remove or bypass grounding pin.**
- **Only qualified service personnel should service this equipment.**
- **Disconnect power to the unit before servicing.**

Contact with moving parts could cause injury.

- **Keep hands and other body parts away from moving surfaces.**
- **Do not bypass any safety features.**
- **During the lifting and lowering of the lifting platform, stay clear of the moving parts of the lift. The operator needs to confirm that there is no one in the hazardous area before the lifting operation. (Figure 31)**

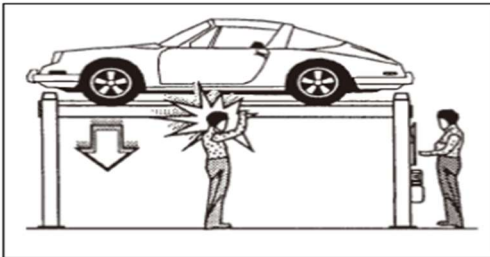

Figure 31 - Risk of injury under the platforms

- **When the height of the lifting platform is less than 1.75 meters; relevant personnel should avoid hitting their heads when entering the platform. (Figure 32)**

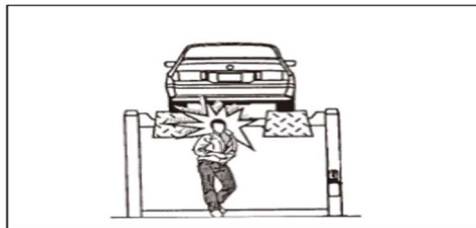

Figure 32 - Impact risk

- An improper docking of the vehicle on the lifting platform, improperly parking the vehicle, or an oversized vehicle that does not match the lift specifications can cause the vehicle to fall at risk. (Figure 33)

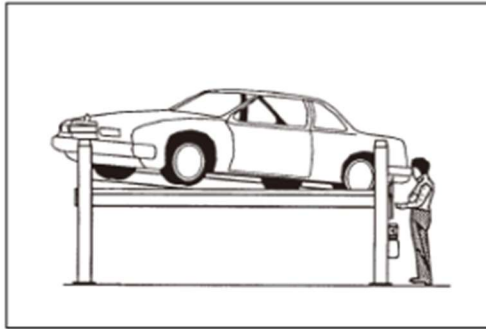

Figure 33 - Improper docking of vehicle

- It is not allowed to stand or sit on the lift platform during lifting operation. (Figure 34)

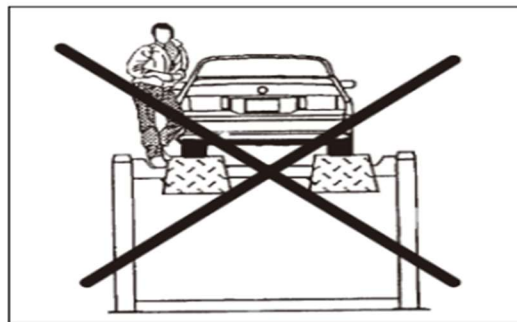

Figure 34 - Risks caused by unreasonable use

Debris, dirt, and fluids can cause serious eye injury.

- Wear approved safety glasses during mount and demount procedures.
- Lubricating oil around the lift can cause slip risks. The area around the lift, below and on the top of the platform must be kept clean. Make sure to clean up the oil spills promptly. (Figure 35)



Figure 35 - Slip and fall risk

Tools that break or slip can cause injury.

- **Read and understand the operation instructions before using the equipment.**
- **Frequently inspect, clean, and lubricate (if recommended) where designated.**

## **12.0 Sales and Tech Support Contact info**



## **Contact Info**

**Main Phone Number: (888) 636-1918**

**Sales:** Ext. 101

sales@autokato.com

**Tech Support:** Ext. 102

(please follow voicemail prompts for fastest assistance or fill out our technical support form [here](#))

technical.support@autokato.com

**Commercial Accounts:** Ext. 103

info@autokato.com

**Amazon, eBay and Temu Purchase Inquiries:**

Please send us a message directly on the platform where you made your original purchase.