

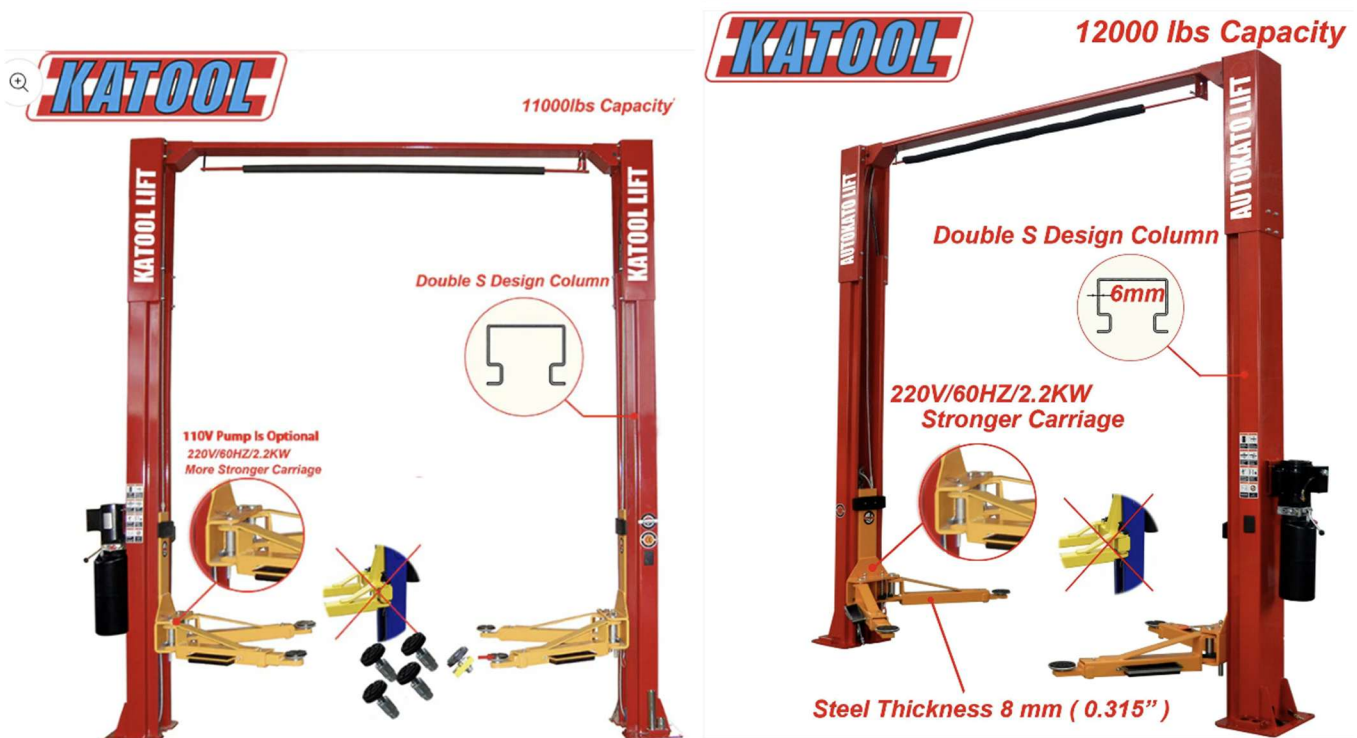

Two-Post Lift KT-M110/ KT-M120



TWO-POST VEHICLE LIFT

READ THIS ENTIRE MANUAL BEFORE INSTALLATION & OPERATION BEGINS.

Product/Item Code	Two post lift / 771.304
Brand	
Model	
Colour	
Voltage	
PO No.	
MADE IN CHINA	



This information is required when calling for parts or warranty issues.

PRODUCT WARRANTY

Our comprehensive product warranty means more than a commitment to you; it's also a commitment to the value of your new KATOOL lift. For full warranty details and to register your new lift contact your nearest KATOOL dealer or visit:

www.katoolautoequip.com

We offer a limited one-year (12 months) warranty on all parts and against all product defects, free of charge to our customers, **on all equipment**.

* Including but not limited to: Cylinders, power units, motors, displays, electronics, etc. Vehicle lifts will include an additional three-year (36 months) warranty on all lift **structural components only**.

Warranty claim for all products must fall within above period in order to qualify for limited warranty.

Warranty is non-transferable, must have original order number, and purchased from our company or a registered vendor. Replacement Parts will be provided at no cost to the customer and will include free shipping.

All warranty claims submitted to KATOOL are subject to approval by the warranty vice department and may be approved or denied at the full discretion of these departments. Photos and/or videos of original defects may be requested. Customers should not disassemble any piece of equipment before proof of original problem/issue has been determined.

What is NOT covered under this warranty:

- a. Any failure that results from Purchaser's abuse, neglect or failure to operate, maintain or service product in accordance with instructions provided in the owner's manual(s) supplied.
- b. Any damage caused by overloading lift beyond rated capacity.
- c. Items or service normally required to maintain the product, i.e. lubricants, oil, etc.
- d. Items considered general wear parts such as rubber pads, lifting cables, etc. unless wear or failure is a direct result of manufacturer defect due to material and/or workmanship.
- e. Any component damaged in shipment or any failure caused by installing or operating lift under conditions not in accordance with installation and operation guidelines or damaged by contact with tools or surroundings.
- f. Motor or pump failure caused by rain, excessive humidity, corrosive environments or other contaminants
- g. Rusted components due to improper maintenance or corrosive environments.
- h. Cosmetic defects that do not interfere with product functionality.
- i. Damage due to incorrect voltage or improper wiring.
- j. Any incidental, indirect, or consequential loss, damage or expense that may result from any defect, failure or malfunction of KATOOL Inc. product.
- k. Any equipment outside of the policy will not be covered and buyer will be responsible for purchasing replacement parts at full cost and shipping charges will apply.
- l. Labor is not included in warranty.

INSTALLER / OPERATOR PLEASE READ AND FULLY UNDERSTAND.

BY PROCEEDING YOU AGREE TO THE FOLLOWING:

- I have visually inspected the site where the lift is to be installed and verified the concrete to be in good condition and free of cracks or other defects.
- I Understand that installing a lift on cracked or defective concrete could cause lift failure resulting in personal injury or death.
- I understand that a level floor is required for proper installation and level lifting.
- I understand that I am responsible if my floor is of questionable slope and that I will be responsible for all charges related to pouring a new level concrete slab if required and any charges.
- I assume full responsibility for the concrete floor and condition thereof, now or later, where the above equipment model(s) are to be installed.
- Failure to follow danger, warning, and caution instructions may lead to serious personal injury or death to operator or bystander or damage to property.
- I understand that KATOOL lifts are designed to be installed in indoor locations only. Failure to follow installation instructions may lead to serious personal injury or death to operator or bystander or damage to property or lift.



Failure to follow danger, warning, and caution instructions may lead to serious personal injury or death to operator or bystander or damage to property.



Please read entire manual prior to installation. Do not operate this machine until you read and understand all the dangers, warnings and cautions in this manual.

INSTALLER / OPERATOR PROTECTIVE EQUIPMENT

Personal protective equipment helps makes installation and operation safer, however, it does not take the place of safe operating practices. Always wear durable work clothing during any installation and/or service activity. Shop aprons or shop coats may also be worn, however loose-fitting clothing should be avoided. Tight fitting leather gloves are recommended to protect technician hands when handling parts. Sturdy leather work shoes with steel toes and oil-resistant soles should be used by all service personnel to help prevent injury during typical installation and operation activities.

Eye protection is essential during installation and operation activities. Safety glasses with side shields, goggles, or face shields are acceptable. Everyday eyeglasses only have impact resistant lenses, they are not safety glasses.

Back belts provide support during lifting activities and are also helpful in providing worker protection. Consideration should also be given to the use of hearing protection if service activity is performed in an enclosed area, or if noise levels are high.

IMPORTANT SAFETY INSTRUCTIONS

Read these safety instructions entirely.

IMPORTANT NOTICE

Do not attempt to install this lift if you have never been trained on basic automotive lift installation procedures.

Never attempt to lift components without proper lifting tools such as forklift or cranes.

Stay clear of any moving parts that can fall and cause injury.

Read and understand all instructions and all safety warnings before operating lift.

The equipment can only be operated by qualified personnel trained to use this equipment. Misuse of the machine for other purpose or modifying any components of the equipment without receiving the permission from the manufacturer may result in direct or indirect damage to the equipment.

Due to the many variations in procedures, techniques, tools, and parts for changing tires as well as the skill and training of the individual performing the work, the manufacturer cannot anticipate any or all warnings necessary for the safe operation of the Tire Balancer. It is the technician's responsibility to be knowledgeable in the safe and acceptable means of changing tires on the wheels that are being serviced. Never endanger your safety, the safety of others in the work area or the equipment or vehicle being serviced.

1. Eye and face protection recommendations:
Protective eye and face equipment is required while using this equipment due to

potential of injury." O.S.H.A. 1910.133(a) Protective goggles, safety glasses, or a face shield must be provided by the owner and worn by the operator of the equipment. Care should be taken to see that all eye and face safety precautions are followed by the operator. ALWAYS WEAR SAFETY GLASSES. Everyday glasses only have impact resistant lenses, they are not safety glasses.

2. Read and understand this manual before operating. Abuse and misuse will shorten the functional life.
3. NEVER remove safety related components from the lift. Do not use lift if safety related components are missing or damaged.
4. STAY ALERT. Use common sense and watch what you are doing. Remember, SAFETY FIRST.
5. Only trained operators should operate this lift. All non-trained personnel should be kept away from the work area. Never let non-trained personnel come in contact with, or operate lift.
6. DO NOT override self-closing lift controls.
7. ALWAYS make sure the safeties are engaged before attempting to work on or near a vehicle.

8. **WARNING! RISK OF EXPLOSION.** This equipment has internal arcing or sparking parts which should not be exposed to flammable vapors. This machine should not be located in a recessed area or below floor level.



9. Check for damaged parts. Check for alignment of moving parts, breakage of parts or any condition that may affect operation of lift. Do not use lift if any component is broken or damaged.
10. Clear area if vehicle is in danger of falling.
11. KATOOL requires all operators to read and be familiar with ANSI/ALI ALIS Safety Requirements for Installation and Service of Automotive Lifts.
12. Guard against electric shock. This lift must be grounded while in use to protect operator from electric shock. Never connect the green power cord wire to a live terminal. This is for ground only.
13. **DANGER!** To reduce the risk of electric shock, do not use on wet surfaces or expose to rain. The Power Unit used on this lift contains high voltage. Disconnect power at the receptacle or at the circuit.
14. Care must be taken as burns can occur from touching hot parts.
15. Do not operate equipment with a damaged cord or if the equipment has been dropped or damaged until it has been examined and repaired by a qualified serviceman.
16. Do not let cord hang over edge of table, bench, or counter or come in contact with hot manifolds or moving fan blades.



17. If an extension cord is necessary, a cord with a current rating equal to or more than that of the equipment should be used. Cords rated for less current than the equipment may overheat. Care should be taken to arrange the cord so that it will not be tripped over or pulled.
18. Always unplug equipment from electrical outlet when not in use. Never use the cord to pull the plug from the outlet. Grasp plug and pull to disconnect.
19. Let equipment cool completely before putting away. Loop cord loosely around equipment when storing.
20. Keep guards and safety features in place and in working order.
21. Wear proper clothing. Safety toe, non-slip footwear and protective hair covering to contain hair is recommended. Do not wear jewelry, loose clothing, neckties, or gloves when operating the balancer.
22. Keep work area clean and well lighted. Cluttered and/or dark areas invite accidents.
23. Avoid dangerous environments. Do not use power tools or electrical equipment in a damp or wet environment, or expose them to rain.
24. Use only manufacturer's recommended accessories. Improper accessories may result in personal injury or property damage.

25. Repair or replace any part that is damaged or worn and that may cause unsafe balancer operation.
26. Do not operate damaged equipment until it has been examined and repaired by a qualified service technician.
27. To reduce the risk of fire, do not operate equipment in the vicinity of open containers or flammable liquids (gasoline).
- 28.
29. breaker switch before performing any electrical repairs. Secure plug so that it cannot be accidentally plugged-in during service. or mark circuit breaker switch so that it cannot be accidentally switched-on during service.
30. Adequate ventilation should be provided when working on or operating internal combustion engines.
31. Keep hair, loose clothing, fingers, and all parts of body away from moving parts.
32. Use equipment only as described in this manual.
33. Use only manufacturer's recommended attachments and accessories.
34. The equipment should be installed on the stable surface and not on a wooden pallet.
35. Do not install the equipment in a place with high temperature or moisture, near the heating system, water tap, air-humidifier or chimney.
36. Avoid contact with lots of dust, ammonia, alcohol, thinner or spraying binder.
37. People who are not operating the machines should be kept away during normal operation.
38. Pay special attention to the warning labels on the machine.
39. Do not touch or approach the moving parts by hand during operation.
40. Do not remove the safety device or prevent it from working properly.

SAVE AND FOLLOW THE ABOVE INSTRUCTIONS

Operator Protective Equipment:

Personal protective equipment helps make tire servicing safer. However, equipment does not take the place of safe operating practices. Always wear durable work clothing during tire service activity. Loose fitting clothing should be avoided. Tight fitting leather gloves are recommended to protect operator's hands when handling worn tires and wheels. Sturdy leather work shoes with steel toes and oil-resistant soles should be used by tire service personnel to help prevent injury in typical shop activities. Eye protection is essential during tire service activity. Safety glasses with side shields, goggles, or face shields are acceptable. Back belts provide support during lifting activities and are also helpful in providing operator protection. Consideration should also be given to the use of hearing protection if tire service activity is performed in an enclosed area, or if noise levels are high.

Definitions of Hazard Levels

Identify the hazard levels used in this manual with the following definitions and signal words:

DANGER

Watch for this symbol:



It Means: Immediate hazards, which will result in severe personal injury or death.

WARNING

Watch for this symbol:



It Means: Hazards or unsafe practices, which could result in severe personal injury or death.

CAUTION

Watch for this symbol:



It Means: Hazards or unsafe practices, which may result in minor personal injury or product or property damage.

BE ALERT

Watch for this symbol! It means BE ALERT! Your safety, or the safety of others, is involved!



Safety Notices and Decals



Failure to follow danger, warning, and caution instructions may lead to serious personal injury or death to operator or bystander or damage to property. Do not operate this machine until you read and understand all the dangers, warnings and cautions in this manual. For additional copies of either, or further information, contact:

Standard Safety Devices



Keep hair, loose clothing, fingers and all parts of body away from moving parts.

- Press STOP key for stopping the wheel under emergency conditions.

 **WARNING**

RISK OF EXPLOSION

This equipment has internal arcing or sparking parts which should not be exposed to flammable vapors. Do not locate in a recessed area or below floor level.

THIS EQUIPMENT MUST BE EARTH-GROUNDED

The earth-ground connector built into the power cord provides protection to reduce the risk of electrical shock.

 **AVERTISSEMENT**

RISQUE D'EXPLOSION

Cet équipement possède des pièces internes, pouvant lancer des arcs ou jeter des étincelles, et qui ne devraient pas être exposées à des vapeurs inflammables. Ne situez pas l'équipement dans des endroits encastrés ou en-dessous du niveau du plancher.

CET ÉQUIPEMENT DOIT ÊTRE MIS À LA TERRE

Le raccord de mise à la terre incorporé dans le cordon de puissance fournit une protection afin de réduire le risque d'électrocution.

 **CAUTION**

Do not use below garage floor or grade level.

Disconnect power before servicing this equipment.

To prevent electrical shock, do not remove cover. No user servicable parts inside. Refer servicing to qualified service personnel.

 **ATTENTION**

N'utilisez pas en-dessous du plancher du garage ou du palier.

Débranchez le cordon de puissance avant de faire l'entretien de cet équipement.

Afin de vous protéger contre l'électrocution, n'enlevez pas le couvercle. Aucune pièce interne ne nécessite d'entretien par l'utilisateur. Référez l'entretien à un personnel de service qualifié.

8113927 05

INTRODUCTION

Congratulations on the purchase of the KATOOL 2 Post Lift. This vehicle lift is designed for ease of operation, safe handling of vehicles. This equipment will provide many years of trouble-free operation requiring minimum maintenance and care. Please read this manual thoroughly before operating the unit. Instructions on use, maintenance and operational of the lift are covered in this manual.

1. Carefully remove the crating and packing materials. CAUTION! Use care when cutting steel banding material as items may become loose and fall, causing injury.

2. Check the voltage, phase, and proper amperage requirements for the motor shown on the motor plate. Wiring MUST be performed by a certified electrician only.

Owner's Responsibility

To maintain the lift and user safety, the responsibility Of the owner is to read and follow these instructions:

Follow all installation and operation instructions.

- Make sure installation conforms to all applicable Local, State, and Federal Codes, Rules, and Regulations; such as State and Federal OSHA Regulations and Electrical Codes.
- Carefully check the lift for correct initial function.
- Read and follow the safety instructions. Keep them readily available for machine operators.
- Make certain all operators are properly trained, know how to safely and correctly operate the unit, and are properly supervised.
- Allow unit operation only with all parts in place and operating safely.
- Carefully inspect the unit on a regular basis and perform all maintenance as required.
- Service and maintain the unit only with authorized or approved replacement parts.
- Keep all instructions permanently with the unit and all decals on the unit clean and visible.

Receiving:

The shipment should be thoroughly inspected as soon as it is received. The signed bill of lading is acknowledgement by the carrier of receipt in good condition of shipment covered by your invoice. If any of the goods called for on this bill of lading are shorted or damaged, do not accept them until the carrier makes a notation on the freight bill of the shorted or damaged goods. Do this for your own protection.

NOTIFY THE CARRIER AT ONCE if any hidden loss or damage is discovered after receipt and request the carrier to make an inspection. If the carrier will not do so, prepare a signed statement to the effect that you have notified the carrier (on a specific date) and that the carrier has failed to comply with your request.

IT IS DIFFICULT TO COLLECT FOR LOSS OR DAMAGE AFTER YOU HAVE GIVEN THE CARRIER A CLEAR RECEIPT. File your claim with the carrier promptly. Support your claim with copies of the bill of lading, freight bill,

invoice, and photographs, if available. Our willingness to assist in helping you process your claim does not make KATOOL responsible for collection of claims or replacement of lost or damaged materials.



Any other use is to be considered incorrect and unreasonable. The manufacture will not be responsible for any damage caused from misuse of this Tire Changer. Any use other than that specified in this manual is inappropriate, incorrect, and unreasonable.

KEEP THIS MANUAL NEAR THE MACHINE FOR FUTURE REFERENCE

Table of Contents

PRODUCT WARRANTY	2
Installer / Operator Instructions	4
Operator Protective Equipment	4
Important Safety Instructions	5
Definitions of Hazard Levels	8
Introduction	10
Table of content	12
1.0 Product Specifications:	13
1.1 Parts Inventory & Description:	17
1.2 Key Machine Components	18
1.2.1 Model Description	19
1.2.2 Purpose	19
1.2.3 Functions and Features	19
1.2.4 Technical Specifications	20
1.2.5 Basic parameters of the equipment	20
1.2.6 Environmental Requirements	20
2.0 Lift Structure	21
2.0.1 Main Structural Principles	23
3.0 Operation Description	24
3.0.1 Precautions for vehicle repair work	24
3.0.2 Preparation before operation	24
3.0.3 Inspection before operation	24
4.0 Lifting and Lowering the Vehicle:	25
4.0.1 How do I know if my vehicle is too heavy for a lift?	25
4.0.2 Lifting the Vehicle	26
4.0.3 Lowering the Vehicle	28
4.0.4 Manual Emergency Lowering	28
5.0 Hydraulic and Electrical System of the Equipment	29
5.0.1 Hydraulic System of the Lift:	29
5.0.2 The working principle of the hydraulic system	30
5.0.3 Electrical System of the Lift	31
5.0.4 The electrical working principle is as follows	31
6.0 Frequently Asked Questions (FAQ):	32
7.0 Repair and Maintenance	33
8.0 Maintenance of Hydraulic System	35
9.0 Storage and Scrap	36
10.0 Lift Set Up Instructions	37
10.0.1 Mechanical Installation	38
10.0.2 Electrical Installation	55
10.0.3 Lift Adjustment	56
10.0.4 Bleeding a 2-post lift (Without Bleeder Holes)	58
11.0 Safety Instructions	59
12.0 Sales and Tech Support Contact info	60



Failure to follow the instructions and safety precautions in this manual can result in serious injury or death. Make sure all other operators also read this manual. Keep the manual near the product for future reference. **By proceeding with setup and operation, you agree that you fully understand the proper use of this product and assume full responsibility of product use.**

1.0 Product Specifications

KT-M110 Two Post Clear-floor Vehicle Lift 11,000 lbs.

***Concrete thickness must be at least 5.9" (150 MM) with a 3000 PSI rating. Failure to install this lift on the proper concrete, could result in serious injury or death! It is the customer's responsibility to verify concrete thickness and strength before purchase and installation.**

- 11000lbs lifting capacity
- CE Approved and Certified. It has adopted the 115% dynamic loading capacity standard and was 150% static loading capacity tested
- Symmetric clear-floor design
- Manual safety release from two sides
- Symmetric arm
- Dual Hydraulic Chain-Drive Cylinders
- Rubber pad door opening protection
- Comes with extension support adaptor sets of +30mm and +120mm
- Added overhead safety shutoff bar
- Feet-protection safety guardrails with tools box
- High-quality hydraulic system with 220V/60HZ/1PH (110V/60HZ/1PH OPTIONAL ADD-ON PURCHASE \$199)



Figure 1.

Lifting Capacity	11000lbs.(5000KG)
Max. Lifting Height	70.75"/1800mm
Min. Height	4.25"/110mm
Height Overall	141.25"/3587mm
Width Overall	142.25"/3614mm
Outside Column	128"/3250mm
Inside Column	110.25"/2800mm
Drive-Thru Clearance	94.5"/2400mm
Front Arm Reach (Min)	30.75"/780mm (2 stages)
Front Arm Reach (Max)	50.5"/1280mm (2 stages)
Rear Arm Reach (Min)	30.75"/780mm (2 stages)
Rear Arm Reach (Max)	50.5"/1280mm (2 stages)
Motor	220VAC/60HZ/1PH/2.2KW
Net Weight	1389lbs/630KG

KT-M120 Two Post Clear-floor Vehicle Lift 12,000 lbs.

***Concrete thickness must be at least 5.9" (150 MM) with a 3000 PSI rating. Failure to install this lift on the proper concrete, could result in serious injury or death! It is the customer's responsibility to verify concrete thickness and strength before purchase and installation.**

- 12000lbs(5500KG) lifting capacity
- CE Approved and Certified. It has adopted the 115% dynamic loading capacity standard and was 150% static loading capacity tested
- Manual safety release from two sides
- Symmetric arms
- Dual Hydraulic Chain-Drive Cylinders
- Rubber pad door opening protection
- Comes with extended support adaptor sets of + 30 mm and + 120 mm
- Overhead safety shutoff bar
- Feet-protection safety guardrails with tools box
- High-quality hydraulic system with 220V/60HZ/1PH (110V/60HZ/1PH OPTIONAL ADD-ON PURCHASE \$199)



Figure 2.

Lifting Capacity	12000 lbs. (5500KG)
Max. Lifting Height	70.75"/1800mm
Min. Height	4.25" / 110mm
Height Overall	166.75" / 4235mm
Width Overall	165.5" / 4204mm
Outside Column	151.25" / 3840mm
Inside Column	130" / 3390mm
Drive-Thru Clearance	117.75" / 2990mm
Front Arm Reach (Min)	34.75"/880mm (2 stages)
Front Arm Reach (Max)	65"/1650mm (2 stages)
Rear Arm Reach (Min)	34.75"/880mm (2 stages)
Rear Arm Reach (Max)	65"/1650mm (2 stages)
Motor	220VAC/60HZ/1PH/2.2KW
Net Weight	1786lbs/810KG

1.1 Parts Inventory & Description

Be sure to take a complete inventory of parts prior to beginning installation.

Description	QTY
Overhead Assembly	1
Lift Arm Assemblies	4
Frame Contact Pads	4
Offside Post	1
Powerside Post	1
Post Extension Weldments	2
Hydraulic Cylinders	2
Parts Box	1
Hydraulic Power Unit	1

Figure 3.

1.2 Key Machine Components:

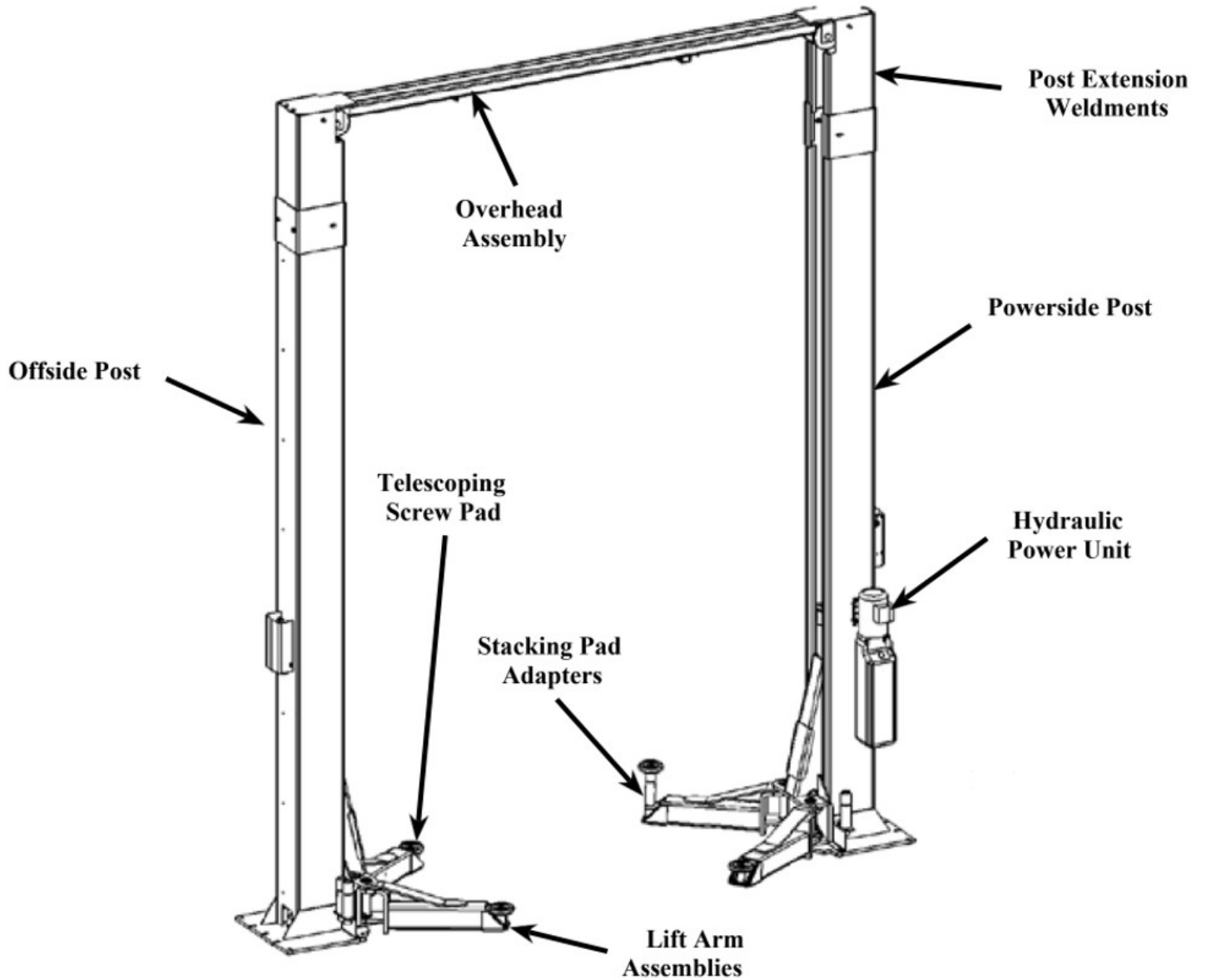

M110/M120

Figure 4.

Outline:

1.2.1 Model Description:

Model	Description
KT-M110 2-Post Lift with cross beam	11000lbs, Symmetric 2-post lift with cross beam (Fig.1)
KT-M120 2-Post Lift with cross beam	12000lbs, Symmetric 2-post lift with cross beam (Fig.2)

1.2.2 Purpose

This machine is applicable for the lifting of various small and medium-sized vehicles with total weight 10000lbs or 11000lbs in garage and workshop.

1.2.3 Functions and Features

- All cable and oil lines are fully concealed for elegant appearance.
- The equipment is designed based on international standards, meeting the needs of automotive garages and workshops.
- Top limit switch, effectively protects the vehicle from overhead damage.
- Stable lifting and lowering of vehicle is provided by a dual hydraulic cylinder drive system.
- Manual lowering of the vehicle is achieved with a safe and simple operation system.
- A dual cable system provides a synchronous, balanced force to the two carriages to effectively prevent the vehicle from tilting.
- 110mm Lowest height lift pads good for repairing low chassis or low-profile car.

1.2.4 Technical Specifications

Noise: Working noise: $\leq 75\text{dB(A)}$

Power unit: Electrical parameters of the machine: Motor (optional)

Voltage: According to client's requirement

Single phase: 110V/60Hz 2.2kW, 220V/50Hz 2.2 kW, 200V/60Hz 2.2 kW

Three phases: 380V/50Hz 2.2 kW

1.2.5 Basic parameters of the equipment:

Model	Rated Load (lbs.)	Lifting Height (in/mm)	Raising Time (sec)	Decent Time (sec)	Net Weight (lbs./kg)	Width between Columns (in/mm)	Machine Width (in/mm)	Machine Height (in/mm)
KT-M110	11000 lbs. (5000 kg)	70.75" (1800mm)	$\leq 50\text{s}$	$\geq 20\text{s}$	1389lbs. (630 kg)	110.23" (2800mm)	142.25" (3614 mm)	141.25" (3587 mm)
KT-M120	12000 lbs. (5500 kg)	70.75" (1800mm)	$\leq 50\text{s}$	$\geq 20\text{s}$	1786lbs. (810Kg)	130" (3390mm)	165.5" (4204mm)	166.75" (4235mm)

1.2.6 Environmental Requirements:

Working temperature: $-50^{\circ}\text{C} \sim 40^{\circ}\text{C}$

Relative humidity: 80% @ 30°C

Transport/storage temperature: $-5^{\circ}\text{C} \sim +400^{\circ}\text{C}$

Height above sea level: 2000m max

2.0 Lift Structure

Lift structures are shown as below:

Model	Description
KT-M110 2-Post Lift with cross beam	11000lbs, Symmetric 2-post lift with cross beam (Fig.5)
KT-M120 2-Post Lift with cross beam	12000lbs, Symmetric 2-post lift with cross beam (Fig.6)

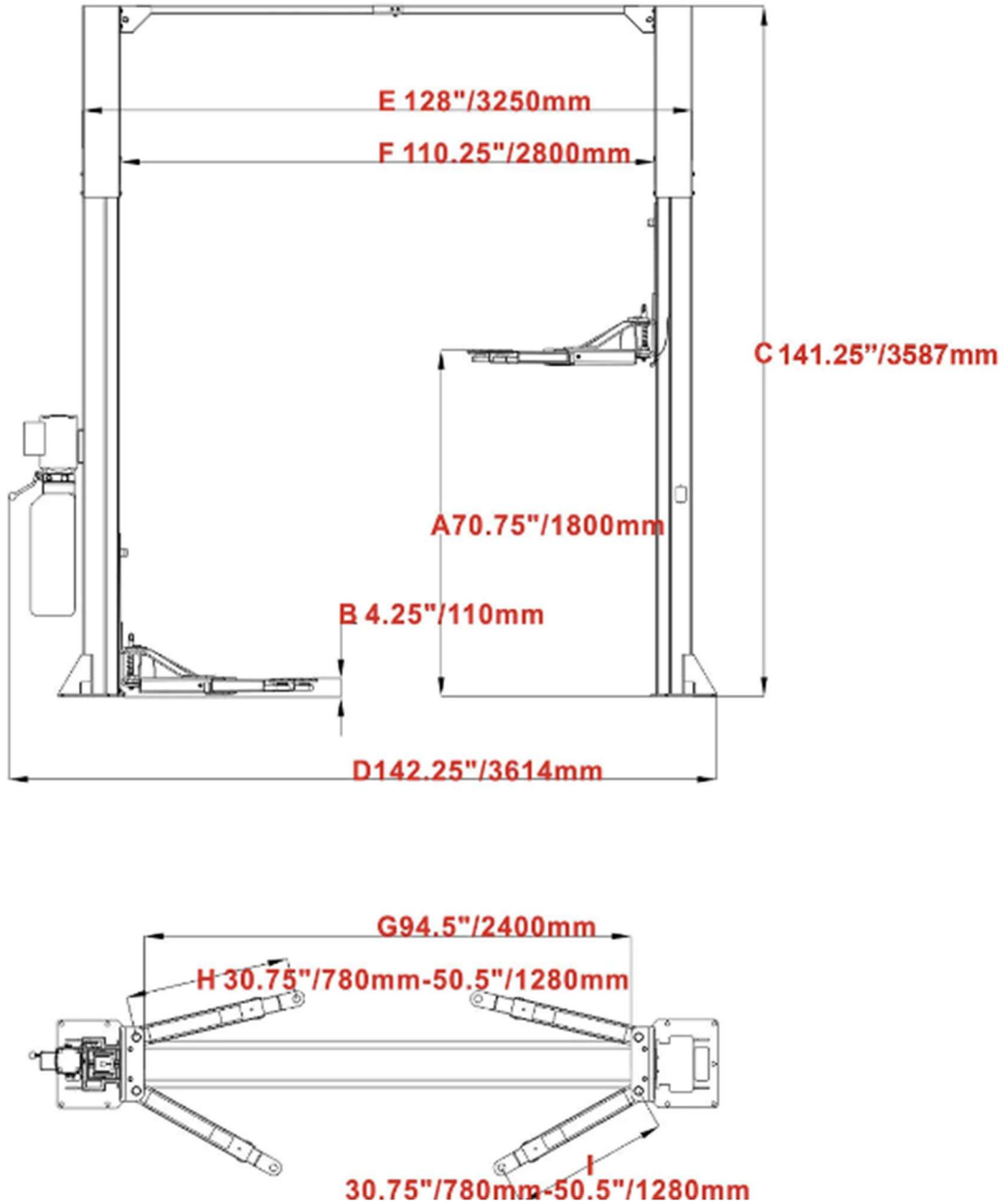

Figure. 5: KT-M110 2-Post Lift with cross beam

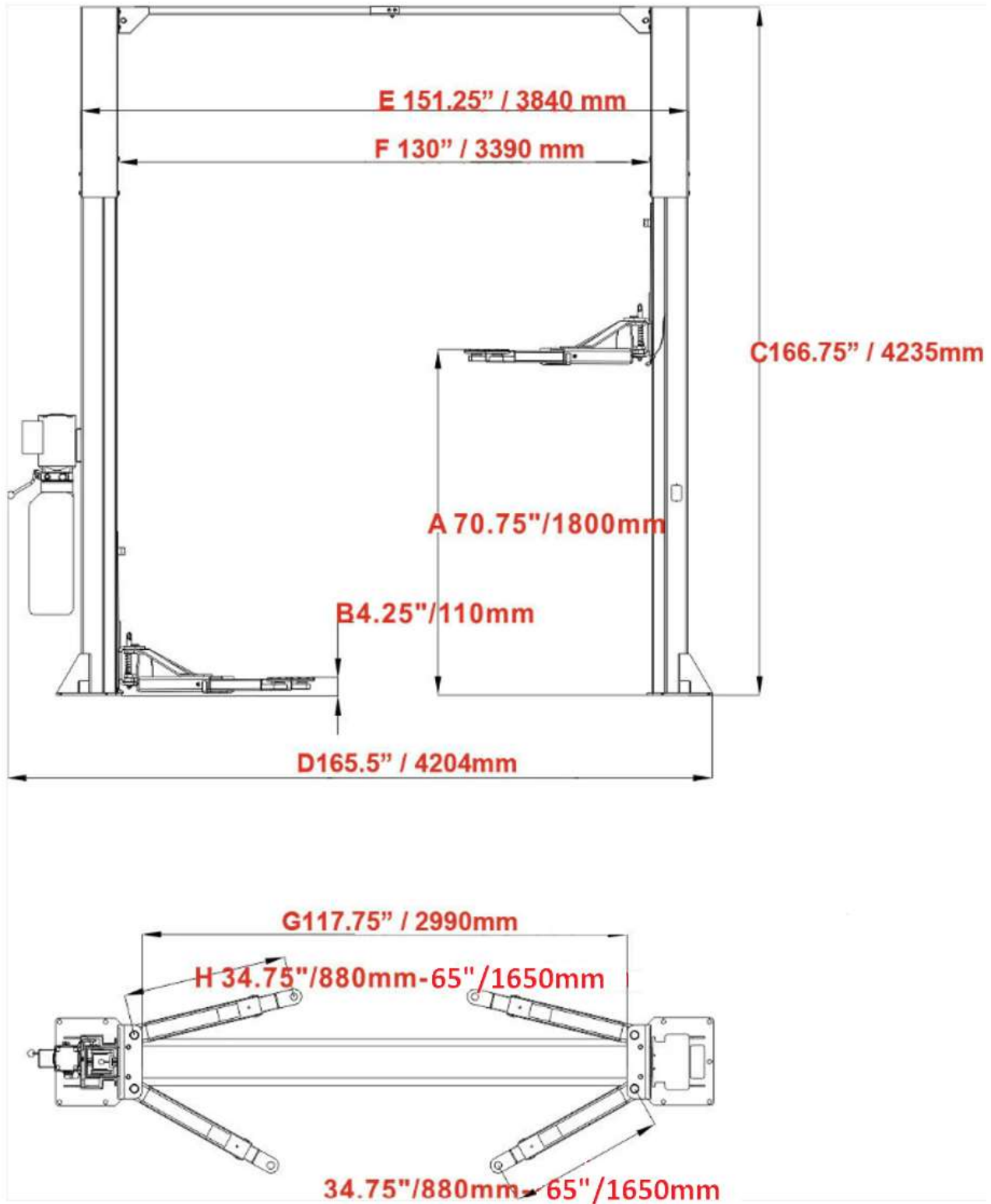

Figure. 6: KT-M120 2-Post Lift with cross beam

2.0.1 Main Structural Principles:

Lifting mechanism: Each column is installed with a hydraulic cylinder. When hydraulic oil is pressed from power pack into the lower chamber of main cylinder, the piston rod moves upwards to drive the upward movement of carriage via leaf chain.

Load supporting mechanism: When vehicle drives into the working area, adjust the angle and telescopic length of arms to align the lifting pads to the load bearing support point of the vehicle as described in the vehicle's operator's manual, then adjust the lower screw's height of lifting pad to adjust for vehicles with different chassis heights.

Balance mechanism: In order to keep machine balanced during lifting and lowering; the two carriages are interconnected and forced to move synchronously by two cables. If the right and left carriages and arms are not at the same level, adjust the end nut of cable and pull wire ropes tight to make arms leveled.

Manual safety locking system: There are safety locking plates installed on the two carriages and a toothed bar plate is welded on the internal wall of the column. During the lifting of the carriage, the safety locking plate goes up against the toothed bar plate by the tension of spring. When the carriage stops, the safety locking plate opens and then engages in the toothed bar slot to lock the carriage in position and prevents it from falling down. When the lowering operation is required, raise the carriage upward a little to loosen the safety locking plate from the toothed bar slot. Next, manually pull the steel wire rope to lift up the safety locking plate from the sliding plate. This will disengage the safety lock to allow lowering of the carriage. The lift incorporates a safety locking system that provides a dual safety protection since the manual pull mechanisms are installed on the both carriages. Therefore, to engage the safety locking system, the steel rope on the two carriages must be pulled respectively. To prevent the vehicle from slipping, the swing arm is installed with positioning mechanism. This mechanism automatically locks the swing arm during operation.

Safety lock scope: Safety lock mechanism is effective when the front end of carriage is between 450 mm and 1900mm high above the ground.

3.0 Operation Description

3.0.1 Precautions for vehicle repair work

- Different vehicles have different center of gravity positions. It is important to understand the position of center of gravity of the vehicle being serviced. When vehicle enters into the lift, make sure to align its center of gravity close to the vertical plane formed by the two columns. Adjust the swing arm, and align the lifting pad support to the lifting point of the vehicle.
- For vehicle lifts with cross beam, pay attention to the roof of the car to prevent accidental impact with the cross beam during lifting operation.
- Carefully read all warning labels.
- The hydraulic valves have been factory calibrated, and the user can't make self-adjustment, otherwise the user will be responsible all consequences.
- Some specifications in the instruction manual are subjected to change without notice depending on production needs.

3.0.2 Preparation before operation

- Lubricate contact surface of the carriage with general-purpose lithium grease (GB7324-87).
- All sliding surface should be coated evenly from the top to bottom.
- Fill hydraulic oil N32 or N46 to the oil reservoir of the power unit.

3.0.3 Inspection before operation

- Check to see if the motor power is installed properly.
- Check to see if all the connection bolts are fastened.

WARNING

Note: Don't operate the lift with damaged cables or damaged and missing parts. The lift should only be operated after it is repaired and inspected by a qualified professional repair technician.

4.0 Lifting and Lowering the Vehicle:

4.0.1 How do I know if my vehicle is too heavy for a lift?



Two-post lifts generally have weight capacities ranging from 7,000 to 20,000 pounds, accommodating various vehicles from light-duty cars to heavy-duty trucks. It's important to note that each lift arm also has its own weight limit. For instance, a lift with a 10,000-pound total capacity may have each arm rated for 2,500 pounds. Therefore, if a vehicle's weight distribution exceeds this per-arm limit, the lift may not be suitable.

Calculating Required Lift Capacity

To determine the appropriate lift capacity:

- 1) **Calculate Rear Axle Weight:** Multiply the vehicle's total weight by the distance from the center of gravity to the front axle, then divide by the wheelbase.
- 2) **Calculate Front Axle Weight:** Subtract the rear axle weight from the total vehicle weight.
- 3) **Determine Arm Capacity:** Divide each axle's weight by two to find the load per arm.

For example, if a vehicle weighs 9,000 pounds with a 3,000-pound front axle and a 6,000-pound rear axle, each arm would need to support 3,000 pounds. In this case, a 10,000-pound lift with 2,500-pound arms would be insufficient. Opting for a 12,000-pound lift would be safer.

Importance of Choosing a Lift with Adequate Capacity

Selecting a lift with a capacity that exceeds the vehicle's weight requirements is advisable. This accounts for variables like vehicle modifications, additional equipment, or unexpected weight distributions. Many manufacturers recommend not exceeding 75% of a lift's rated capacity to maintain safety margins.

Safe Operating Practices

- Adhere to Weight Limits: Never exceed the lift's total or per-arm weight capacities.
- Proper Vehicle Positioning: Ensure the vehicle is centered and balanced on the lift to distribute weight evenly.
- Regular Maintenance: Follow the manufacturer's maintenance schedule and conduct routine inspections to identify potential issues.

By understanding and respecting the weight capacities and operational guidelines of two-post lifts, automotive shops can ensure safer working conditions and prolong the lifespan of their equipment.

4.0.2 Lifting the Vehicle

- Keep work area clean, don't operate the lift in cluttered work area.
 - Lower the carriage to the lowest position by pressing the lowering handle at the power unit.
 - Swing arms will release as soon as the carriage touches the floor.
 - Reduce the swing arms to the minimum length.
 - Swing the arm out of the way of the vehicle path.
 - Move the vehicle to the location between the two columns.
 - Swing the arms and put the lifting pad below the recommended vehicle lift point, and adjust the height of lifting pad to touch lift point of the vehicle.
 - Press the UP button on the electric control box to slowly lift the vehicle to ensure the load balance, and then raise the lift to the required height.
 - Lift will stop once the UP button is released or upward travel limit is reached.
 - Press the lever to lower the vehicle to engage the safety lock of carriage. At this time, the vehicle can be repaired.
- ⚠️ WARNING** *Never unlatch the arm restraints when the lift is under load.*
- Do not allow unauthorized persons to stay under the raised vehicle.
 - Avoid rocking of vehicle.
 - Keep lift free of tools, parts, etc.

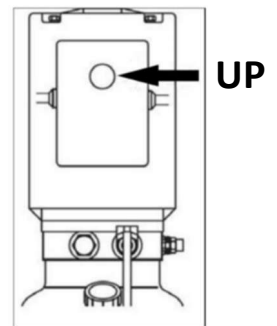
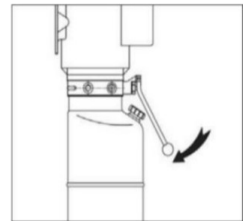

- Fasten the vehicle to the support arms using lashing straps when removing or installing heavy components.

CAUTION

Note:

- ***Before operation, the safety locking devices must be Inspected.***
 - 1) ***The gear blocks of the arm end must engage the gear block of the restraint shaft.***
 - 2) ***Inspect the steel cable for broken strands.***
 - 3) ***Inspect the lift pads for any deformation.***
- ***When lifting the vehicle, all four swing arms must be used.***
- ***Before lifting the vehicle, check all the hydraulic hose and fittings for oil leakage. In case of leakage, please don't use the lift. Remove the fitting with leakage. Re-install the fitting and check if oil leakage still exists. Replace with a new fitting if the oil leak does not stop.***
- ***After the vehicle is lifted, when adding or removing any major heavy object, use a jack stand to maintain the balance of the vehicle.***

WARNING

- ***Always lock the lift before going under the vehicle.***
- ***Never allow anyone to go under the lift when raising or lowering. Read the safety procedures in the manual.***
- ***During raising and lowering cycles: Closely watch the vehicle and the lift, do not allow anyone to stay in the lift area and make sure the vehicle doors are closed.***
- ***Always make sure safety latches on both sides clear the rack at same time when pulling down the release handle by adjusting the cable.***

4.0.3 Lowering the Vehicle

- Clean the work area before lowering the vehicle.
- Stay clear of the vehicle before lowering the vehicle.
- First press the UP button to rise the vehicle a little, then pull two steel ropes on two carriages to disengage the safety lock.



Lowering Handle

- Press the lowering handle to lower the vehicle.
- Lower the vehicle till the swing arm reaches its lowest position and the lifting pads disengage from the vehicle chassis.
- Then release the lowering handle.
- Move the swing arms out of the way from under the vehicle.

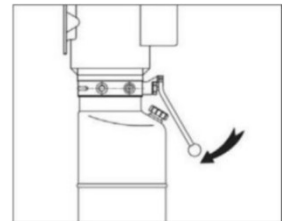

4.0.4 Manual Emergency Lowering

- In case of no electric power or power unit failure, lower the loaded vehicle manually to its initial position as follows:
- Lockout tag out the power switch.
- If the mechanical safeties are engaged, raise the lift a little by using a hydraulic jack or the emergency hand pump (optional), then pull two steel ropes on two carriages to disengage the safety lock.
- Press the lowering handle to lower the vehicle.



Note:

- ***In case of loss of function, you must switch off the power.***

5.0 Hydraulic and Electrical System of the Equipment:

5.0.1 Hydraulic System of the Lift

Diagram of the hydraulic system of cross beam 2-Postlift

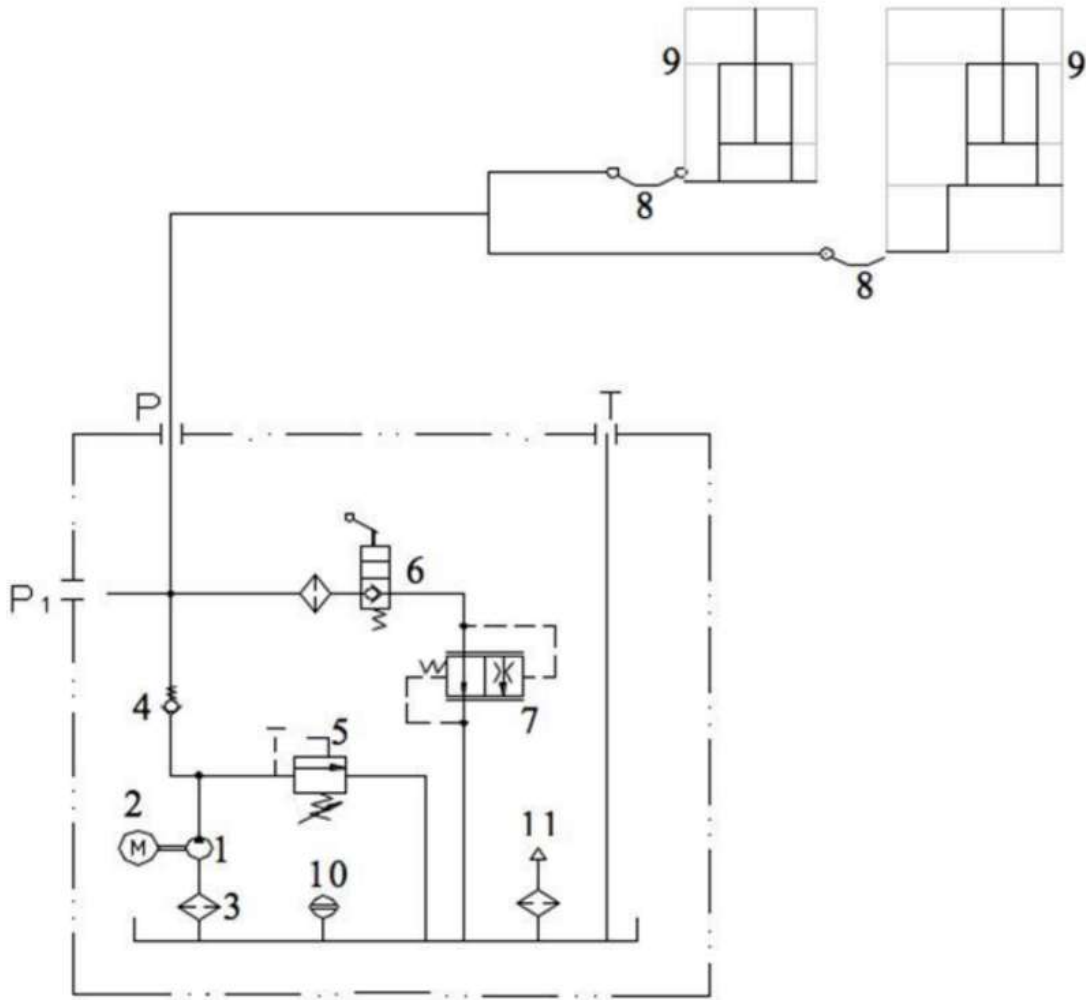

- 1- Gear pump, 2-Motor, 3-Oil filter, 4- Check-valve, 5- Safety valve, 6- Lowering handle valve, 7- Servo flow-control valve, 8- Hose, 9- Hydraulic cylinder, 10- Level gauge, 11- Air filter

Figure. 7

5.0.2 The working principle of the hydraulic system is as follows:

- As shown in above figure 7, when the start button is pressed, the motor (2) is started, driving the oil pump (1), sucking the hydraulic oil from the oil tank into the oil cylinder (9), forcing the piston rod to move. At this time, the safety valve (5) is closed.
- (The safety valve controls the pressure in the system for the rated load, but when the pressure in the system exceeds the limit, the safety valve will overflow automatically to protect the hydraulic system).
- Release the start button to stop the oil supply and the lifting will stop. For lowering; first start Motor (2) to raise vehicle a little, pull the steel ropes on two carriages to release the safety lock mechanism, then press the lowering handle, the valve (6) is actuated, the hydraulic oil flows back and the lift starts lowering.

5.0.3 Electrical System of the Lift:

Diagram of electrical system for single phase motor

M1-Motor KM-Contactor
SB –Button
SQ- Limit switch

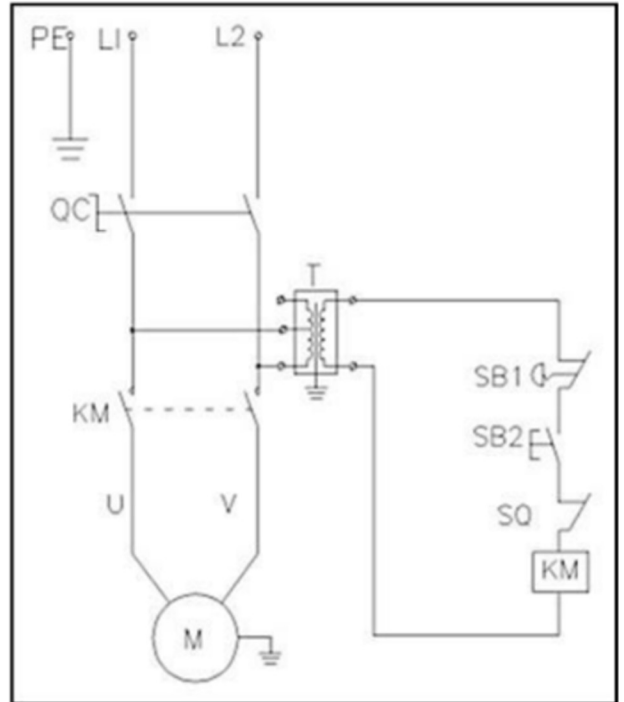

Figure. 8

5.0.4 The electrical working principle is as follows:

When the start button (SB) is pressed, the contactor (KM) will be powered; motor (M) is energized to drive the gear pump supplying oil to push the carriage upward.

When the start button is released, the contactor (KM) opens, the motor (M) will lose the power, to stop the raising of the carriage. As for the cross-beam lift, if the vehicle is lifted up to the top and contacts the limit switch on the top beam, the contactor (KM) will open, then the motor (M) will lose the power, to stop the carriage.

6.0 Frequently Asked Questions (FAQ):

Symptom	Reason	Solution
Motor not operation	<ul style="list-style-type: none"> • Check the circuit breaker or thermal relay for tripping • Check the voltage to the motor • Check the electrical wiring • Limit switch is failed • Motor wire is burnt 	<ul style="list-style-type: none"> • Close the switch of circuit breaker or press the blue reset key of thermal relay • Supply correct voltage for motor • Correctly wiring as electrical system diagram • Replace the limit switch • Replace the motor
Motor is running, but the lift can't be raised.	<ul style="list-style-type: none"> • Motor rotation reversed • Lowering valve body open. • Hydraulic pump sucks the air • Suction tube is separate from the hydraulic pump. • Low oil level 	<ul style="list-style-type: none"> • Change the motor rotating direction through changing wire connection. • Repair or replace the lowering valve Body • Fasten all the suction pipe fittings • Replace the suction tube • Add the oil into the oil tank
Motor is running, the lift can be raised without load, but the vehicle can't be raised	<ul style="list-style-type: none"> • Motor is running under low voltage • Impurities inside the lowering valve body • Regulation pressure of safety valve is incorrect. • Lift is overloaded 	<ul style="list-style-type: none"> • Supply correct voltage to the motor • Remove impurities from the lowering valve body. • Adjust the safety valve • Check the weight of the vehicle
The lift is lowering slowly without pressing the lowering handle	<ul style="list-style-type: none"> • Impurities on the lowering valve body. • External oil leakage 	<ul style="list-style-type: none"> • Clean the solenoid valve body • Repair the external leakage
The lifting speed is slow or oil flows out of the oil fill cap	<ul style="list-style-type: none"> • Air and oil are mixed • Air and oil suction are mixed • Oil return pipe is loosened 	<ul style="list-style-type: none"> • Replace the hydraulic oil • Fasten all the suction pipe fittings • Re-install the oil return pipe
The lift can't rise horizontally	<ul style="list-style-type: none"> • Balance cable is not adjusted properly • The lift is installed on the slop floor 	<ul style="list-style-type: none"> • Adjust the balance cable to the proper tension • Shimming the columns to level the lift (no more than 5mm), If exceeding 5mm, pour new concrete floor and make it leveled. Refer to installation description.
Anchor Bolt is not fastened	<ul style="list-style-type: none"> • Hole is drilled too big • Concrete floor thickness or fastening force is insufficient . 	<ul style="list-style-type: none"> • Pour the fast curing concrete into the big hole and re-install the anchor Bolt , or use new drill to drill the hole for re-positioning the lift • Cut open the old concrete and make new concrete slab for the lift. Refer to installation description.



If the problems remain unsolved, call for technical support.

7.0 Repair and Maintenance

Cleaning:

- The lift should be cleaned with dry cloth frequently. Switch off the power before cleaning, to ensure safety.
- The working environment of this unit should be clean.
- Excessive dust in the working environment, will speed up the wear of the parts and shorten the service life of the lift.

Every day:

- Before the operation, carefully check the safety mechanism of the lift to ensure the electromagnet suction and release action is proper, and the safety plate is in good condition.
- When finding any abnormal situation, make sure to repair or replace the failed components immediately.
- Check to see if the steel cable connection is proper, and if the tension is at the optimum status.
- Check to see if the connection between hydraulic cylinder and carriage shows no damage, and make sure that the connecting nut between the steel chain and carriage is not lose or falling.

Every day:

- Tighten all anchor bolts.
- Lubricate chains/cables.
- Check all the chain connectors, bolts and pins to ensure correct installation.
- Check all the hydraulic lines for wear or leaks.
- Check to see if the carriage and the inner side of the column are properly lubricated. Use high-quality heavy lubrication grease (Lithium based lubrication grease GB7324-87).

WARNING

Note: All the anchor Bolt s should be tightened and secured completely. If any screw is loose, the lift cannot be used until the bolt is replaced or tightened.

Every six months:

- Check all the movable parts for possible wear, interference or damage.
- Check the lubrication of all the pulleys. If the pulley is dragging during the lifting and lowering operation, add appropriate lubricant to the wheel axle.
- When necessary, check and adjust the balancing tension to ensure a horizontal lift and lowering of the carriage.
- Always ensure that the columns are vertical and not tilted.



Note: The inside walls of each column should be lubricated with lubricant, to minimize the roller friction and ensure smooth and even lifting.

8.0 Maintenance of Hydraulic System:

- Make sure to change the oil 6-months after initial use of the lift unit. When performing the 6-month service, make sure to clean the hydraulic oil tank.
- Later clean the hydraulic system once a year, and replace the oil.
- Replace the seal After this unit is put into operation for certain period of time.
- If an oil leakage is found, carefully look for the source of the leak; if the leakage is due to the worn seals, immediately replace the seals.

Diagram of hydraulic line of cross beam 2-post lift

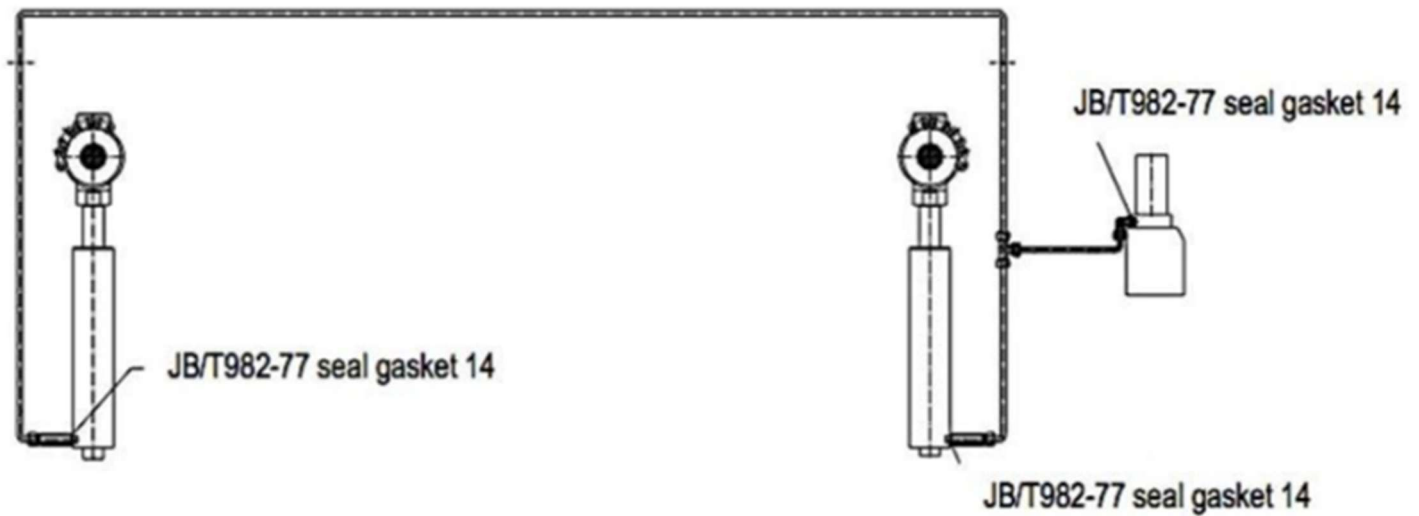

Figure. 9

9.0 Storage and Scrap:

9.0.1 Storage

When the equipment requires long-time storage:

- Disconnect the power supply
- Lubricate all the parts requiring lubrication: mobile contact surface of the carriage, etc.
- Empty all the oil/liquid storage units
- Put the plastic cover over the equipment for dust protection.

9.0.2 Scrap

When the equipment service life is expired and can no longer be used, disconnect the power supply, and properly dispose of as per relevant local regulations.

10.0 Lift Set Up Instructions

IMPORTANT NOTICE

These instructions must be followed to ensure proper installation and operation of your lift. Failure to comply with these instructions can result in serious bodily harm and void product warranty. Manufacturer will assume no liability for loss or damage of any kind, expressed or implied resulting from improper installation or use of this product.

PLEASE READ ENTIRE MANUAL PRIOR TO INSTALLATION

Selecting Site Notice

Before installing your new lift, check the following.

- LIFT LOCATION:** Always use architects plans when available. Check layout dimension against floor plan requirements making sure that adequate space is available.
- OVERHEAD OBSTRUCTIONS:** The area where the lift will be located should be free of overhead obstructions such as heaters, building supports, electrical lines etc.
- DEFECTIVE FLOOR:** Visually inspect the site where the lift is to be installed and check for cracked or defective concrete.



- OPERATING TEMPERATURE.** Operate lift only between temperatures of 41° -104° F.
- Lift is designed for **INDOOR INSTALLATION ONLY**. Outdoor use is prohibited.

Floor Requirements



This lift must be installed on a solid level concrete floor with no more than 3-degrees of slope. Failure to do so could cause personal injury or death.



When removing the Lift from shipping angles, pay close attention as the Posts can slide and can cause injury. Prior to removing the Bolts, make sure the Posts are held securely by a Forklift, Shop Crane, or some other heavy lifting device.

A level floor is suggested for proper use and installation and level lifting. If a floor is of questionable slope, consider a survey of the site and/or the possibility of pouring a new level concrete slab.



- DO NOT** install or use this lift on any asphalt surface or any surface other than concrete.
- DO NOT** install or use this lift on expansion seams or on cracked or defective concrete.
- DO NOT** install or use this lift on a second / elevated floor without first consulting building architect.

CONCRETE SPECIFICATIONS

LIFT MODEL	CONCRETE REQUIREMENTS
11,000 Lb Models:	5.9" Min. Thickness 3,000 PSI
10,000 Lb Models:	5.9" Min. Thickness 3,000 PSI
10,000 Lb Models:	5.9" Min. Thickness 3,000 PSI



All models **MUST** be installed on 3,000 PSI concrete only, conforming to the minimum requirements shown above. New concrete must be adequately cured for 28 days.

10.0.1 Mechanical installation

Tools for Installation and Adjustment

To ensure proper installation and adjustment, please prepare the following tools:

Tool	Model
Leveling instrument	Carpentry type
Chalk line	Min 177.17” (4.5m)
Hammer	1.5kg
Medium crescent wrench	1.57” (40mm)
Open-end wrench set	0.43”-0.91” (11mm-23mm)
Ratchet socket set	
Flat Screw driver	5.91” (150mm)
Rotary hammer drill	0.75” (19mm)
Concrete drill-bit	∅ 0.75” (19mm)

Unpacking

- Disassemble the posts from the packing support bracket by removing the screws marked by arrows below.
- Remove the packing materials and inspect the lift for any sign of shipment damage. Check the packing list to see if the main parts and accessories are complete.
- Keep the packing materials away from the children to avoid injury; dispose off any packing materials in a safe and proper manner.
- Layout everything on the floor and inspect everything.

Support the top column with the fork lift while disassembling the posts from the packing support bracket



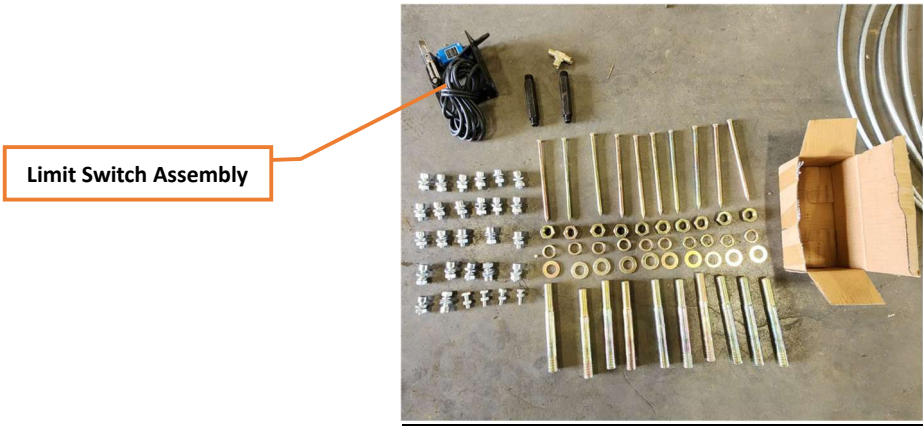
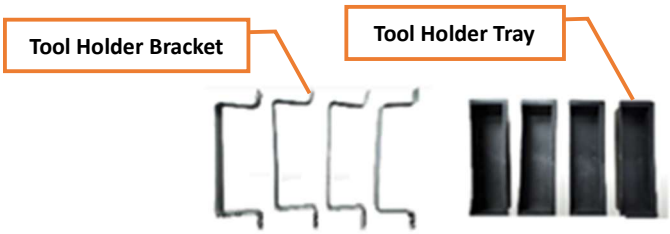

Important notice:



- Incorrect installation of the lift system can cause damage to the lift or personal injury.
- The manufacturer will not take any responsibilities for any damage caused due to incorrect installation and usage of this equipment, directly or indirectly.
- The correct installation location shall be flat horizontal floor to ensure a proper horizontal lift.
- A lift system installed on a slightly sloped floor can be levelled by proper shimming. Any large slope will affect the height of the lifting pad when at the bottom or the maximum lift height.
- If the floor is of questionable slope, consider a visual inspection, or pour a new horizontal concrete slab if possible.
- In short, the level of the lift relies on the level of the floor where it is installed.
- Do not install the lift on a grade that has a giant slope.

Installation site:



Select installation site based on the following conditions:

- Lift can only be installed on concrete slab, which must have a minimum thickness of 5.9” (150 MM) with a 3000 PSI rating or more and should be aged at least 7 days.
- Don’t install the lift on any asphalt surface or any surface other than concrete.
- The concrete slab should be reinforced using steel bar.
- The concrete slab must be level.
- Check for possible obstruction, e.g. low ceiling height, wireways, conduits, overhead pipeline, walkways, exits, etc.
- The front and back of the lift should be reserved with sufficient space to accommodate all the vehicles (Fig. 10).
(evaluating from the center line, max cantilever should be about 4m)

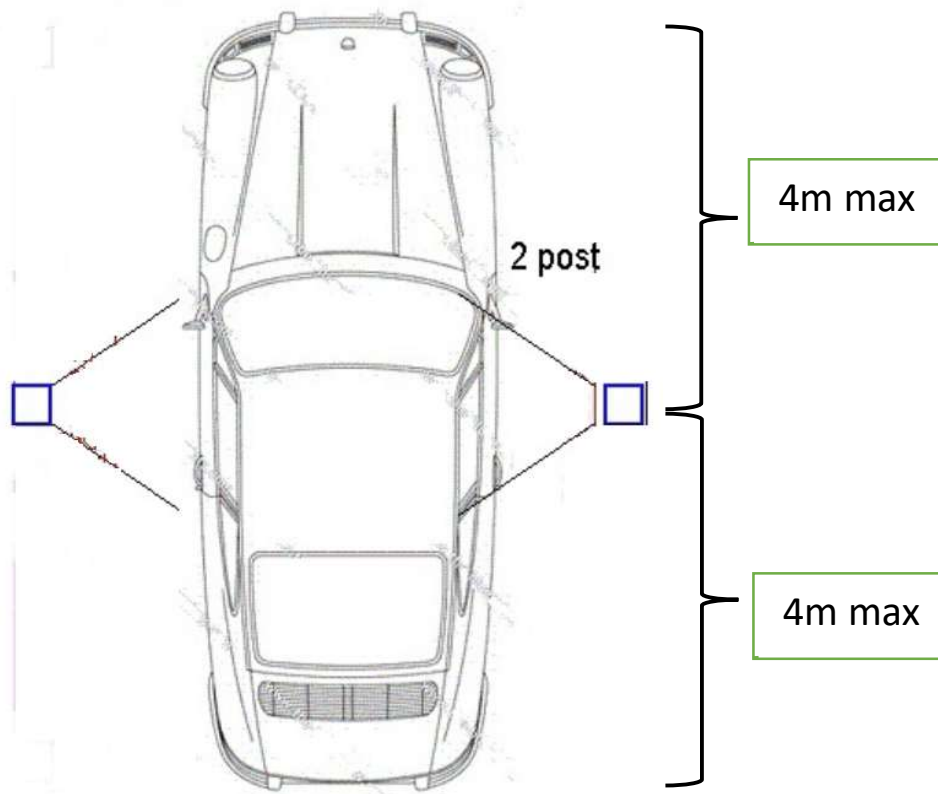

Figure 10

- Don't install the lift on the concrete with seams or cracks and defects.

⚠ CAUTION

- Make sure to get the post installation inspected and certified by an architect.
- Without the written approval of the architect, don't install the lift on a second

⚠ CAUTION

floor with basement.

- Overhead obstruction: The lift installation area can't have any overhead obstruction, such as heater, building
- Overhead obstruction: The lift installation area can't have any overhead obstruction, such as heater, building support, electrical pipe, etc.
- When selecting the location for the lift make sure there is enough ceiling clearance. Use the figure below to establish minimum ceiling height.

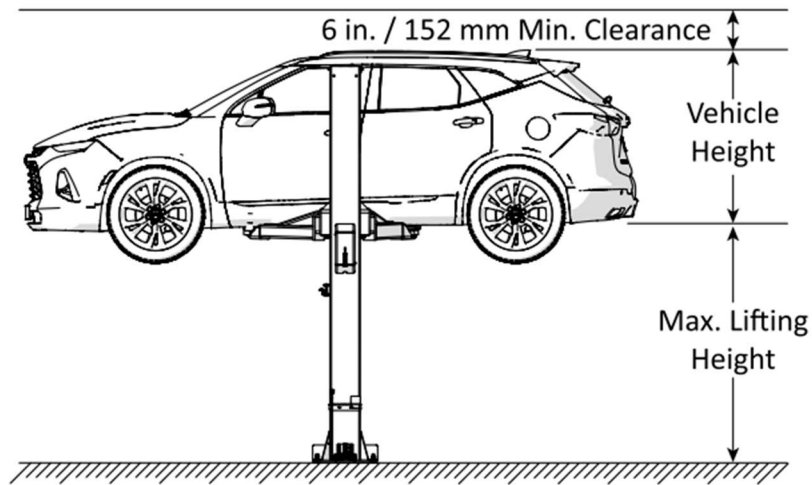

Figure 11

- Concrete drilling test: The installation personnel can test the concrete strength by performing the concrete drilling test. If several lifts are installed at one place, it is preferred to complete a drilling test on each site.
- Power supply: Make sure to get a dedicated power line installed by a certified electrician

Base frame layout:

Shown below are the Base frame layouts for M110 and M120 Lifts. Make to use the correct layout for your corresponding 2 Post Lift model.

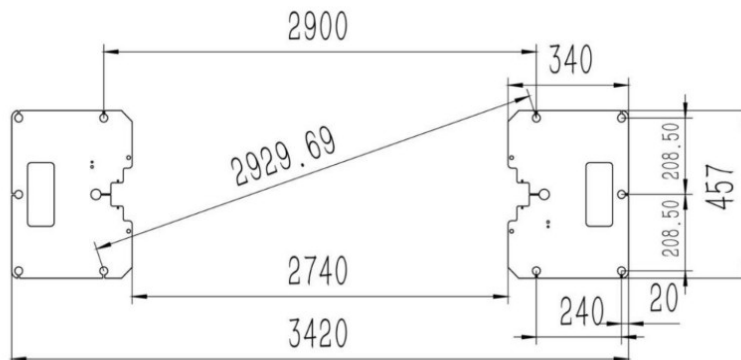

Figure 12a **Frame layout for M110 Lift**

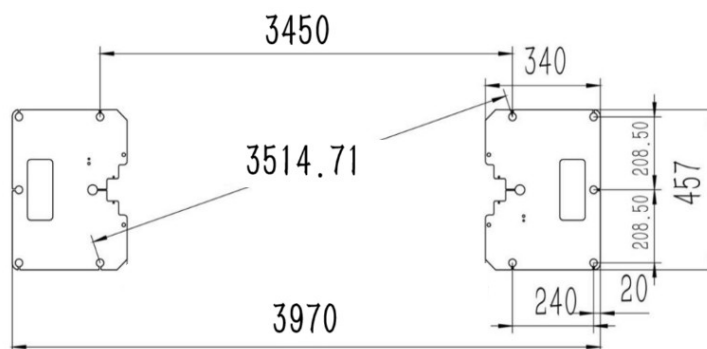

Figure 12b **Frame layout for M120 Lift**

CAUTION

- ***All the dimensions are in millimeters and based on the external border of the base plate.***
- ***Ensure the variance of marking the above layout on the floor is controlled within 6mm. This will ensure elimination of any difficulties in the final assembly, or early wear or miss-alignment of the chain.***
- ***The marking and layout step is very important. Any inaccuracy in marking the layout can cause issues with the final assembly and operation.***

Post Assembly:

Step 1 – For base frame and cross beam two post lift, first install post extension with the **Power Side Post** as shown below fasten the screws marked by the arrows. See Fig.13 for further clarification and final post assembly. Assemble the Offside Post in the same manner as the Power Side Post.

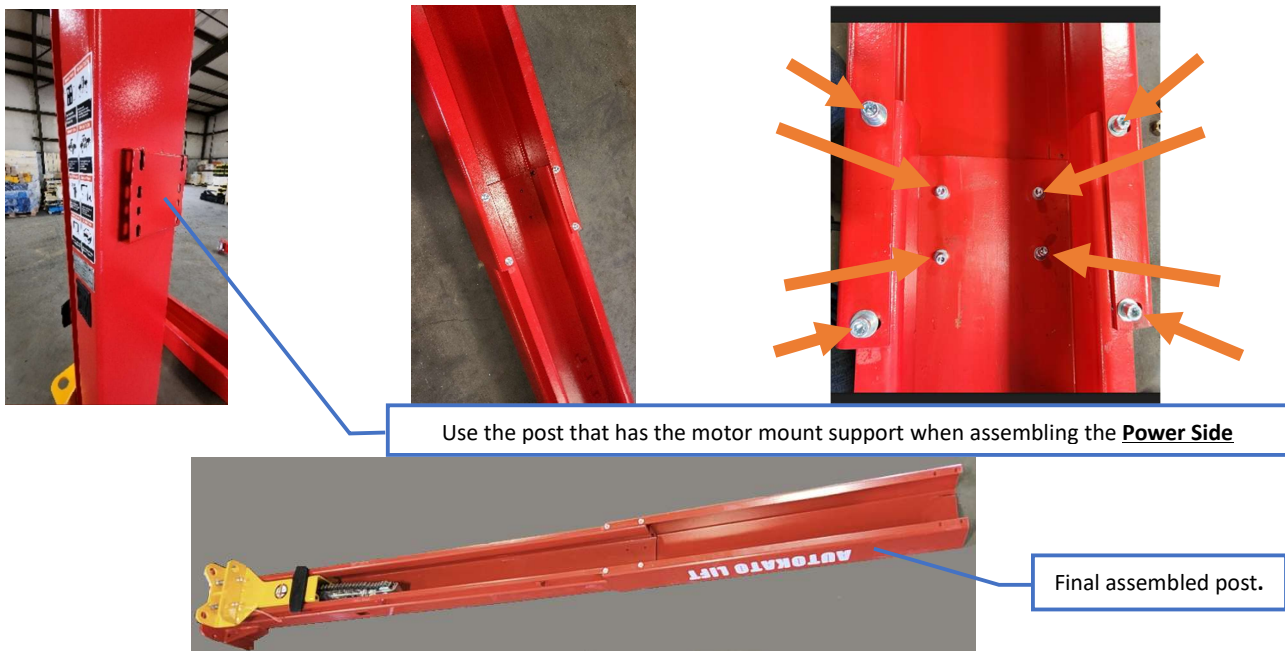
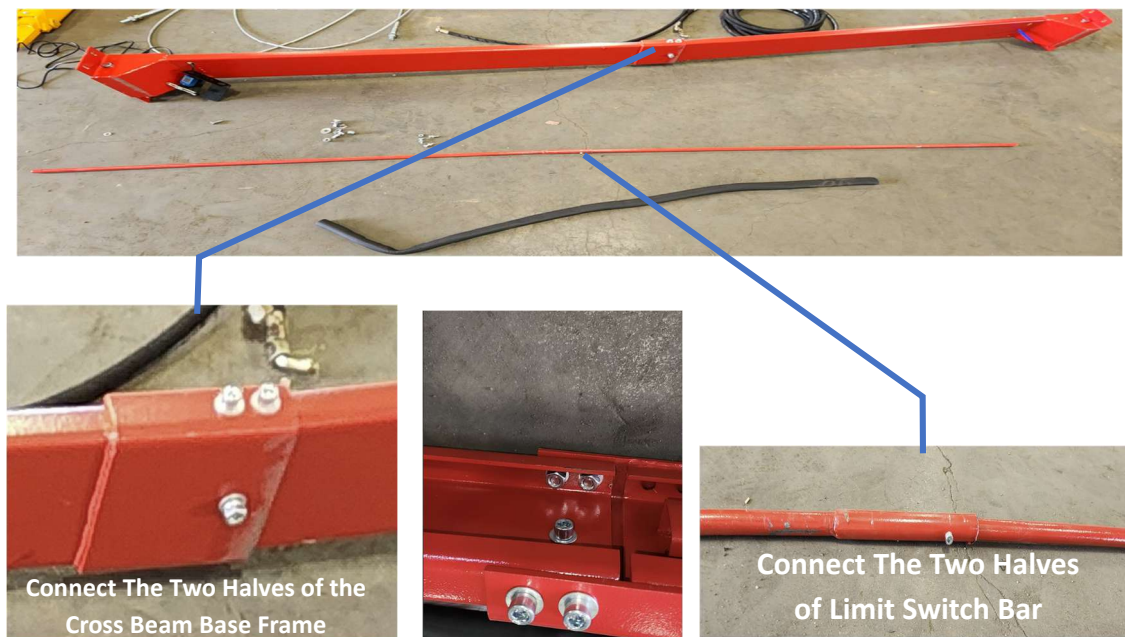
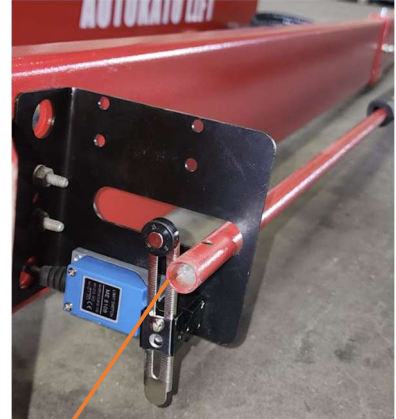
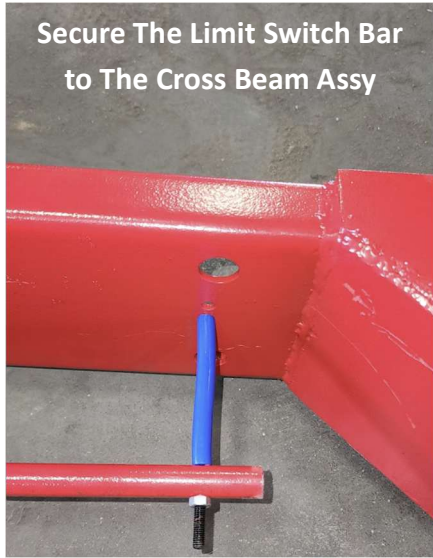

Figure.13 Post and extension assembly

Step 3 - Next, assemble the cross beam/overhead assembly. Join the two halves of the cross-beam base frame as shown below.





Limit Switch Assembly

Attach this side to the Offside Post

Attach this side to the Power Side Post



Post Installation :

Use a forklift to stand upright the post and align the base plate of column with the chalk line layout. Guided by holes on the base plate of the column, use 5 concrete anchor bolts to fix it onto the ground. Drill and install anchor provided in the hardware package.

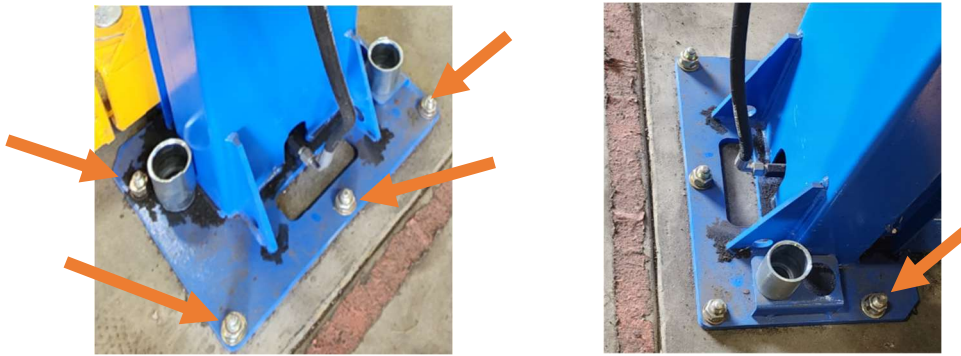

Figure 14

During the drilling process, ensure there is no movement of the column. (Fig.12).

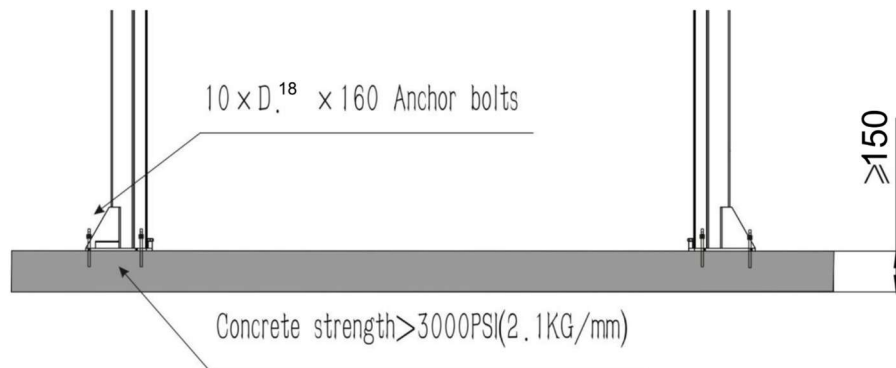

Figure 14

⚠ CAUTION

Note:

- ***Use sharp $\Phi 19\text{mm}$ concrete drill-bit to drill the holes so as not to drill the hole too large, use proper pneumatic tool to remove the dust from the hole. The depth of the hole is the same as that of the anchor Bolt. Insert the anchor Bolt and make the washers lean against the base of the column.***

- ***Only use torque wrench instead of impact tools to fasten anchor bolts.***
- ***Insert proper steel shim under the base seat of column to plumb the column.***
- ***Note: The thickness of shims shouldn't exceed 5mm.***

WARNING

To ensure correct and safe installation, please follow the following safety steps.

- Wear the safety goggles
- Use hard alloy drill-bit.
- Don't use the drill-bit with wearing exceeding the tolerance.
- The drill and concrete surface should be kept perpendicular.
- Let the drill work itself. Don't apply the extra force, and don't ream the hole or allow the drill to wobble.
- The drilling depth of hole is based on the length of anchor Bolt .The distance from the Bolt head to the concrete
- floor should be more than twice of the Bolt diameter.
- Remove the dust from the hole.
- Gently tap the Bolt into the hole till the washer rests against the base plate of column.
- Fasten Bolts

Install and adjust the balancing steel cables

Raise the two carriages to the safety locking position, make sure the two carriages are of the same height from ground. Route the steel cables as shown in Fig. 15. Adjust the tension of cables through the adjustment nuts on each end of steel cable. The steel cables should be tight in equal tension.

⚠ CAUTION

Make sure to install the cable loops around all pulleys before setting up the tension in the cables.

Cable Installation:

Cable Installation Around the Pulleys

To install the cable around tight spaces, spin the pulley such that the notched side of the pulley is facing the plate. This will give you the clearance to feed the cable around the pulley.

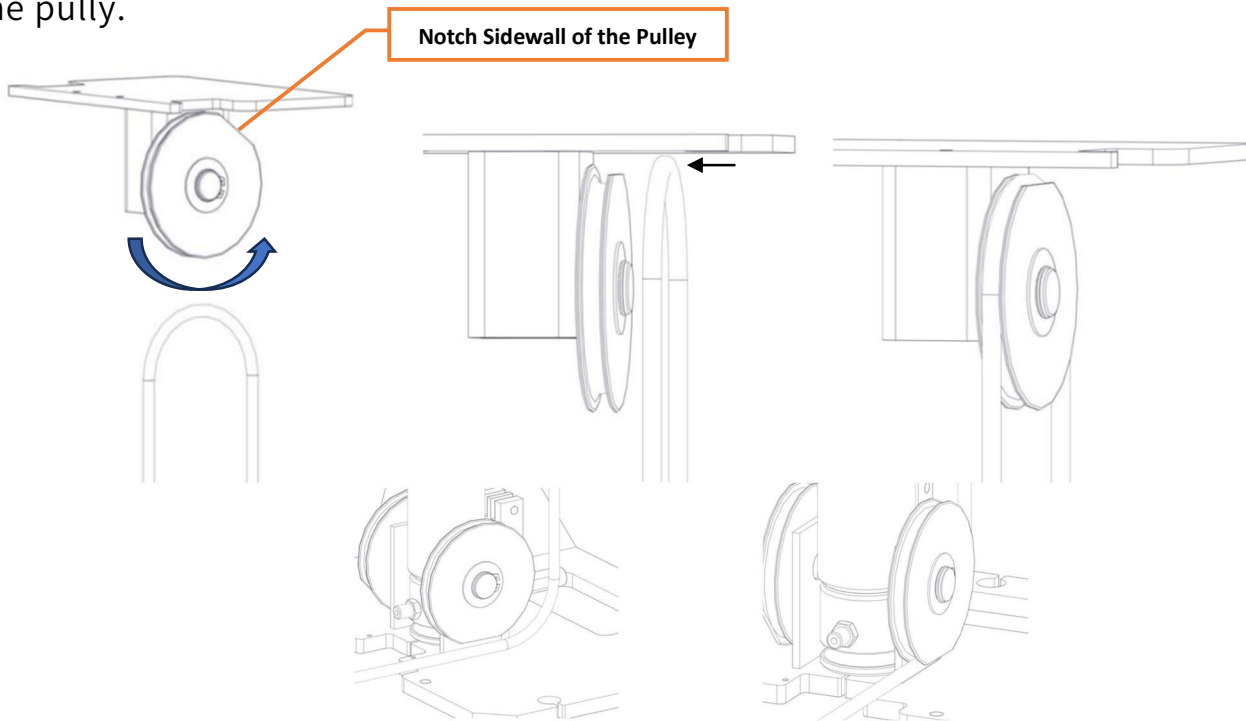

Follow the green arrows to install the **Power Side Cable** and follow the blue arrows to install the **Offside Cable**

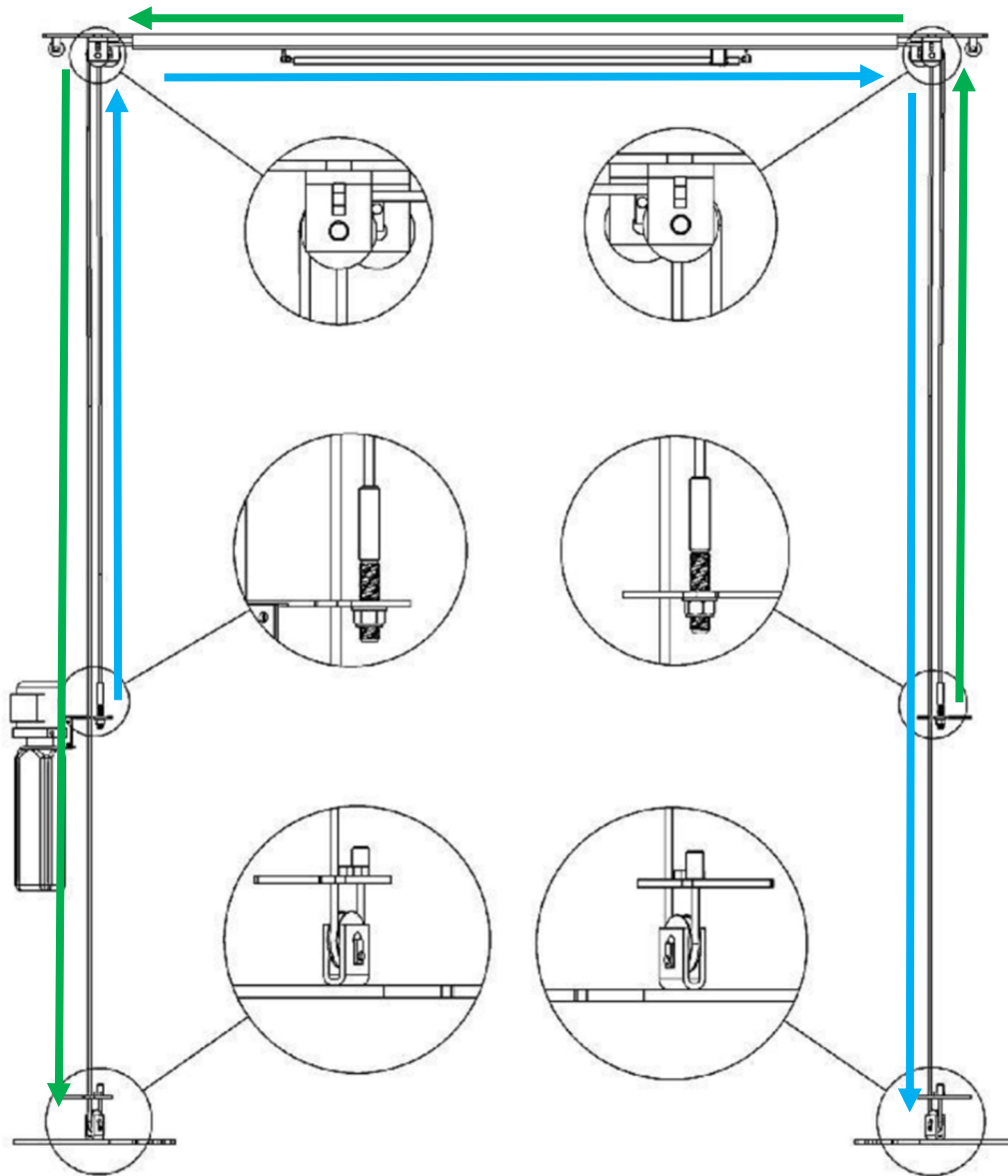

Figure 15

CAUTION

Note:

Make sure to adjusted the tension in each cable such that they are equal to ensure the two carriages move synchronously whenever they are actuated.

Power Unit and Hydraulic Line Installation:

Use two M10 Bolt s and washers to install the power unit (as shown in Fig. 16). Install the hydraulic line as shown in Fig. 18 and tighten all the fittings to prevent oil leakage.



Figure 16

Fill the reservoir with hydraulic oil N32 or N46 (oil capacity of 10L) to the oil reservoir of the power unit up to Max Fill Mark on the oil level dip stick. Fill the reservoir carefully to avoid dust and other pollutants to mix with the hydraulic oil.



CAUTION

Note:

- **Clean the impurities in the hydraulic line and remove the protective plug from the hydraulic cylinder.**
- **When the hydraulic hose installation needs to go through the column, ensure the hydraulic hose won't touch any movable parts inside the column**

Hydraulic Tube Installation:

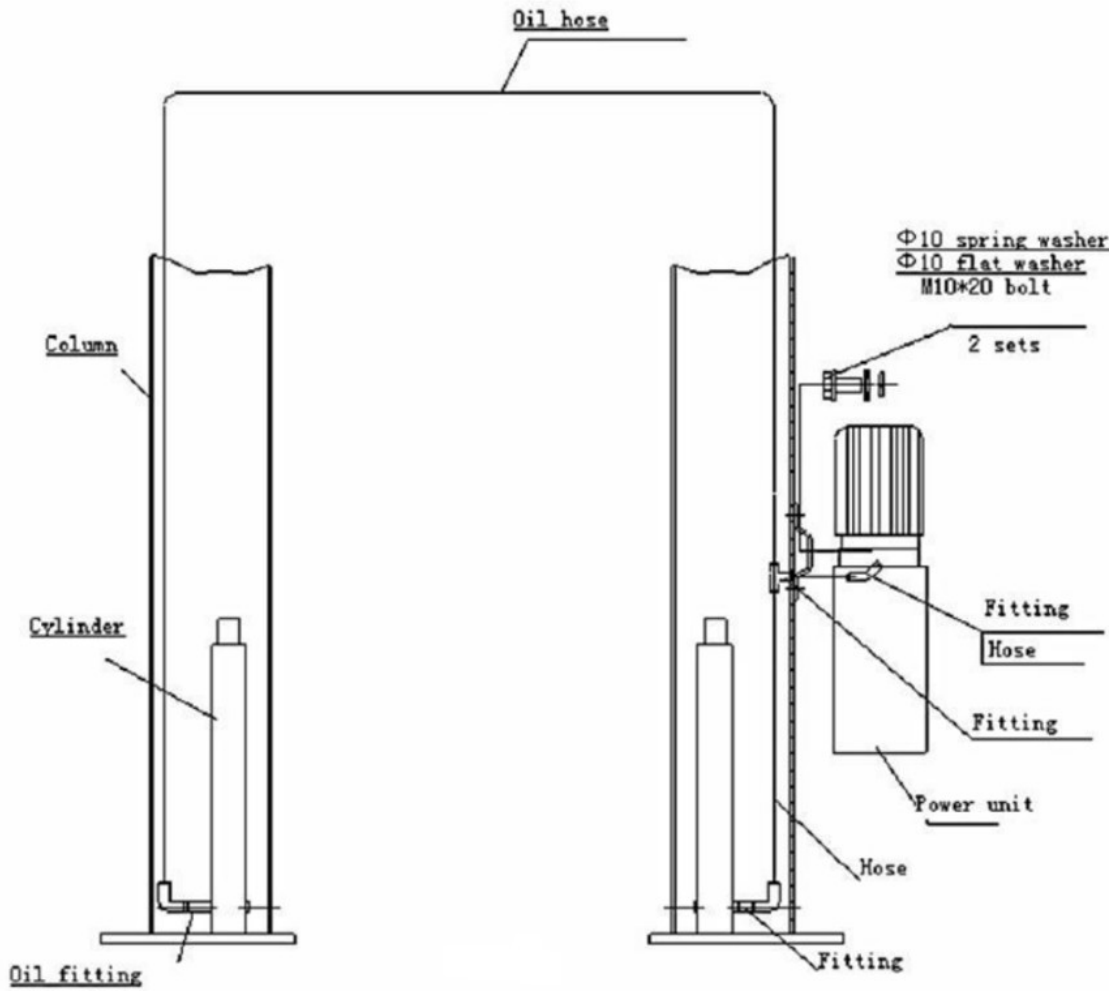
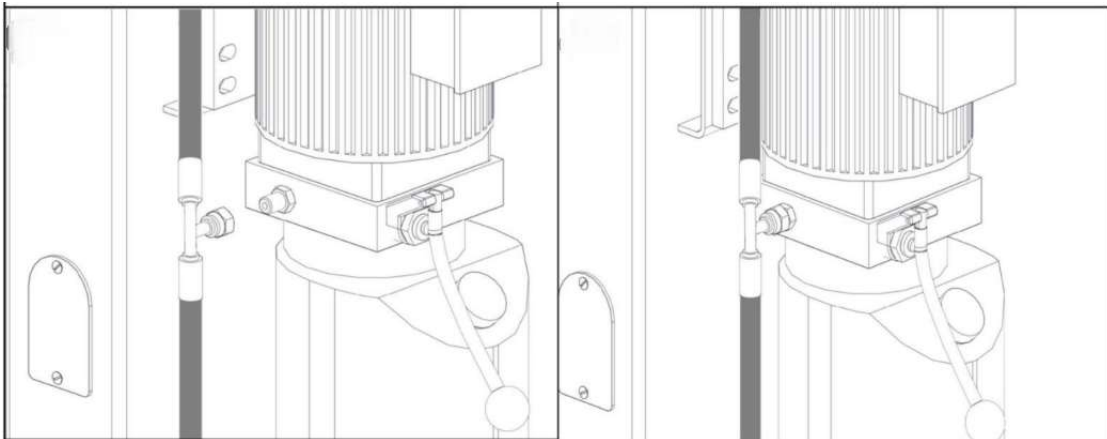

Figure 17



Connect the T-fitting to the Hydraulic Power Unit.



Connect the other short end of the tubing with elbow fitting to the Power side Hydraulic Cylinder.

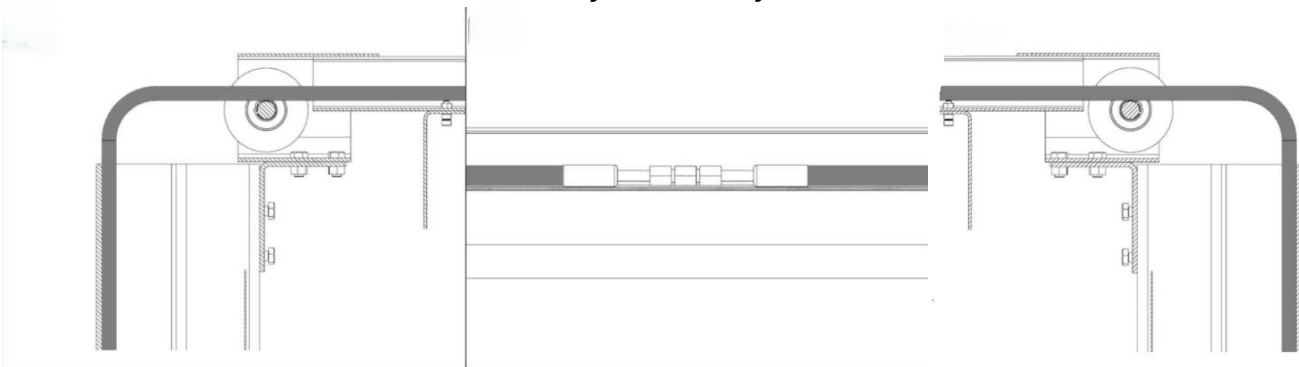

Connect the other long end of the tubing with elbow fitting to the Offside Hydraulic Cylinder after running the tubing up to the overhead assembly and down to the cylinder.

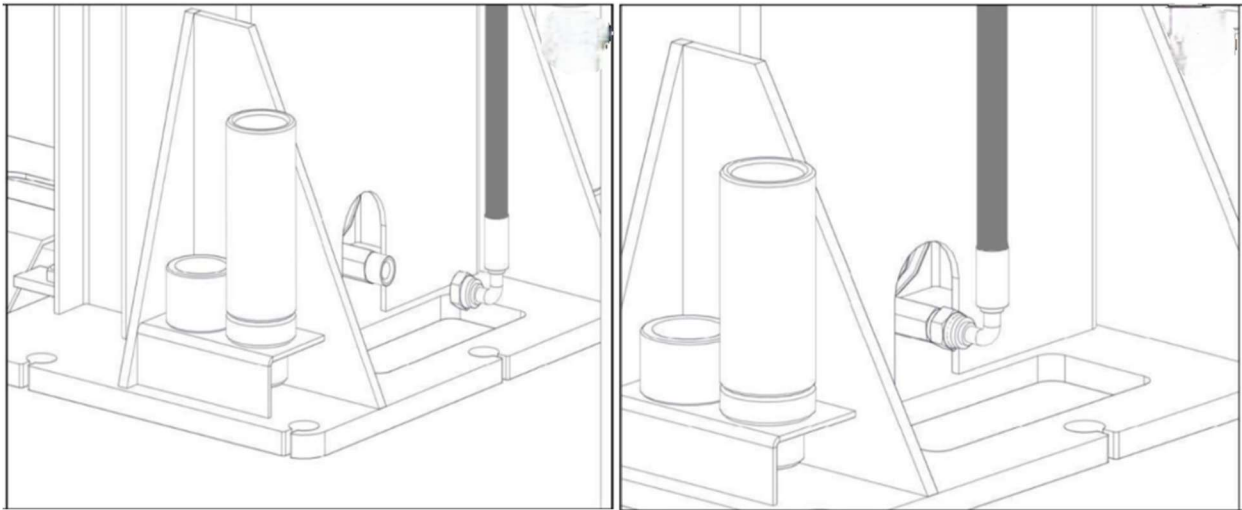

Install the swing arm:

While inserting the pivot pin keep your fingers clear of the pinch point



Pivot Pin

Locking Pin

Place the arm in position and drop the pivot pin to hold the arm in place.



Bevel Gear

Pull the locking pin up and swing it clockwise out of the way as shown. Place the bevel gear with the screw holes aligned and secure it in place with the (3) socket head cap screws provided.



Next pull the locking pin up and swing locking gear anti-clockwise over the bevel gear and drop it down to engage it with the bevel gear to lock the swing arm in position.

Install the tool holder bracket and place the tool holder tray in the bracket as shown below.



10.0.2 Electrical Installation:

The lifts are offered in two electrical configurations:

- 110VAC/60HZ/1PH
- 220VAC/60HZ/1PH

Locate the serial number plate on power side post as shown below or the pump serial number plate to locate the voltage required for the equipment as shown below. Make sure to hire a professional electrician to connect the power to the junction box on the pump.

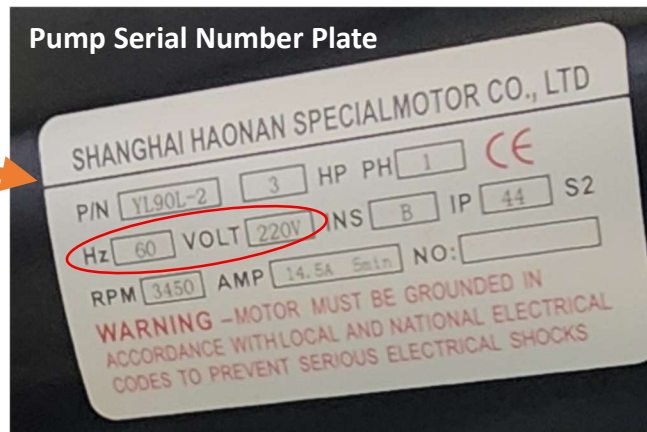

Wire Color Coding

Brown = Hot Leg

Blue = Neutral (may also serve as a 2nd hot leg in 220V setting)

Green/Yellow = Ground

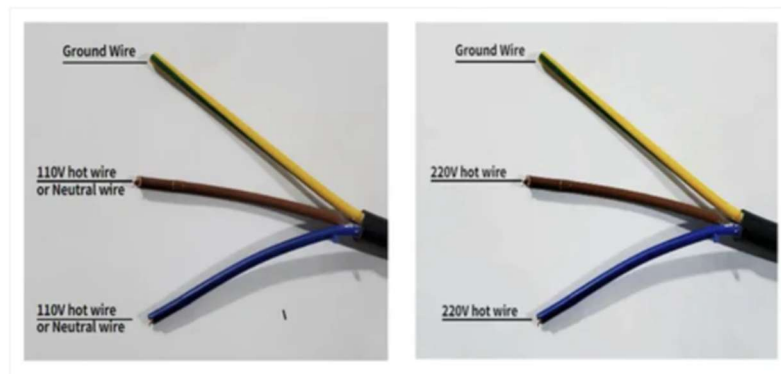

10.0.3 Lift Adjustment:

Preparation before the adjustment:

- Lubricate contact surface of the carriage and corners of column with general-purpose lithium grease. All sliding surface should be coated evenly from top to bottom.

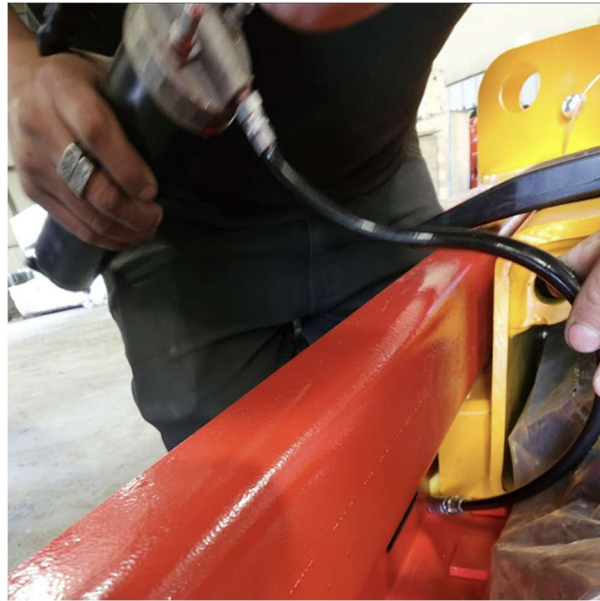

Adjustment procedure:

- Check to see if the power is connected properly.
- Check to make sure that all fasteners and bolts are secured tight.
- Raise the carriages to check the equalizer cable tension by grasping the adjacent cables between the thumb and the forefinger so that you can just pull the cables together. Adjust the nuts on the carriage if necessary.
- Press the start button on the motor to raise the carriage; release the button, to stop the carriage.
- In order to lower the carriage, first pull the steel rope for releasing safety locks on the two carriages. In case the wire does not pull, raise carriage a little and then pull the wire again.

- Press the lowering handle on the power unit to lower the carriage; release the handle, to stop the carriage.
- In case of vehicle repairing, when the vehicle is lifted up to the required height, first press the oil release handle to actuate the mechanical safety lock in order to ensure the safety operation.
- The hydraulic system may contain air due to new installation, to bleed the air, repeat the lifting and lowering for several times.
- The adjustment is completed.

10.0.4 Bleeding a 2-post lift (*Without Bleeder Holes*)

CAUTION

Safety First

- *Make sure the lift is empty (no vehicle on it).*
- *Use jack stands or blocks to support the arms if needed.*
- *Do not put your hands or body under the arms while performing this procedure.*

Steps to Bleed a 2-Post Lift Without Bleeder Screws

- 1) Raise and Lower the Lift Repeatedly
 - Fully raise the lift using the power unit.
 - Let it go as high as it can (safely), then slowly lower it back down.
 - Repeat this process 6–10 times.
 - This motion allows trapped air to move toward the hydraulic reservoir.
- 2) Check Hydraulic Fluid Level
 - After cycling, lower the lift completely.
 - Open the power unit reservoir and check fluid level.
 - Top it off with the correct hydraulic fluid (usually AW32 or ISO 32 unless specified otherwise).
 - Be sure not to overfill — keep it just below the fill hole.
- 3) Inspect for Leaks or Air Ingress
 - Make sure all connections are tight.
 - If air continues to enter the system, check for damaged seals, hoses, or fittings.
- 4) Signs the system is properly bled
 - The lift raises evenly.
 - No jerky or slow movements.
 - No unusual noises (e.g., gurgling).
 - No noticeable drop or sag when stopped.

11.0 SAFETY INSTRUCTIONS

Contact with line power voltages can cause death or serious injury.

- **Do not operate equipment with a damaged power cord.**
- **If an extension cord is necessary, a cord with a current rating equal to or greater than that of the equipment should be used.**
- **Do not expose the equipment to rain or wet environment.**
- **Make sure to connect the unit with proper electrical power.**
- **Use a certified electrician to connect the electrical power.**
- **Do not remove or bypass grounding pin.**
- **Only qualified service personnel should service this equipment.**
- **Disconnect power to the unit before servicing.**

Contact with moving parts could cause injury.

- **Keep hands and other body parts away from moving surfaces.**
- **Do not bypass any safety features.**

Debris, dirt, and fluids can cause serious eye injury.

- **Wear approved safety glasses during mount and demount procedures.**

Tools that break or slip can cause injury.

- **Read and understand the operation instructions before using the equipment.**
- **Frequently inspect, clean, and lubricate (if recommended) where designated.**

12.0 Sales and Tech Support Contact info



Contact Info

Main Phone Number: (888) 636-1918

Sales: Ext. 101

sales@autokato.com

Tech Support: Ext. 102

(please follow voicemail prompts for fastest assistance or fill out our technical support form [here](#))

technical.support@autokato.com

Commercial Accounts: Ext. 103

info@autokato.com

Amazon, eBay and Temu Purchase Inquiries:

Please send us a message directly on the platform where you made your original purchase.