



City of Industry,CA
Brookshire,TX
Bolingbrook,IL
Jersey City,NJ
Pooler, GA
Contact Us
Sales:269-888-3554
Technical:716-299-8852
Email:info@autokato.com

INSTALLATION AND OPERATION MANUAL

12,000LB – 5,500KG CAPACITY
TWO-POST CLEAR-FLOOR VEHICLE LIFT

MODELS: KT- M120



READ FIRST



Do not operate this machine until you read and understand all the dangers, warnings and cautions in this manual.

There is a detailed installation video on our youtube channel:@katool1251



DANGER

Read the entire contents of this manual prior to setup or operation. Failure to follow the instructions and safety precautions in this manual can result in serious injury or death. Make sure all other operators also read this manual. Keep the manual near the product for reference. By proceeding with setup and operation, you agree that you fully understand the contents of this manual.

TWO-POST CLEAR-FLOOR VEHICLE LIFT

READ THIS ENTIRE MANUAL BEFORE INSTALLATION & OPERATION BEGINS.

Product/Item Code	Two post lift / 771.304
Brand	
Model	
Colour	
Voltage	
PO No.	
MADE IN CHINA	



This information is required when calling for parts or warranty issues.

PRODUCT WARRANTY

Our comprehensive product warranty means more than a commitment to you; it's also a commitment to the value of your new KATOOL lift. For full warranty details and to register your new lift contact your nearest KATOOL dealer or visit

www.katoolautoequip.com

We offer a limited one-year (12 months) warranty on all parts and against all product defects, free of charge to our customers, **on all equipment**.

* Including but not limited to: Cylinders, power units, motors, displays, electronics, etc...

Vehicle lifts will include an additional three-year (36 months) warranty on all lift **structural components only**.

Warranty claim for all products must fall within above period in order to qualify for limited warranty.

Warranty is non-transferable, must have original order number, and purchased from our company or a registered vendor. Replacement Parts will be provided at no cost to the customer and will include free shipping.

All warranty claims submitted to KATOOL are subject to approval by the warranty/vice department and may be approved or denied at the full discretion of these departments. Photos and/or videos of original defects may be requested. Customers should not disassemble any piece of equipment before proof of original problem/issue has been determined.

What is NOT covered under this warranty:

- a. Any failure that results from Purchaser's abuse, neglect or failure to operate, maintain or service product in accordance with instructions provided in the owner's manual(s) supplied.
- b. Any damage caused by overloading lift beyond rated capacity.
- c. Items or service normally required to maintain the product, i.e. lubricants, oil, etc.
- d. Items considered general wear parts such as rubber pads, lifting cables, etc. unless wear or failure is a direct result of manufacturer defect due to material and/or workmanship.
- e. Any component damaged in shipment or any failure caused by installing or operating lift under conditions not in accordance with installation and operation guidelines or damaged by contact with tools or surroundings.
- f. Motor or pump failure caused by rain, excessive humidity, corrosive environments or other contaminants.
- g. Rusted components due to improper maintenance or corrosive environments.
- h. Cosmetic defects that do not interfere with product functionality.
- i. Damage due to incorrect voltage or improper wiring.
- j. Any incidental, indirect, or consequential loss, damage or expense that may result from any defect, failure or malfunction of KATOOL Inc. product.
- k. Any equipment outside of the policy will not be covered and buyer will be responsible for purchasing replacement parts at full cost and shipping charges will apply.
- l. Labor is not included in warranty.

IMPORTANT NOTICE

Do not attempt to install this lift if you have never been trained on basic automotive lift installation procedures. Never attempt to lift components without proper lifting tools such as forklift or cranes. Stay clear of any moving parts that can fall and cause injury. These instructions must be followed to ensure proper installation and operation of your lift. Failure to comply with these instructions can result in serious bodily harm and void product warranty. Manufacturer will assume no liability for loss or damage of any kind, expressed or implied resulting from improper installation or use of this product.



**PLEASE READ ENTIRE MANUAL
PRIOR TO INSTALLATION**

DEFINITIONS OF HAZARD LEVELS

Identify the hazard levels used in this manual with the following definitions and signal words:



Watch for this symbol: It Means: Immediate hazards which will result in severe personal injury or death.



Watch for this symbol: It Means: Hazards or unsafe practices which could result in severe personal injury or death.



Watch for this symbol: It Means: Hazards or unsafe practices which may result in minor personal injury, product or property damage.

OWNER'S RESPONSIBILITY

To maintain the lift and user safety, the responsibility of the owner is to read and follow these instructions:

- ◆ Follow all installation and operation instructions.
- ◆ Make sure installation conforms to all applicable Local, State, and Federal Codes, Rules, and Regulations; such as State and Federal OSHA Regulations and Electrical Codes.
- ◆ Carefully check the lift for correct initial function.
- ◆ Read and follow the safety instructions. Keep them readily available for machine operators.
- ◆ Make certain all operators are properly trained, know how to safely and correctly operate the unit, and are properly supervised.
- ◆ Allow unit operation only with all parts in place and operating safely.
- ◆ Carefully inspect the unit on a regular basis and perform all maintenance as required.
- ◆ Service and maintain the unit only with authorized or approved replacement parts.
- ◆ Keep all instructions permanently with the unit and all decals on the unit clean and visible.

BEFORE YOU BEGIN

Receiving:

The shipment should be thoroughly inspected as soon as it is received. The signed bill of lading is acknowledgement by the carrier of receipt in good condition of shipment covered by your invoice. If any of the goods called for on this bill of lading are shorted or damaged, do not accept them until the carrier makes a notation on the freight bill of the shorted or damaged goods. Do this for your own protection.

NOTIFY THE CARRIER AT ONCE if any hidden loss or damage is discovered after receipt and request the carrier to make an inspection. If the carrier will not do so, prepare a signed statement to the effect that you have notified the carrier (on a specific date) and that the carrier has failed to comply with your request.

IT IS DIFFICULT TO COLLECT FOR LOSS OR DAMAGE AFTER YOU HAVE GIVEN THE CARRIER A CLEAR RECEIPT. File your claim with the carrier promptly. Support your claim with copies of the bill of lading, freight bill, invoice, and photographs, if available. Our willingness to assist in helping you process your claim does not make KATOOL responsible for collection of claims or replacement of lost or damaged materials.

TABLE OF CONTENTS

Contents	Page No.
Warranty Information.....	2
Definitions of Hazard Levels.....	3
Owner's Responsibility.....	3
Before You Begin.....	3
Installer/Operator Agreement/ Protective Equipment.....	5
Safety / Warning Instructions.....	6
Selecting Site Notice.....	7
Floor Requirements / Concrete Specifications.....	7
Assembly View / Description of Parts.....	8
Outline /Model Description / Purpose.....	9
Functions & Features / Technical Specifications.....	9
Environmental Requirement.....	10
Lift Structure.....	11
Main structure principles.....	12
Operation Description.....	12
Preparation before operation.....	12
Lifting the Vehicle.....	13
Hydraulic and Electrical system of the Equipment.....	14
Electrical System of the Lift.....	15
Solutions to FAQ.....	16
Repair and Maintenance.....	17
Maintenance of hydraulic system.....	18
Storage and Scrap.....	19
Tools for Installation and Adjustment.....	19
Unpacking&Installation.....	19
Installation Procedure.....	20
Step 1 Selecting installation site.....	20
Step 2 Install the power side column.....	21
Step 3 Raising.....	22
Step 4 Locking&Lowering.....	23
Step 5 Install&adjust the balancing steel cables.....	23-24
Step 6 Install the power unit&hydraulic lines.....	25-26
Step 7 Install the swing arm.....	27
Lift Adjustment.....	28
Declaration of warranty&limitation of liability.....	29
Technical Servicing.....	30-38
Maintenance Log.....	39

**INSTALLER / OPERATOR
PLEASE READ AND FULLY
UNDERSTAND.
BY PROCEEDING YOU AGREE TO
THE FOLLOWING:**

- ◆ I have visually inspected the site where the lift is to be installed and verified the concrete to be in good condition and free of cracks or other defects. I understand that installing a lift on cracked or defective concrete could cause lift failure resulting in personal injury or death.
- ◆ I understand that a level floor is required for proper installation and level lifting.
- ◆ I understand that I am responsible if my floor is of questionable slope and that I will be responsible for all charges related to pouring a new level concrete slab if required and any charges.
- ◆ I assume full responsibility for the concrete floor and condition thereof, now or later, where the above equipment model(s) are to be installed. Failure to follow danger, warning, and caution instructions may lead to serious personal injury or death to operator or bystander or damage to property.
- ◆ I understand that KATOOL lifts are designed to be installed in indoor locations only. Failure to follow installation instructions may lead to serious personal injury or death to operator or bystander or damage to property or lift.



Failure to follow danger, warning, and caution instructions may lead to serious personal injury or death to operator or bystander or damage to property.



THIS SYMBOL POINTS OUT IMPORTANT SAFETY INSTRUCTIONS WHICH IF NOT FOLLOWED COULD ENDANGER THE PERSONAL SAFETY AND/OR PROPERTY OR YOURSELF AND OTHERS AND CAN CAUSE PERSONAL INJURY OR DEATH. READ AND FOLLOW ALL INSTRUCTIONS IN THIS MANUAL BEFORE ATTEMPTING TO OPERATE THIS MACHINE.



Please read entire manual prior to installation. Do not operate this machine until you read and understand all the dangers, warnings and cautions in this manual.

INSTALLER / OPERATOR PROTECTIVE EQUIPMENT

Personal protective equipment helps make installation and operation safer, however, it does not take the place of safe operating practices. Always wear durable work clothing during any installation and/or service activity. Shop aprons or shop coats may also be worn, however loose fitting clothing should be avoided. Tight fitting leather gloves are recommended to protect technician hands when handling parts. Sturdy leather work shoes with steel toes and oil resistant soles should be used by all service personnel to help prevent injury during typical installation and operation activities.

Eye protection is essential during installation and operation activities. Safety glasses with side shields, goggles, or face shields are acceptable. Everyday eyeglasses only have impact resistant lenses, they are not safety glasses. Back belts provide support during lifting activities and are also helpful in providing worker protection. Consideration should also be given to the use of hearing protection if service activity is performed in an enclosed area, or if noise levels are high.

INTRODUCTION

1. Carefully remove the crating and packing materials.
CAUTION! Use care when cutting steel banding material as items may become loose and fall, causing injury.

2. Check the voltage, phase, and proper amperage requirements for the motor shown on the motor plate. Wiring **MUST** be performed by a certified electrician only.

IMPORTANT SAFETY INSTRUCTIONS

Read these safety instructions entirely.

IMPORTANT NOTICE

Do not attempt to install this lift if you have never been trained on basic automotive lift installation procedures.

Never attempt to lift components without proper lifting tools such as forklift or cranes.

Stay clear of any moving parts that can fall and cause injury.

- Read and understand all instructions and all safety warnings before operating lift.
- Care must be taken as burns can occur from touching hot parts.
- Do not operate equipment with a damaged cord or if the equipment has been dropped or damaged until it has been examined by a qualified service person.
- Do not let a cord hang over the edge of the table, bench, or counter or come in contact with hot manifolds or moving fan blades.
- If an extension cord is necessary, a cord with a current rating equal to or more than that of the equipment should be used. Cords rated for less current than the equipment may overheat. Care should be taken to arrange the cord so that it will not be tripped over or pulled.
- Always unplug equipment from electrical outlet when not in use. Never use the cord to pull the plug from the outlet. Grasp plug and pull to disconnect.
- Let equipment cool completely before putting away. Loop cord loosely around equipment when storing.
- To reduce the risk of fire, do not operate equipment near open containers of flammable liquids (gasoline).
- Adequate ventilation should be provided when working on operating internal combustion engines.
- Keep hair, loose clothing, fingers, and all parts of body away from moving parts. Keep feet clear of lift when lowering. Avoid pinch points.
- **DANGER!** To reduce the risk of electric shock, do not use on wet surfaces or expose to rain. The Power Unit used on this lift contains high voltage. Disconnect power at the receptacle or at the circuit breaker switch before performing any electrical repairs. Secure plug so that it cannot be accidentally plugged in during service. or mark circuit breaker switch so that it cannot be accidentally switched on during service.
- KATOOL requires all operators to read and be familiar with ANSI/ALI ALIS *Safety Requirements for Installation and Service of Automotive Lifts*.
- **ALWAYS WEAR SAFETY GLASSES.** Everyday eyeglasses only have impact resistant lenses, they are not safety glasses.
- Consider work environment. Keep work area clean. Cluttered work areas invite injuries. Keep areas well lit.
- Guard against electric shock. This lift must be grounded while in use to protect operator from electric shock. Never connect the green power cord wire to a live terminal. This is for ground only.
- Only trained operators should operate this lift. All non-trained personnel should be kept away from the work area. Never let non-trained personnel come in contact with, or operate lift.
- **DO NOT** override self-closing lift controls.
- Clear area if vehicle is in danger of falling.
- **ALWAYS** make sure the safeties are engaged before attempting to work on or near a vehicle.
- **WARNING! RISK OF EXPLOSION.** This equipment has internal arcing or sparking parts which should not be exposed to flammable vapors. This machine should not be located in a recessed area or below floor level.
- **MAINTAIN WITH CARE.** Keep lift clean for better and safer performance. Follow manual for proper lubrication and maintenance instructions. Keep control handles and/or buttons dry, clean and free from grease and oil.
- Check for damaged parts. Check for alignment of moving parts, breakage of parts or any condition that may affect operation of lift. Do not use lift if any component is broken or damaged.
- **NEVER** remove safety related components from the lift. Do not use lift if safety related components are missing or damaged.
- **STAY ALERT.** Use common sense and watch what you are doing. Remember, **SAFETY FIRST.**



SAVE THESE INSTRUCTIONS

IMPORTANT NOTICE

These instructions must be followed to ensure proper installation and operation of your lift. Failure to comply with these instructions can result in serious bodily harm and void product warranty. Manufacturer will assume no liability for loss or damage of any kind, expressed or implied resulting from improper installation or use of this product.

PLEASE READ ENTIRE MANUAL PRIOR TO INSTALLATION

Selecting Site Notice

Before installing your new lift, check the following.

1. **LIFT LOCATION:** Always use architects plans when available. Check layout dimension against floor plan requirements making sure that adequate space is available.
2. **OVERHEAD OBSTRUCTIONS:** The area where the lift will be located should be free of overhead obstructions such as heaters, building supports, electrical lines etc.
3. **DEFECTIVE FLOOR:** Visually inspect the site where the lift is to be installed and check for cracked or defective concrete.



4. **OPERATING TEMPERATURE.** Operate lift only between temperatures of 41° -104° F.
5. Lift is designed for **INDOOR INSTALLATION ONLY.** Outdoor use is prohibited.

Floor Requirements



This lift must be installed on a solid level concrete floor with no more than 3-degrees of slope. Failure to do so could cause personal injury or death.



A level floor is suggested for proper use and installation and level lifting. If a floor is of questionable slope, consider a survey of the site and/or the possibility of pouring a new level concrete slab.



- ◆ **DO NOT** install or use this lift on any asphalt surface or any surface other than concrete.
- ◆ **DO NOT** install or use this lift on expansion seams or on cracked or defective concrete.
- ◆ **DO NOT** install or use this lift on a second / elevated floor without first consulting building architect.

CONCRETE SPECIFICATIONS

LIFT MODEL	CONCRETE REQUIREMENTS
12,000 Lb Models:	6.5" Min. Thickness 3,000 PSI



All models **MUST** be installed on 3,000 PSI concrete only, conforming to the minimum requirements shown above. New concrete must be adequately cured for 28 days.

When removing the Lift from shipping angles, pay close attention as the Posts can slide and can cause injury. Prior to removing the Bolts, make sure the Posts are held securely by a Forklift, Shop Crane, or some other heavy lifting device.

PARTS INVENTORY

Be sure to take a complete inventory of parts prior to beginning installation.

Description	Qty
Overhead Assembly	1
Lift Arm Assemblies	4
Frame Contact Pads	4
Frame Cradle Pads	4
Offside Post	1
Powerside Post	1
Post Extension Weldments	2
Hydraulic Cylinder	2
Parts Box	1
Hydraulic Power Unit	1

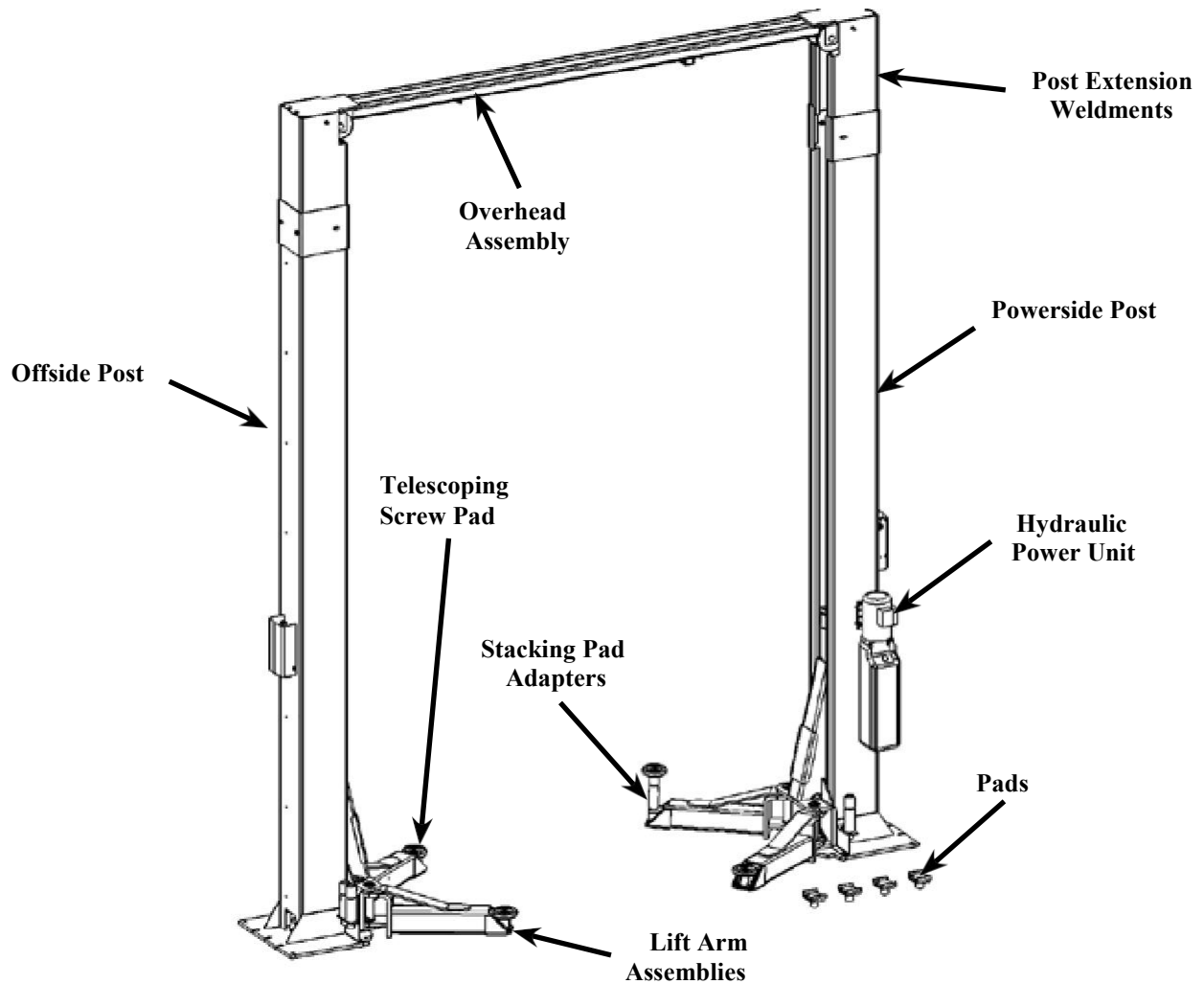

1. Outline

1.1 Model Description

Model	Description
KT-M120 Two-Post Clear-Floor Vehicle Lift	12000lbs, Symmetric 2-post lift with cross beam (Fig.2)

1.2 Purpose

This machine is applicable for the lifting of various small and medium-sized vehicles with total weight 12000lbs in garage and workshop.

1.3 Functions and Features

- The cable and oil pipe are fully concealed, with decent and elegant appearance.
- Designed based on the international standard, meeting the demand of the garage and workshop.
- Top limit switch, effectively protecting the vehicle from overhead collision.
- Dual hydraulic cylinders drive, stable lifting and lowering.
- Manual lowering, safe and simple in operation.
- Adopt two steel cables for equalization, force two carriages to move synchronously, and effectively prevent the vehicle from tilting.
- Lowest height of lifting pad is 110mm, good for repairing low chassis or low profile car.

1.4 Technical Specifications

Noise: Working noise: ≤75dB (A)

Power unit:

Electrical parameters of the machine:

Motor (optional)

Voltage: According to client's requirement

Single phase: 110V/60Hz 2.2kW, 220V/50Hz 2.2 kW, 200V/60Hz 2.2 kW

Three phase 380V/50Hz 2.2 kW

Basic parameters of the equipment:

Model	Rated load	Lifting height	Rising time	Descent time	Net weight	Passing width	Machine width	Machine height
KT-M120	12000lbs	72.83" (1850mm)	≤50s	≥20s ≤40s	820kg	133.46" (3390mm)	157.87" (4010mm)	166.73" (4235mm)

1.5 Environmental Requirement

Working temperature: $-5^{\circ}\text{C}\sim+40^{\circ}\text{C}$

Relative humidity: Temperature $+30^{\circ}\text{C}$, relative humidity 80%

Transport/storage temperature: $-5^{\circ}\text{C}\sim+40^{\circ}\text{C}$

Height above sea level: No more than 2000m

2. Lift Structure

2.1 Lift structures are shown as below:

Model	Description
KT-M120	12000lbs, 2-Post Lift with cross frame (Fig.2)

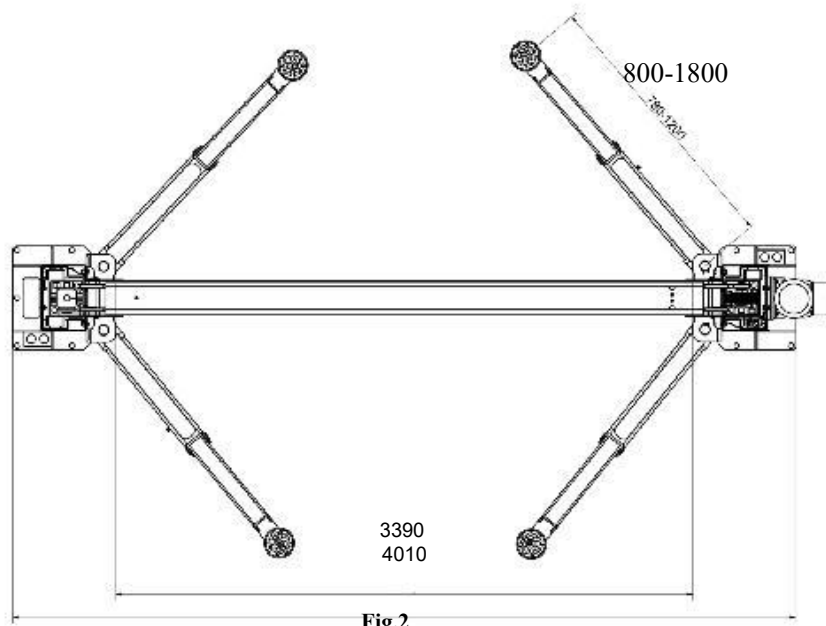
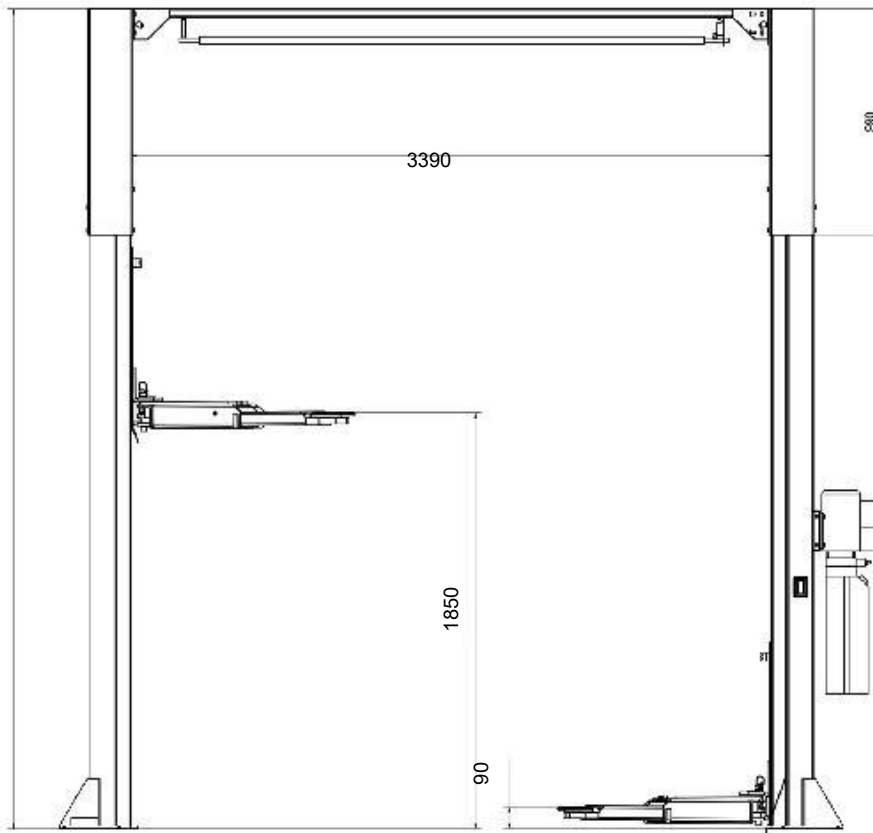

Fig.2

2. Main structure principles:

- **Lifting mechanism:** Each column is installed with a hydraulic cylinder, when hydraulic oil is pressed from power pack into the lower chamber of main cylinder, piston rod moves upwards to drive the upward movement of carriage through leaf chain.
- **Load supporting mechanism:** When vehicle drives into the working area, adjust the angle and telescopic length of arms to make lifting pads at an effective load supporting position that contact with vehicle, then adjust the lower screw's height of lifting pad to make it applicable for vehicles with different chassis.
- **Balance mechanism:** In order to keep machine balanced during lifting and lowering, two carriages are interconnected and forced to move synchronously by two wire ropes. If the right and left carriages and arms are not at the same level, adjust the end nut of wire rope and pull wire ropes tight to make arms leveled.
- **Manual safety locking system:** the safety locking plates are installed on the two carriages and the toothed bar plate is welded on the internal wall of the column. During the lifting of the carriage, the safety locking plate goes up against on the toothed bar plate by the tension of spring. When the carriage stops, the safety locking plate opens and then is engaged in the toothed bar slot to ensure the carriage will not go down; when the lowering operation is required, just raise the carriage upward a little to loosen the safety locking plate from the toothed bar slot, and then manually pull the steel wire rope so as to jack up the safety locking plate by sliding plate, so the safety locking is released so that the carriage can be lowered down. Because the manual safety locking systems are installed on the two carriages, double safety protection can be provided; therefore, to disengage the safety locking, the steel rope on the two carriages shall be respectively pulled. To prevent the vehicle slip, the swing arm is installed with positioning mechanism, making the swing arm capable of automatic locking during operation.
- **Safety lock scope:** Safety lock mechanism is effective when the front end of carriage is between 450mm and 1900mm high above the ground.

3. Operation Description

3.1 Precautions for vehicle repair work

- Different vehicles have different center of gravity positions. First understand the position of center of gravity, and when the vehicle enters into the lift, make its center of gravity close to the plane formed by two columns. Adjust the swing arm, and make the lifting pad support onto the lifting point of the vehicle.
- For vehicle lift with top beam, pay attention to the car roof position observation in order to avoid accident during lifting.
- Carefully read the warning symbol.
- The hydraulic valves have been adjusted before ex-factory, and the user can't make self-adjustment, otherwise it will be responsible for all the consequences generated.
- Based on the production needs, some specifications in the instruction manual are subjected to change without notice.

3.2 Preparation before operation

- Lubricate contact surface of the carriage with general-purpose lithium grease (GB7324-87).
- All sliding surface should be coated evenly from the top to bottom.
- Fill hydraulic oil N32 or N46 to the oil reservoir of the power unit.

3.3 Inspection before operation

- Check to see if the motor power is installed properly.
- Check to see if all the connection bolts are fastened.

 **Note:** Don't operate the lift with damaged cables or damaged and missing part, until it is inspected and repaired by the professionals.

3.4 Lifting the Vehicle

- Keep work area clean, don't operate the lift in cluttered work area.
- Lower the carriage to the lowest position.
- Reduce the swing arm to the minimum length.
- Swing the arm along the route of the vehicle
- Move the vehicle to the location between the two columns
- Swing the arm and put the lifting pad below the recommended lifting point, and adjust the height of lifting pad to touch lifting point of vehicle
- Press the UP button on the electric control box, slowly lift the vehicle to ensure the load balance, and then raise the lift to the required height.
- Release the UP button.
- Press the DOWN button to engage the safety lock of carriage. At this time, the vehicle can be repaired.



Note:

- ***Before operation, the safety locking devices must be Inspected.1) The gear blocks of the arm end must engage the gear block of the restraint shaft.2)No broken strand in the steel cable. 3)No deformation in the arm pad.***
- ***When lifting the vehicle, all the swing arms must be used.***
- ***Before lifting the vehicle, check all the hydraulic hose and fittings for oil leakage. In case of leakage, please don't use the lift. Remove the fitting with leakage and re-seal. Re-install the fitting and check if oil leakage still exists.***
- ***After the vehicle is lifted, when adding or removing any major heavy object, use jack stand to maintain the balance of the vehicle.***

3.5 Lowering the Vehicle

- Clean the work area before lowering the vehicle.
- First press the start button to rise the vehicle a little, then pull two steel ropes on two carriages to disengage the safety lock.
- Press the lowering handle to lower the vehicle.
- Lower the vehicle till the swing arm down to the bottom and the lifting pads leave the vehicle chassis, and then release the lowering handle.
- The swing arms under the vehicle must be fully shrunk.

3.6 Manual emergency lowering

- In case of no electric power or power unit failure, lower the loaded vehicle manually to its initial position as follows:
- Padlock the power switch;
- If the mechanical safeties are engaged, raise the lift a little by using a hydraulic jack or the emergency hand pump (optional), then pull two steel ropes on two carriages to disengage the safety lock.
- Press the lowering handle to lower the vehicle.



Note: When the lift doesn't work, you must switch off the power.

4. Hydraulic and Electrical System of the Equipment

4.1 Hydraulic System of the Lift

Diagram of the hydraulic system of cross beam 2-Postlift

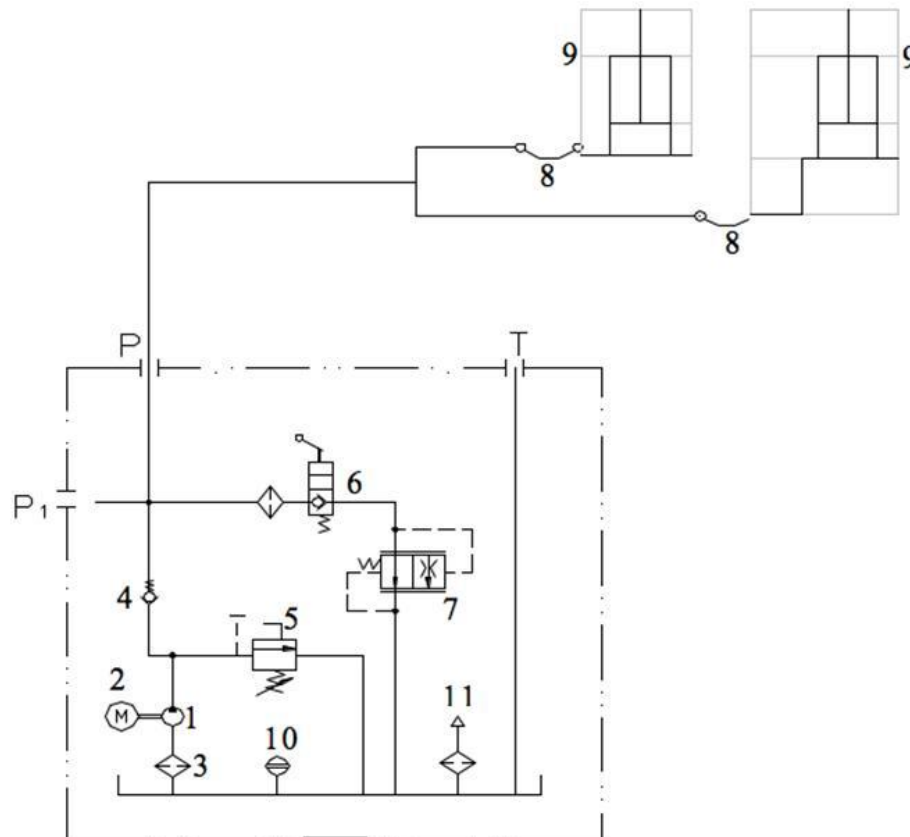

Fig. 3

1- Gear pump, 2-Motor, 3-Oil filter, 4- Check-valve, 5- Safety valve, 6- Lowering handle valve, 7- Servo flow-control valve, 8- Hose, 9- Hydraulic cylinder, 10- Level gauge, 11- Air filter

The working principle of the hydraulic system is as follows:

As shown in Fig.3, when the start button is pressed, the motor 2 is started, driving the oil pump 1, sucking the hydraulic oil from the oil tank into the oil cylinder 9, forcing the piston rod move. At this time, the safety valve 5 is closed. (the Max working pressure is already adjusted before ex-factory. The safety valve can ensure the capacity of the rated load, but when the pressure in the system exceeds the limit, automatically overflow will be happened inside safety valve to protect the hydraulic system).

Release the start button to stop the oil supply and the lifting will stop. For lowering, first start Motor 2 to raise vehicle a little, pull the steel ropes on two carriages to release the safety lock mechanism, then press the lowering handle, the valve 6 is actuated, the hydraulic oil flows back and the lift starts lowering.

4.2 Electrical System of the Lift

Diagram of electrical system for single phase motor

M1-Motor KM-Contactor
 SB –Button
 SQ- Limit switch

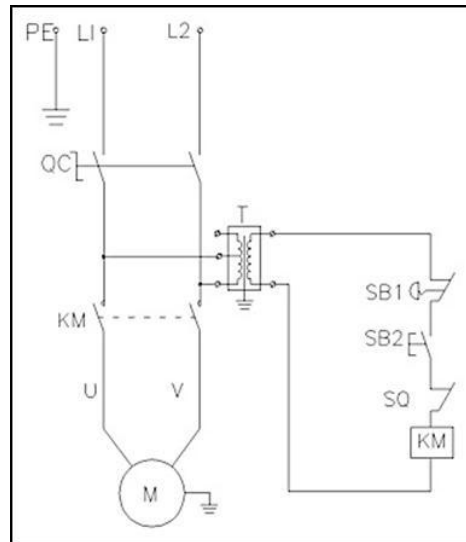

Fig. 4

Diagram of electrical system for three phase motor

M1-Motor KM-Contactor
 SB –Button
 SQ- Limit switch

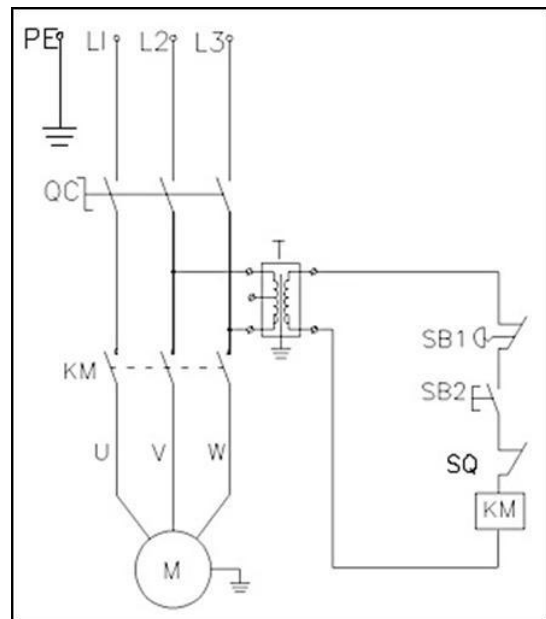

Fig. 5

The electrical working principle is as follows:

Press the start button (SB) ,and the contactor (KM) will be powered; motor (M) is energized to drive the gear pump supplying oil to push the carriage upward; release the start button, and the contactor (KM) is open, then the motor (M) will lose the power, so the carriage will stop rising. As for the cross beam lift, if the vehicle is lifted up to the top and contacts the limit switch on the top beam, the contactor (KM)) will open, then the motor (M) will lose the power, so that the carriage stops lifting. Emergency stop button to emergency power-off function.

5.Solutions to FAQ

Symptom	Reason	Solution
Motor not operation	<ul style="list-style-type: none"> • Check the circuit breaker or thermal relay for tripping • Check the voltage to the motor • Check the electrical wiring • Limit switch is failed • Motor wire is burnt 	<ul style="list-style-type: none"> • Close the switch of circuit breaker or press the blue reset key of thermal relay • Supply correct voltage for motor • Correctly wiring as electrical system diagram • Replace the limit switch • Replace the motor
Motor is running, but the lift can't be raised.	<ul style="list-style-type: none"> • Motor rotation reversed • Lowering valve body open. • Hydraulic pump sucks the air • Suction tube is separate from the hydraulic pump. • Low oil level 	<ul style="list-style-type: none"> • Change the motor rotating direction through changing wire connection. • Repair or replace the lowering valve Body • Fasten all the suction pipe fittings • Replace the suction tube • Add the oil into the oil tank
Motor is running, the lift can be raised without load, but the vehicle can't be raised	<ul style="list-style-type: none"> • Motor is running under low voltage • Impurities inside the lowering valve body • Regulation pressure of safety valve is incorrect. • Lift is overloaded 	<ul style="list-style-type: none"> • Supply correct voltage to the motor • Remove impurities from the lowering valve body. • Adjust the safety valve • Check the weight of the vehicle
The lift is lowering slowly without pressing the lowering handle	<ul style="list-style-type: none"> • Impurities on the lowering valve body. • External oil leakage 	<ul style="list-style-type: none"> • Clean the solenoid valve body • Repair the external leakage
The lifting speed is slow or oil flows out of the oil fill cap	<ul style="list-style-type: none"> • Air and oil are mixed • Air and oil suction are mixed • Oil return pipe is loosened 	<ul style="list-style-type: none"> • Replace the hydraulic oil • Fasten all the suction pipe fittings • Re-install the oil return pipe
The lift can't rise horizontally	<ul style="list-style-type: none"> • Balance cable is not adjusted properly • The lift is installed on the slop floor 	<ul style="list-style-type: none"> • Adjust the balance cable to the proper tension • Shimming the columns to level the lift (no more than 5mm), If exceeding 5mm, pour new concrete floor and make it leveled. Refer to installation description.
Anchor Bolt is not fastened	<ul style="list-style-type: none"> • Hole is drilled too big • Concrete floor thickness or fastening force is insufficient . 	<ul style="list-style-type: none"> • Pour the fast curing concrete into the big hole and re-install the anchor Bolt , or use new drill to drill the hole for re-positioning the lift • Cut open the old concrete and make new concrete slab for the lift. Refer to installation description.



If the problems remain unsolved, call for technical support.

6. Repair and Maintenance

Keep clean

- This unit should be cleaned with dry cloth frequently to keep it clean. Before cleaning, first switch off the power to ensure the safety.
- The working environment of this unit should be clean. In case of dust in the working environment, it will speed up the parts wearing and shorten the service life of the lift.

Every day:

- Before the operation, carefully check the safety mechanism of the lift to ensure the electromagnet suction and release action is proper, and the safety plate is in good condition. When finding any abnormal situation, make adjustment, repair or replacement immediately.
- Check to see if the steel cable connection is proper, and if the tension is at the optimum status.
- Check to see if the connection between hydraulic cylinder and carriage is proper, if the connecting nut between the steel chain and carriage is loose or falling.

Every day:

- Retighten the anchor bolts.
- Lubricate chains/cables.
- Check all the chain connectors, Bolt s and pins to ensure correct installation
- Check all the hydraulic lines for wearing
- Check to see if the carriage and the inner side of the column are properly lubricated. Use high-quality heavy lubrication grease (lithium based lubrication grease GB7324-87).



Note: All the anchor Bolt s should be tightened completely. If any screw doesn't function for some reason, the lift can not be used until the bolt is replaced

Every six months:

- Check all the movable parts for possible wearing, interference or damage.
- Check the lubrication of all the pulleys. If the pulley has dragging during the lifting and lowering, add appropriate lubricant to the wheel axle.
- When necessary, check and adjust the balancing tension to ensure the horizontal lifting and lowering.
- Check the verticality of the column.

 **Note:** *The inner corner of each column should be lubricated with lubricant, to minimize the roller friction and ensure the smooth and even lifting.*

Maintenance of hydraulic system:

- Clean and oil change In the six months after initial use of this unit, clean the hydraulic oil tank and replace the oil, later clean the hydraulic system once a year, and replace the oil. See Fig. 7
- Replace the seal After this unit is put into operation for certain period, if finding the oil leakage, carefully check it; if the leakage is due to the wearing of sealing materials, immediately replace the worn one based on the original spec. See Fig. 7

Diagram of hydraulic line of cross beam 2-post lift

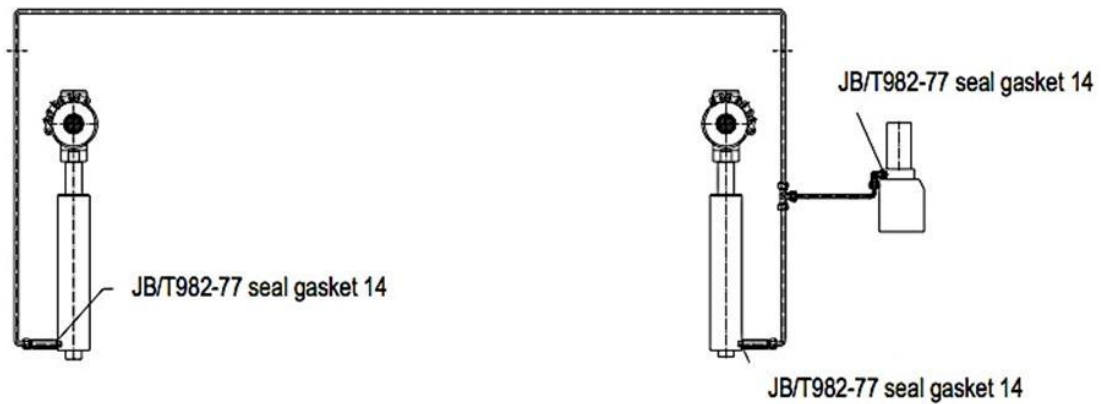
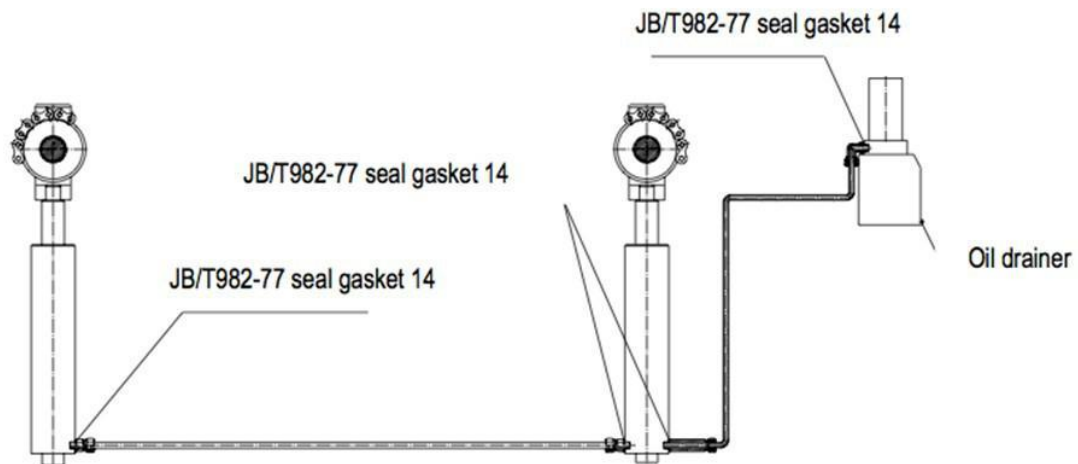

Diagram of hydraulic line of base frame 2-post lift



7. Storage and Scrap

7.1 Storage

- When the equipment requires long-time storage:
- Disconnect the power supply
- Lubricate all the parts requiring lubrication: mobile contact surface of the carriage, etc.
- Empty all the oil/liquid storage units
- Put the plastic cover over the equipment for dust protection.

7.2 Scrap

When the equipment service life is expired and can no longer be used, disconnect the power supply, and properly dispose of as per relevant local regulations.

8. Tools for Installation and Adjustment

To ensure proper installation and adjustment, please prepare the following tools:

Tool	Model
Leveling instrument	Carpentry type
Chalk line	Min 177.17" (4.5m)
Hammer	1.5kg
Medium crescent wrench	1.57" (40mm)
Open-end wrench set	0.43"-0.91" (11mm-23mm)
Ratchet socket set	
Flat Screw driver	5.91" (150mm)
Rotary hammer drill	0.75" (19mm)
Concrete drill-bit	∅ 0.75" (19mm)

9. Unpacking

- Open the packing box; remove the packing materials and inspect the lift for any sign of shipment damage. Check by packing list to see if the main parts and accessories are complete.
- Keep the packing materials away from the children to avoid danger; if the packing materials cause the pollution, they shall be treated properly.

10. Installation

10.1 Important notice

- The wrong installation will cause the lift damage or personal injury. The manufacturer will not undertake any responsibilities for any damage caused due to incorrect installation and usage of this equipment, whether directly or indirectly.
- The correct installation location shall be "horizontal" floor to ensure the horizontal lifting. The slightly slope floor can be corrected by proper shimming. Any big slope will affect the height of the lifting pad when at the bottom or the horizontal lifting. If the floor is of questionable slope, consider a visual inspection, or pour a new horizontal concrete slab if possible. In short, under the optimum horizontal lifting status, the level of the lifting relies on the level of the floor where it is installed. Don't expect to compensate for the serious slope.

- Don't install the lift on any asphalt surface or any surface other than concrete. The lift must be installed on concrete floor conforming to the minimum requirement showed in this manual. Don't install the lift on the concrete with seams or crack and defect. Please check together with the architect.
- Without the written approval of the architect, don't install the lift on a second floor with basement.
- Overhead obstruction: The lift installation area can't have any overhead obstruction, such as heater, building support, electrical pipe, etc.
- Concrete drilling test: The installation personnel can test the concrete thickness at each site by drilling test. If several lifts are installed at one place, it is preferred to make drilling test in each site.
- Power supply: Get ready the power supply before the installation. All the electric wiring and connecting should be performed by a certified electrician.

10.2 Installation Procedure

10.2.1 Selecting installation site

Selecting installation site based on the following conditions:

- Lift can only be installed on concrete slab, which must have a minimum thickness of 150mm and should be aged 7days at least.
- The concrete slab shall have reinforcement by steel bar.
- The concrete slab must be leveled.
- If the thickness of the whole ground concrete is greater than 150mm, the lift can be installed directly
- Check the possible obstruction, e.g. low ceiling, top pipeline, working area, passage, exit, etc.
- The front and back of the lift should be reserved with sufficient space to accommodate all the vehicles (Fig. 8). (evaluating from the center line ,each edge should be about 4m)

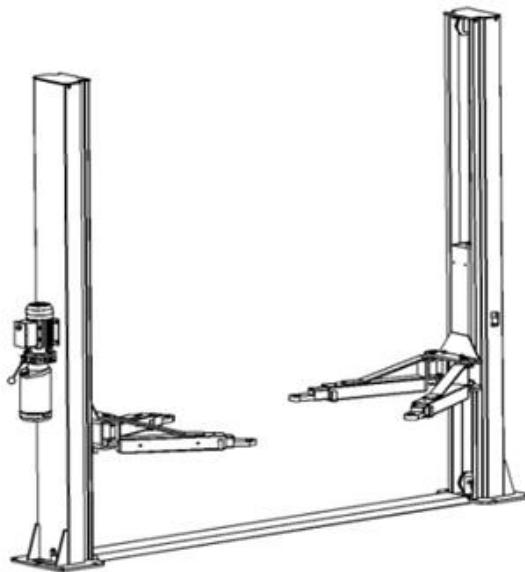

Fig.8

10.2.2 Base frame layout



Fig. 9



- *All the dimensions are based on the external border of the base plate.*
- *Ensure the overall error is controlled within 6mm. In this way, the difficulties in the final assembly, or early wear or non-alignment of the chain can be eliminated. The marking and layout is very important. If it is inaccurate, there will be problems during the final assembly and operation.*

10.2.3 Install the power side column

For base frame and cross beam two post lift ,first install extension column with column, then use lifting equipment to place power side column upper right to the location. Align the base plate of column with the chalk line layout. Guided by holes on the base plate of the column, use 5 concrete anchor bolts to fix it onto the ground. Drill and install anchor Bolt s at one time, during the drilling process, ensure no movement of the column.(Fig.10).

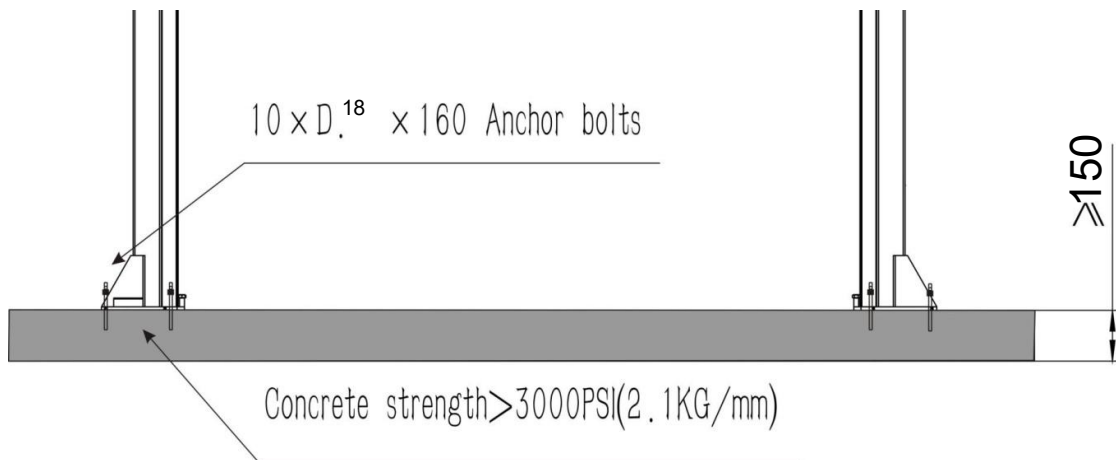

Fig.10



Note:

- **Use sharp $\Phi 19\text{mm}$ concrete drill-bit to drill the holes so as not to drill the hole too large., Use proper pneumatic tool to remove the dust from the hole. The depth of the hole is the same as that of the anchor Bolt . Insert the anchor Bolt and make the washers lean against the base of the column.**
- **Only use torque wrench instead of impact tools to fasten anchor bolts.**
- **Insert proper steel shim under the base seat of column to plumb the column.**



Note: The thickness of shims shouldn't exceed 5mm.

To get the correct and safety installation, please follow the following installation steps.

- Wear the safety goggles
- Use hard alloy drill-bit.
- Don't use the drill-bit with wearing exceeding the tolerance.
- The drill and concrete surface should be kept perpendicular.
- Let the drill work itself. Don't apply the extra force, and don't ream the hole or allow the drill to wobble.
- The drilling depth of hole is based on the length of anchor Bolt .The distance from the Bolt head to the concrete floor should be more than twice of the Bolt diameter.
- Remove the dust from the hole.
- Gently tap the Bolt into the hole till the washer rests against the base plate of column.
- Fasten Bolts

10.2.4 Raising



During raising and lowering cycles: Closely watch the vehicle and the lift, do not allow anyone to stay in lift area and make sure the vehicle doors are closed.

Once the disk adapters contact the lift points, check arm restraints for engagement. After raising the vehicle briefly, stop and check adapters for secure contact.

- Press button on power unit.
- Lift stops once button is released or upward travel limit is reached.

When vehicle is in raised position:

- Slowly position vehicle midway between adapters. Apply the parking brake.
- Swing and telescope arms as required to position adapters under vehicle manufacturer's recommended lift points.
- Turn the disk adapters that they evenly contact all four lift points. Once the disk adapters contact the lift points, check arm restraints for engagement. If necessary, slightly move the arms until the gear segments mesh. Never unlatch the arm restraints when the lift is under load.
- Leave vehicle and remain clear of lift. Always lift the vehicle using all four adapters.

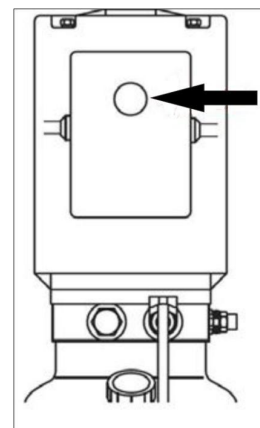

! *Once the disk adapters contact the lift points, check arm restraints for engagement. After raising the vehicle briefly, stop and check adapters for secure contact.*

- Press button on power unit. Lift stops once button is released or upward travel limit is reached. When vehicle is in aised position: Observe all accident prevention regulations.
- Do not allow unauthorized persons to stay under the raised vehicle.
- Avoid rocking of vehicle.
- Keep lift free of tools, parts, etc.
- Keep lift free of tools, parts, etc.
- Fasten the vehicle to the support arms using lashing straps when removing or installing heavy components.

10.2.5 Locking & Lowering

Locking

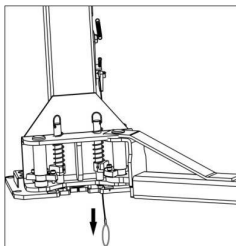

The latch mechanism will 'trip over' when the lift raises and drop into each latch stop. But, to lock the lift you

Must press the lowering lever to relieve the hydraulic pressure and let the latch set tight in a lock position. .

! *Always lock the lift before going under the vehicle. Never allow anyone to go under the lift when raising or lowering. Read the safety procedures in the manual.*

Lowering

! *During raising and lowering cycles: Closely watch the vehicle and the lift, do not allow anyone to stay in lift area and make sure the vehicle doors are closed.*

- Raise the lift until the latches clear the safety racks in both sides.
- Press the lever at the power unit to lower the lift.

Warning: *Always make sure safety latches on both sides clear the rack at same time when pulling down the release handle by adjusting the cable.*

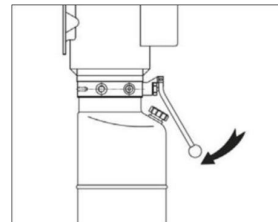

10.2.6 Install and adjust the balancing steel cables

Raise the two carriages to the safety locking position, make sure the two carriages are of the same height from ground. For L1100 models, route the steel cables as Fig. 12a shows, for L1000 models, route the steel cables as 12b shows. Adjust the tension of cables through the adjustment nuts on each end of steel cable. The steel cables should be tight in equal tension. Each steel cable should be ensured in the pulley when adjusting tightly, otherwise the steel cable will be damaged.

⚠ Note: Before operating the lift, re-check the balancing steel cables and ensure they are not crossing or wrongly installed. Ensure the steel cables still in the pulley.

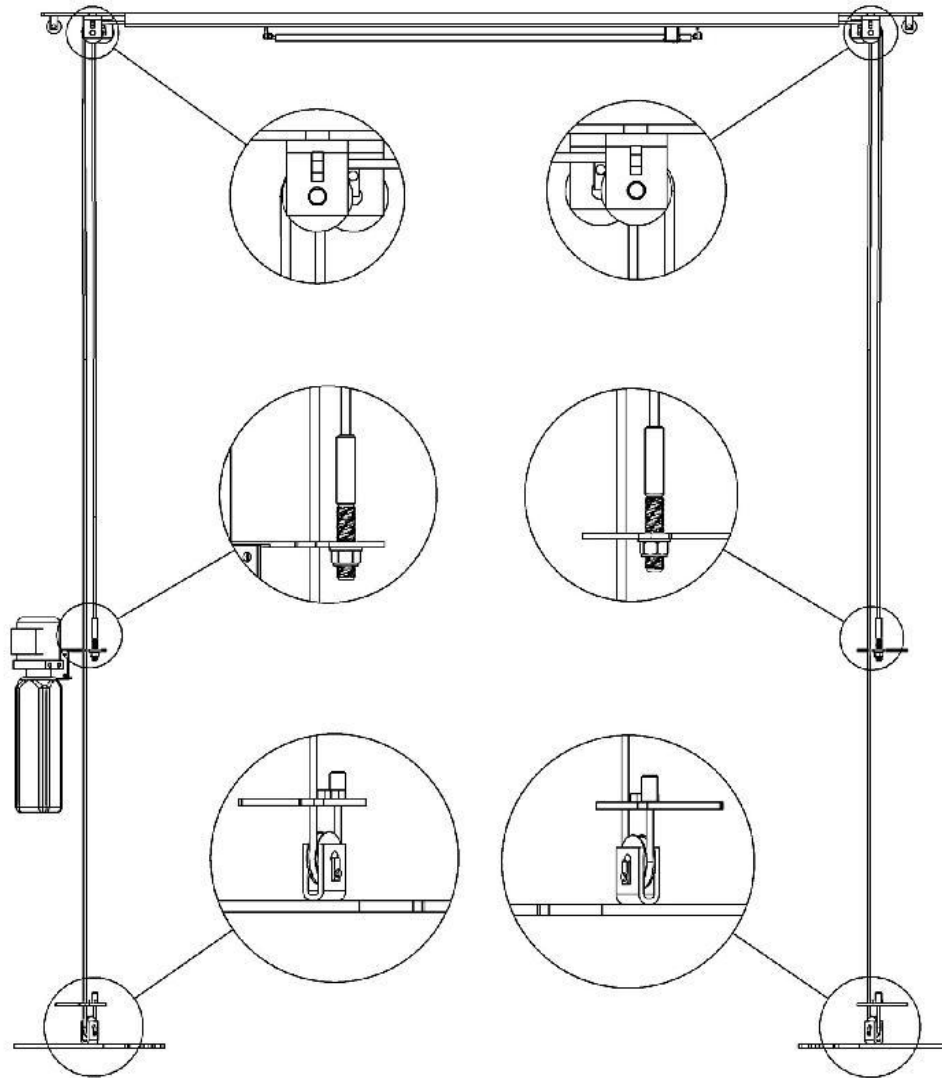

Fig.12a

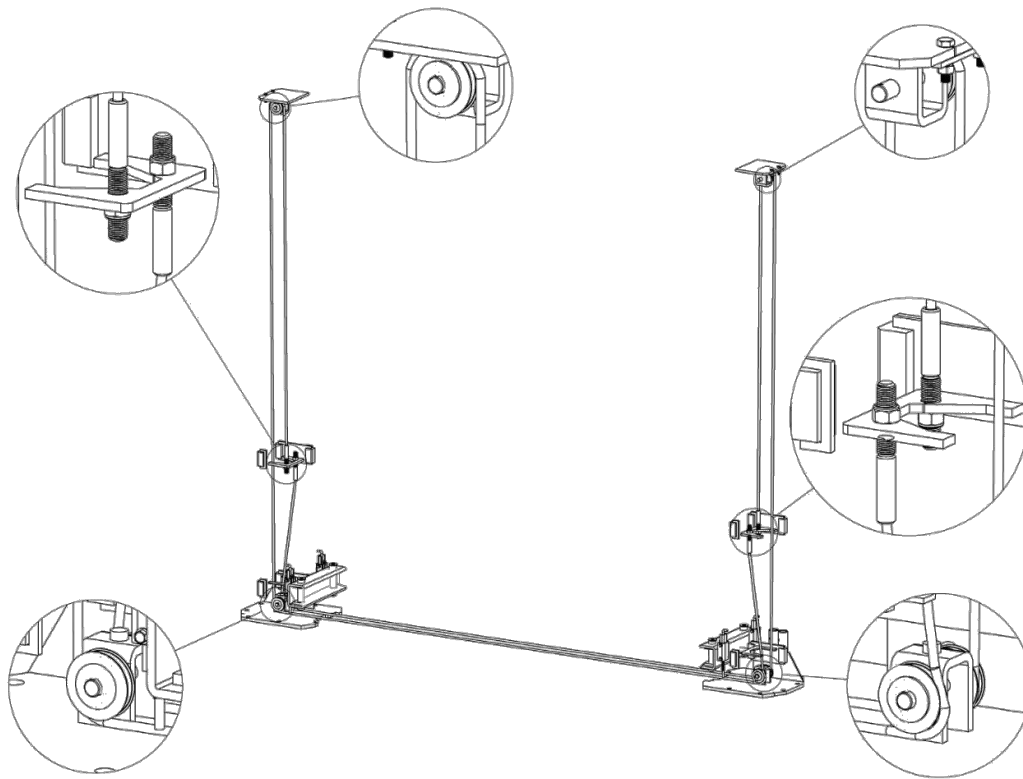

Fig.12b

⚠ Note: *The two steel cables shall be adjusted to certain uniform tension to ensure the two carriages are moving synchronously.*

10.2.7 Install the power unit and hydraulic lines

- Use two M10 Bolt s and washers to fix the power unit (as shown in Fig. 13a、 13b). for L1100 models, install the hydraulic line as shown in Fig. 13a , for L1000 models, , install the hydraulic line as shown in Fig. 13b and tighten all the fittings top revert oil leakage.
- Fill the reservoir with hydraulic oil (oil capacity of 10L). Operate carefully to avoid dust and other pollutants mixed with the hydraulic oil.

⚠ Note:

- *Clean the impurities in the hydraulic line and remove the protective plug from the hydraulic cylinder.*
- *When the hydraulic hose installation needs to go through the column, ensure the hydraulic hose won't touch any movable parts inside the column*

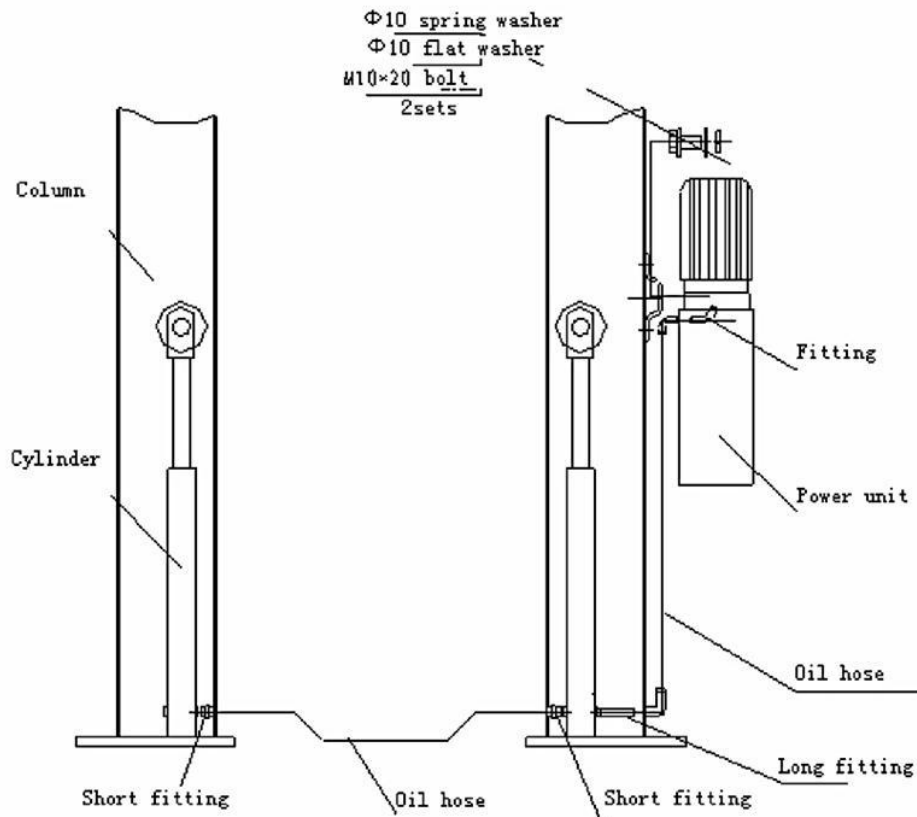
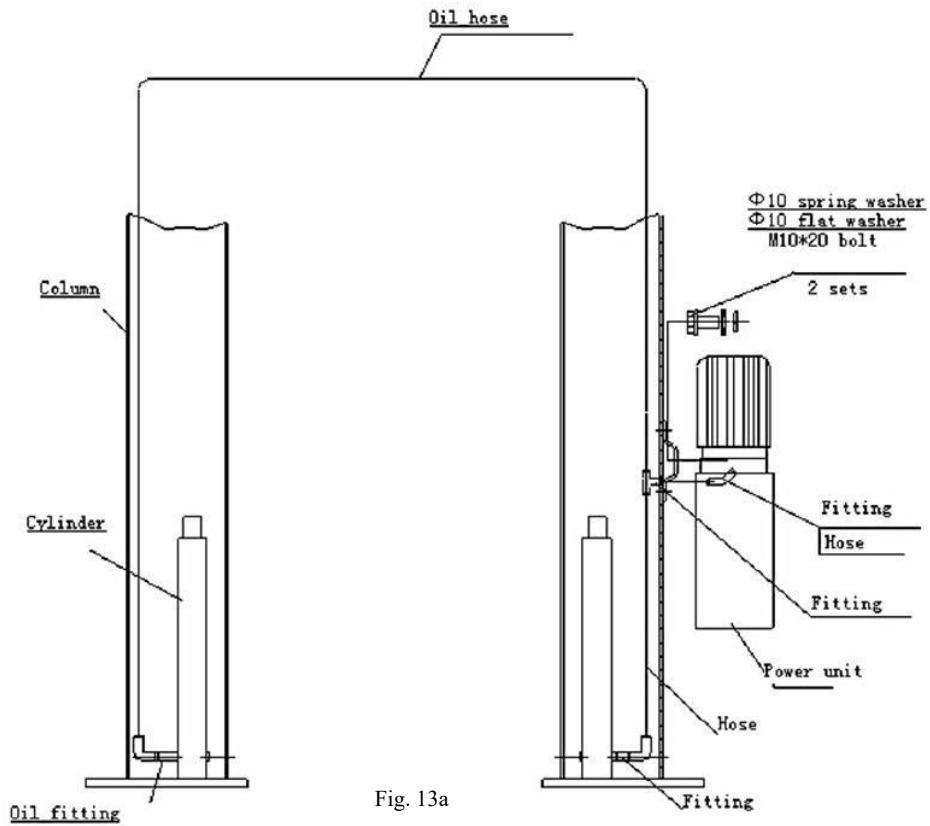

10.2.8 Install the swing arm

Install the swing arm as shown In Fig.14



Before use ,check if the positioning gear mechanism at the end of arm fits, adjust the Screw s of fixed semi-gear for its fitness. During the installation, lubricate the moving parts of swing arm and carriage if accessory, so that the swing arm can move freely.

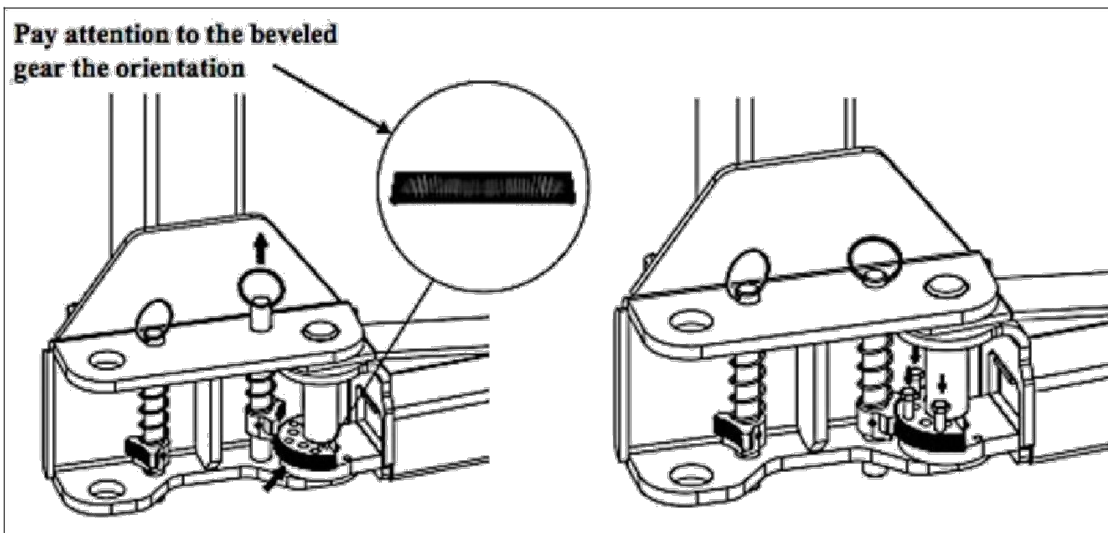
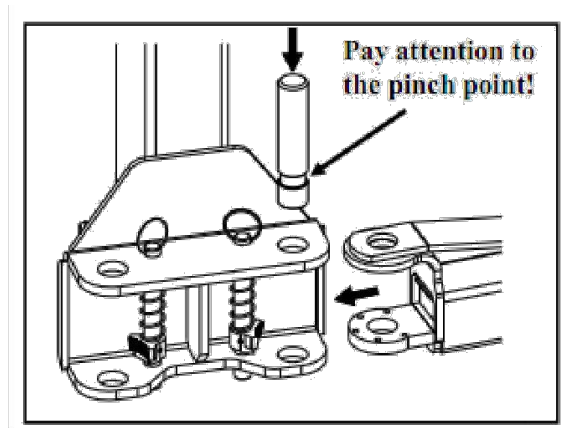

Fig.14

11. Lift Adjustment

11.1 Preparation before the adjustment

- Lubricate contact surface of the carriage and corners of column with general-purpose lithium grease. All sliding surface should be coated evenly from top to bottom.
- Fill hydraulic oil N32 or N46 to the oil reservoir of the power unit.

11.2 Adjustment procedure

- Check to see if the power supply is installed properly.
- Check for the tightness of all the connecting bolts.
- Raise the carriages to check the equalizer cable tension by grasping the adjacent cables between the thumb and the forefinger so that you can just pull the cables together. Adjust the nuts on the carriage if necessary.
- Press the starting button on the motor, and the carriage rises; stop pressing the button, then the carriage will stop.
- In order to lower the carriage, first pull the steel rope for releasing safety locks on the two carriages one time for each. In case of failure to pull the wire, re-pull after raising carriage a little. Press the lowering handle on the power unit and the carriage will be lowered; stop pressing the handle, then the carriage will stop. In case of vehicle repairing, when the vehicle is lifted up to the required height, first press the oil release handle to actuate the mechanical safety lock in order to ensure the safety operation.
- The hydraulic system may contain air due to new installation, to bleed the air, repeat the lifting and lowering for several times.
- The adjustment is completed.

DECLARATION OF WARRANTY AND LIMITATION OF LIABILITY

The manufacturer has paid proper attention to the preparation of this manual. However, nothing contained herein modifies or alters, in any way, the terms and conditions of manufacturer agreement by which this lift was acquired, nor increase, in any way, manufacturer's liability to the customer.

TO THE READER

Every effort has been made to ensure that the information contained in this manual is correct, complete and up-to date. The manufacturer is not liable for any mistakes made when drawing up this manual and reserves the right to make any changes due the development of the product, at any time.

WARRANTY CERTIFICATE

The warranty is valid for a period of 12 months starting from the date of the purchase invoice. The warranty will come immediately to an end when unauthorized modifications to the machine or parts of it are carried out. The presence of defects in workmanship must be verified by the Manufacturer's personnel in charge.

TECHNICAL SERVICING

For all servicing and maintenance operations not specified or shown in these instructions, contact your Dealer where the machine has been bought or the Manufacturer's Commercial Department.

The "ME-LM1100" below
the picture indicate the
correct installation steps.

INSTALLATION MANUAL

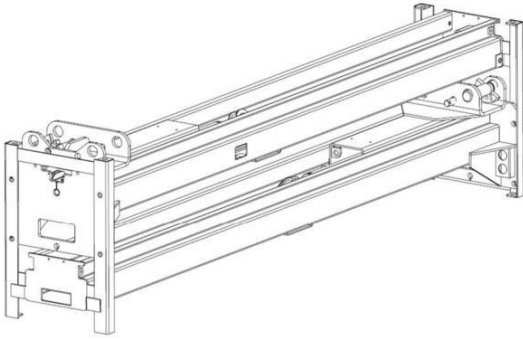
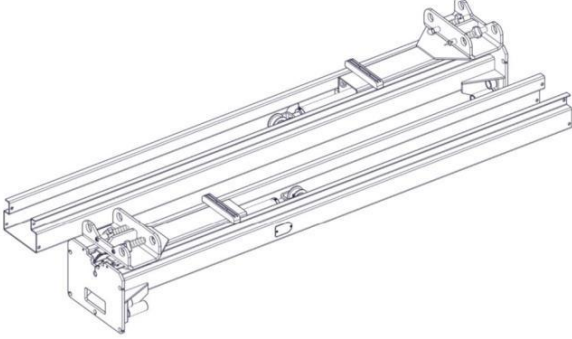
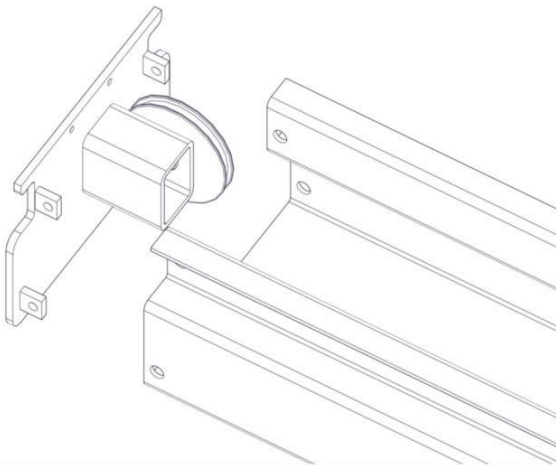
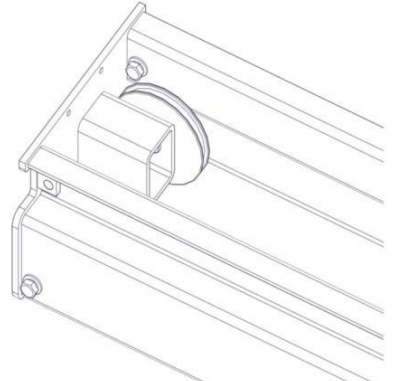
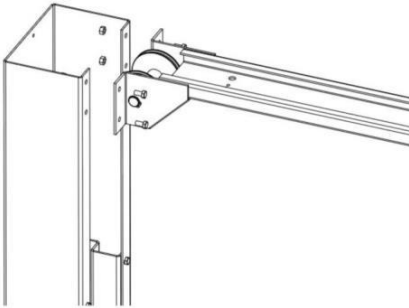
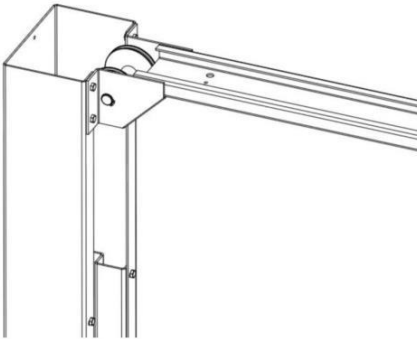
<p>1 Unpack</p>  <p>A perspective view of the KT-M120 assembly, showing the main beam and various mounting brackets and rollers.</p>	<p>2 Take out parts</p>  <p>A perspective view of the KT-M120 assembly, showing the main beam and various mounting brackets and rollers, similar to diagram 1 but with different components highlighted.</p>
<p>KT-M120</p>	<p>KT-M120</p>
<p>3</p>  <p>A close-up view showing a roller being inserted into a bracket on the main beam.</p>	<p>4</p>  <p>A close-up view showing a roller being inserted into a bracket on the main beam, similar to diagram 3 but from a different angle.</p>
<p>KT-M120</p>	<p>KT-M120</p>
<p>5 Install beam</p>  <p>A close-up view showing the main beam being inserted into a vertical support structure.</p>	<p>6 Install beam</p>  <p>A close-up view showing the main beam being inserted into a vertical support structure, similar to diagram 5 but from a different angle.</p>
<p>KT-M120</p>	<p>KT-M120</p>

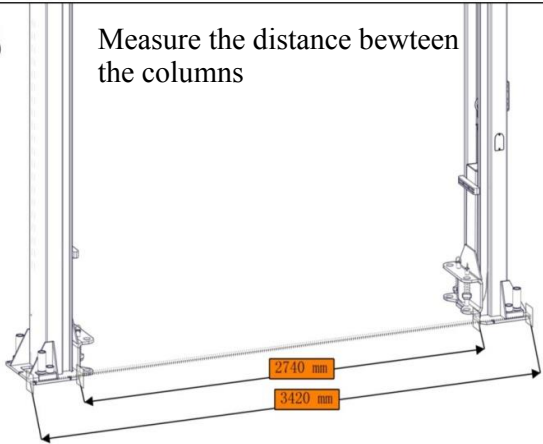
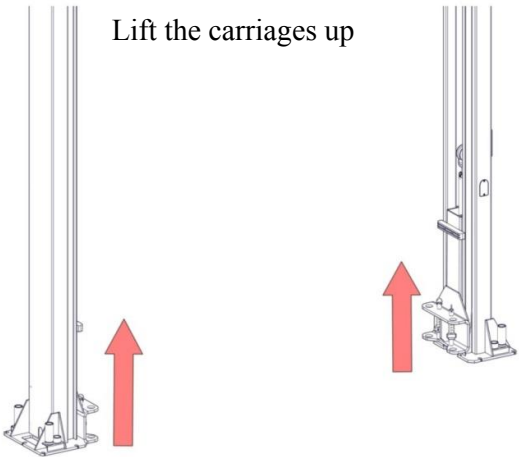
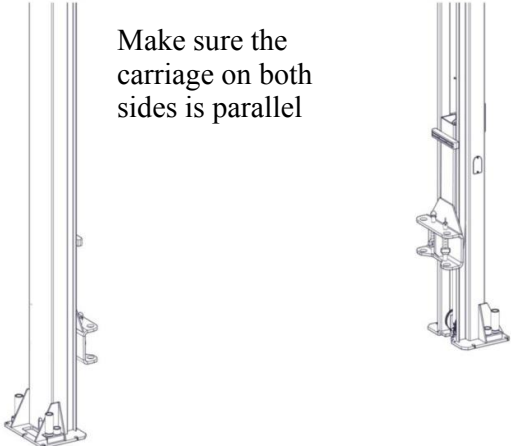
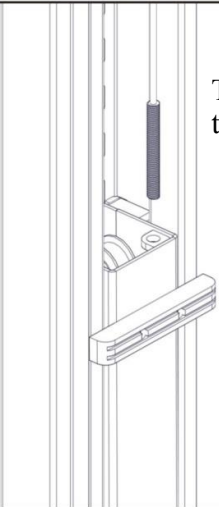
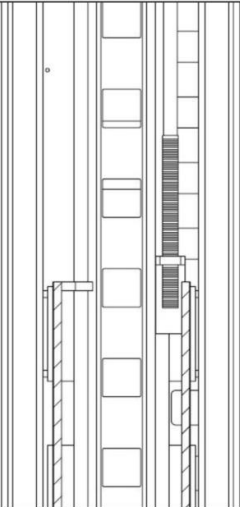
<p>7 Stand the column up</p> 	<p>8 Measure the distance between the columns</p> 
<p>KT-M120</p>	<p>KT-M120</p>
<p>9 Lift the carriages up</p> 	<p>10 Make sure the carriage on both sides is parallel</p> 
<p>KT-M120</p>	<p>KT-M120</p>
<p>11 Thread the wire rope through here</p> 	<p>12 Leave about two inches in length</p> 
<p>KT-M120</p>	<p>KT-M120</p>

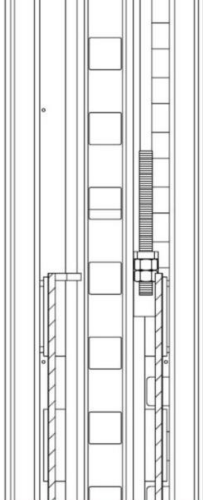
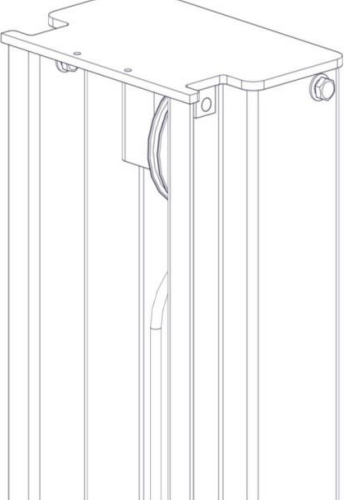
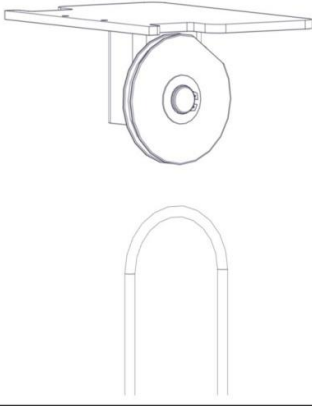
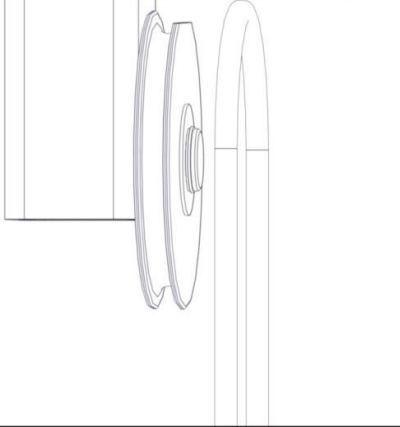
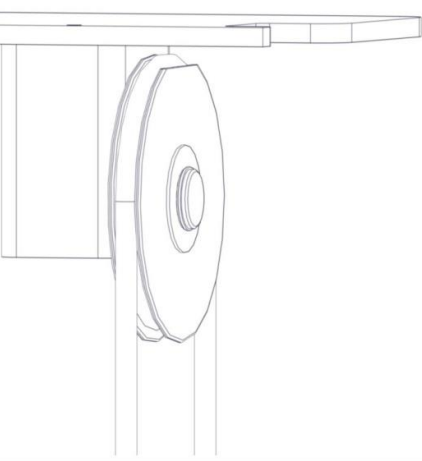
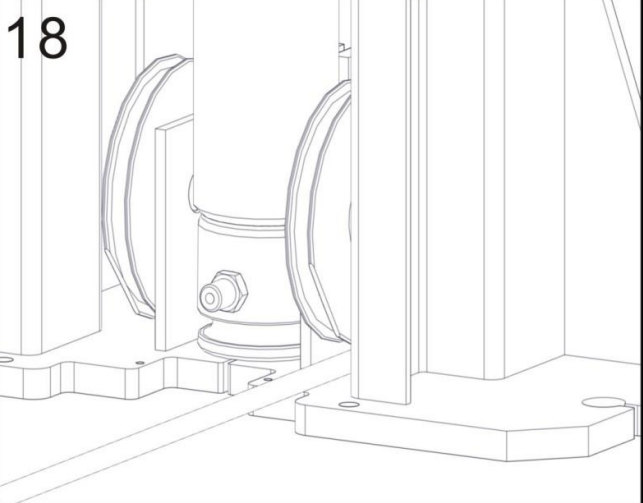
<p>13</p>  <p>Tighten the nut to secure</p>	<p>14</p> 
<p>KT-M120</p>	
<p>15</p> 	<p>16</p> 
<p>17</p> 	<p>18</p> 

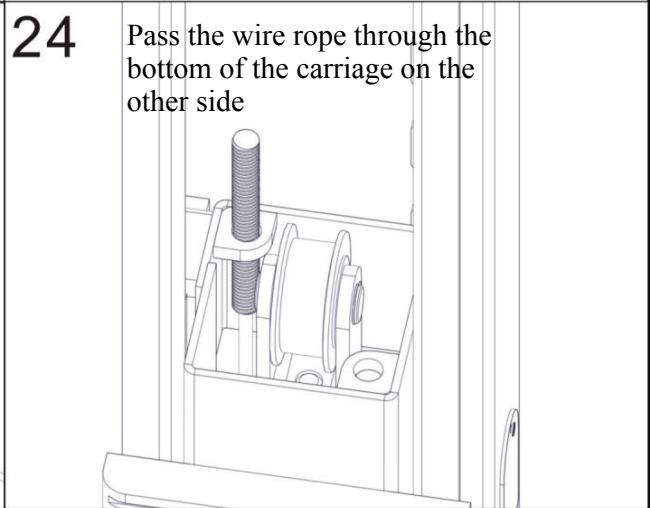
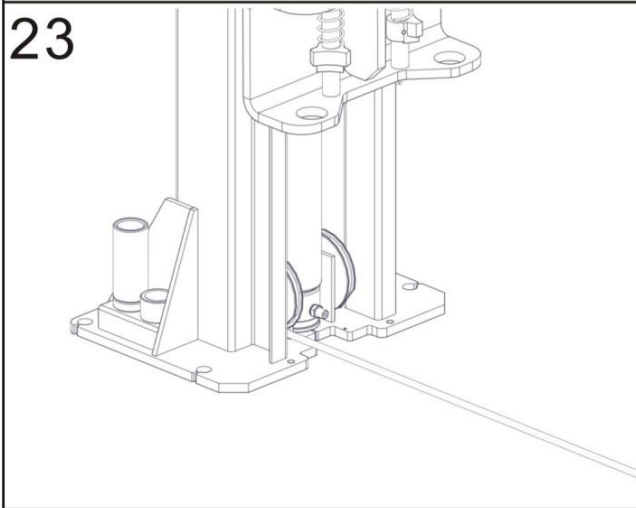
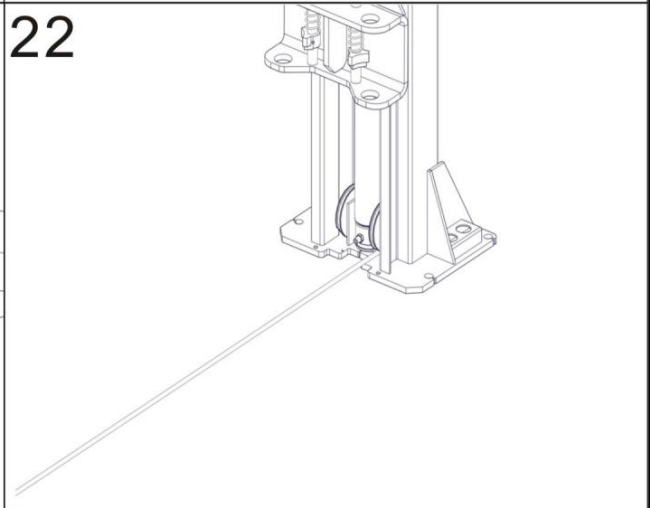
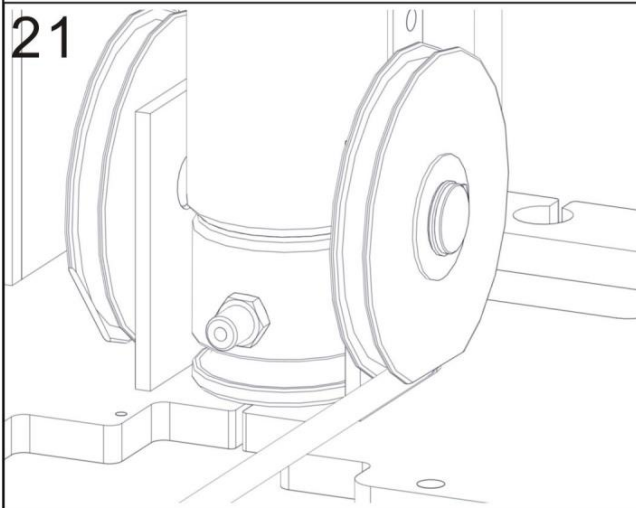
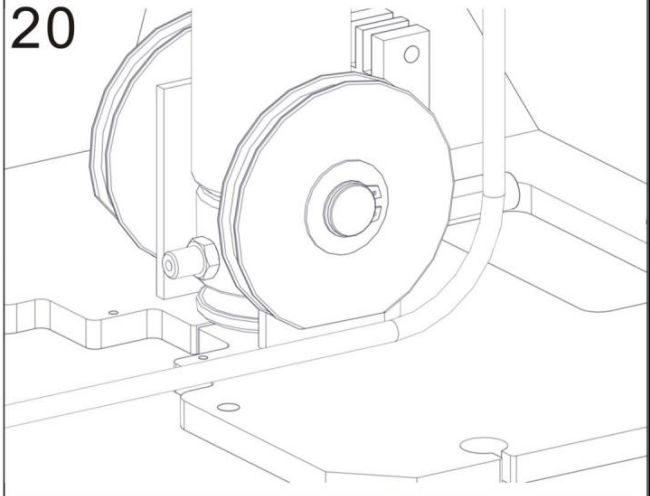
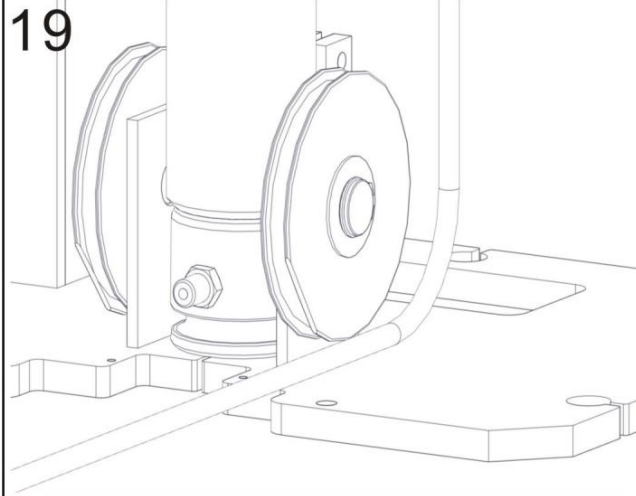

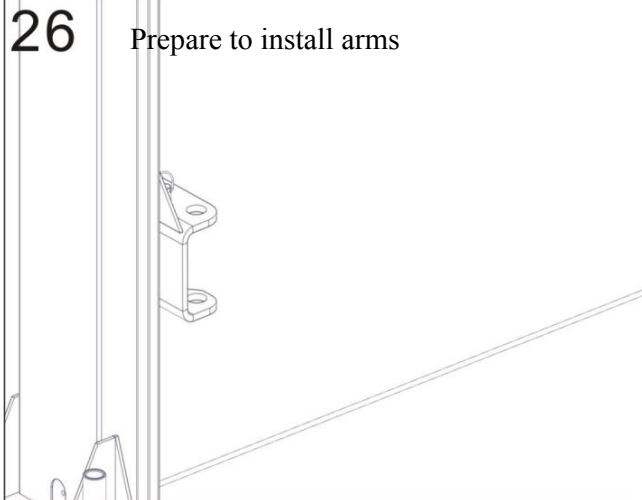
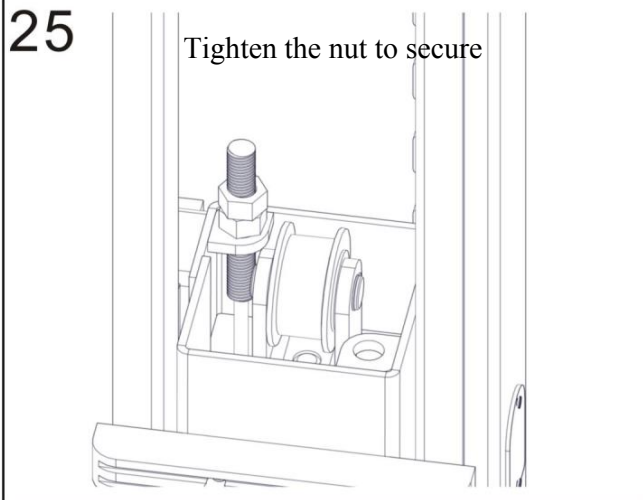

KT-M120

KT-M120

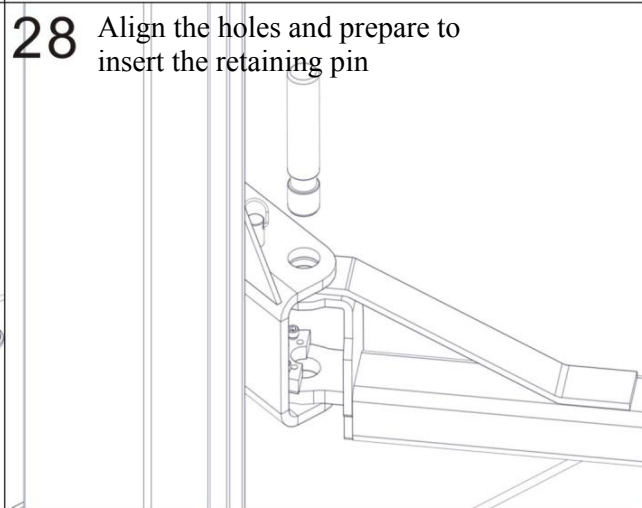
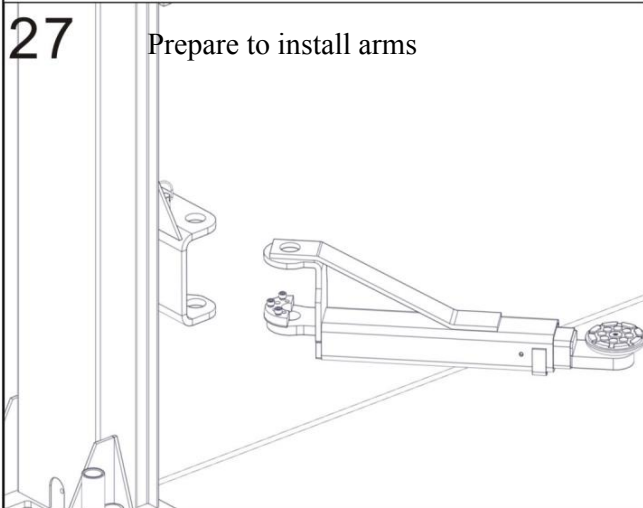

KT-M120

KT-M120

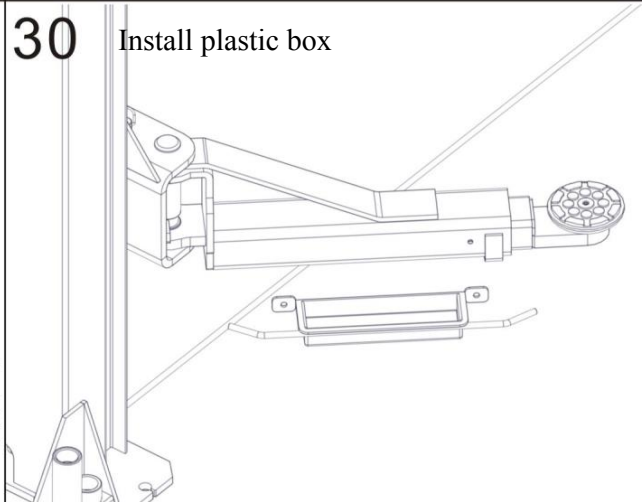
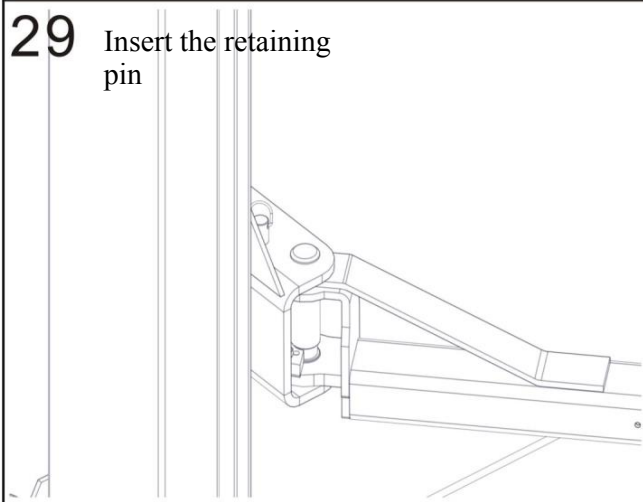

KT-M120

KT-M120

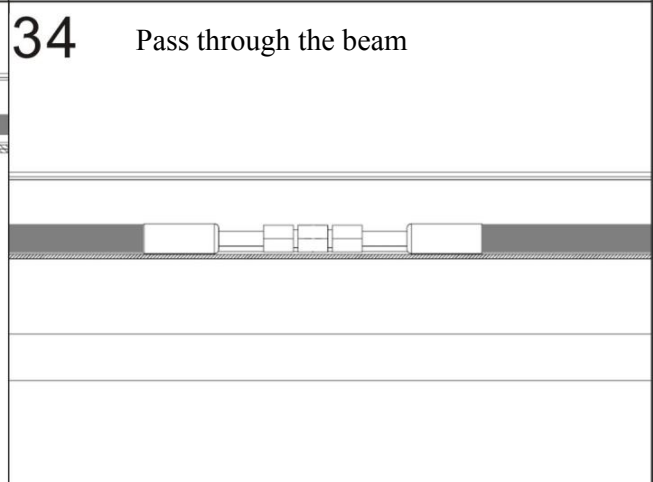
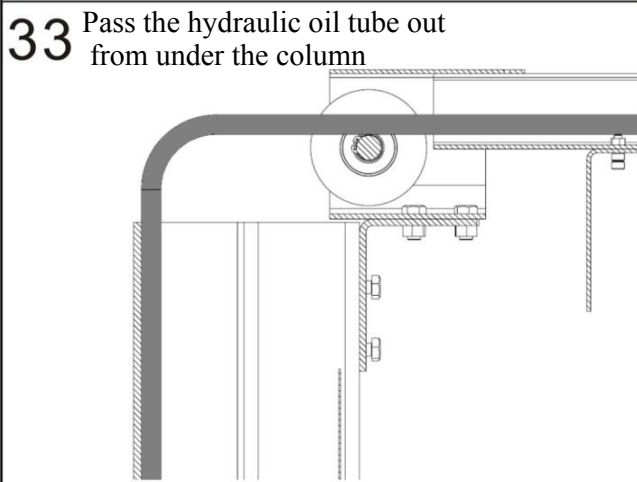
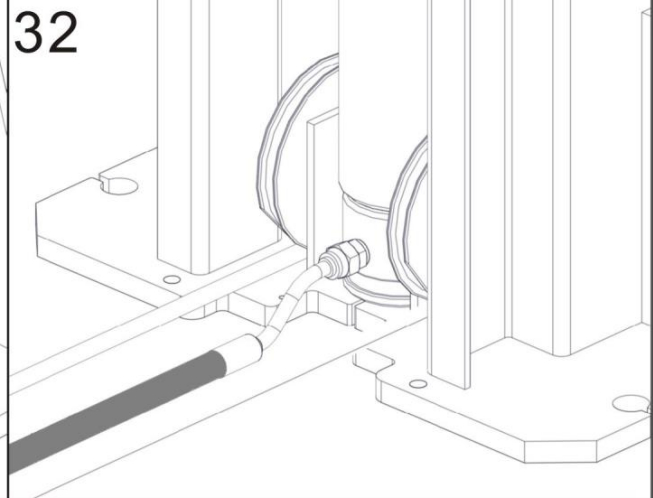
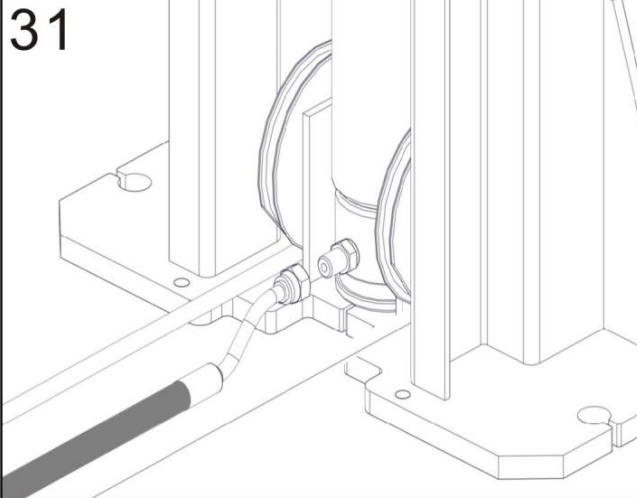

KT-M120

KT-M120

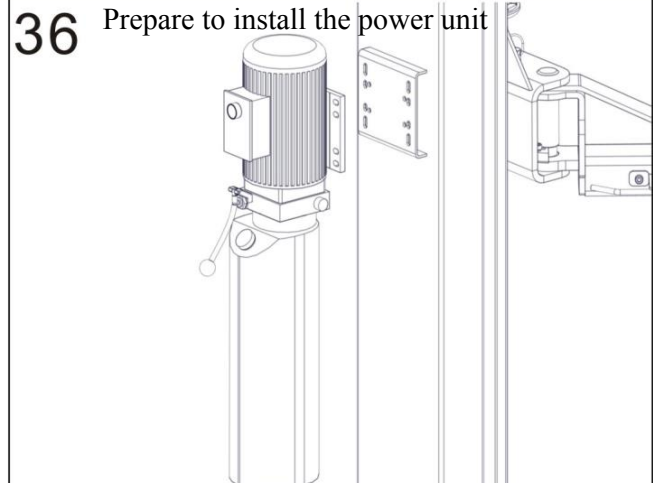
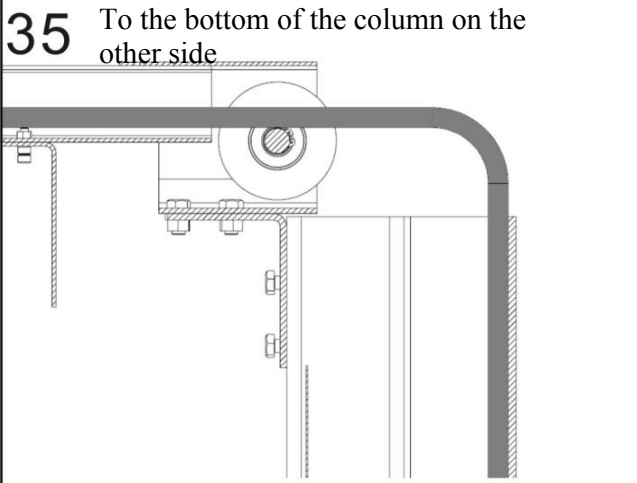

KT-M120

KT-M120

37

Tighten the nut to secure

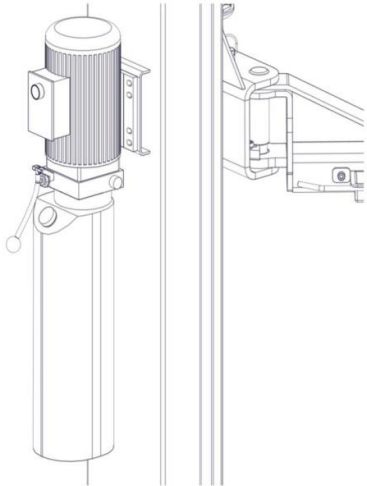

38

Connect the hydraulic tube on this side

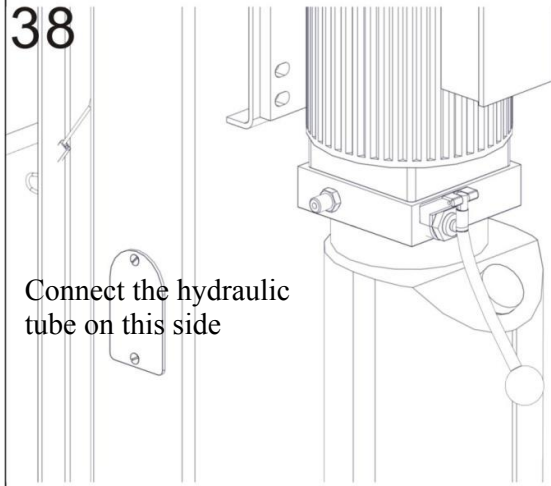

KT-M120

KT-M120

39

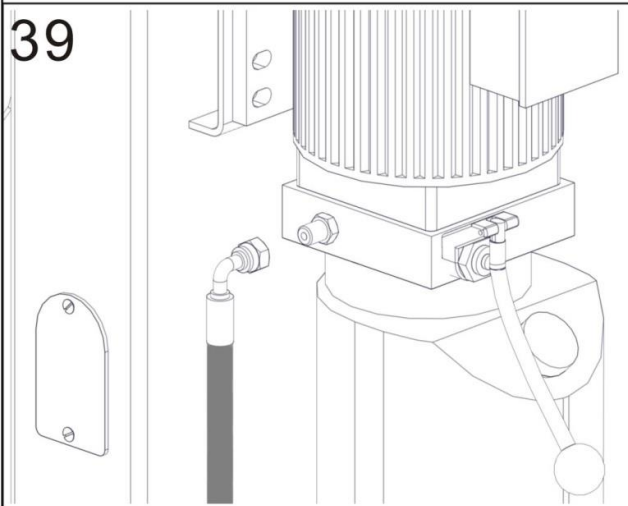

40

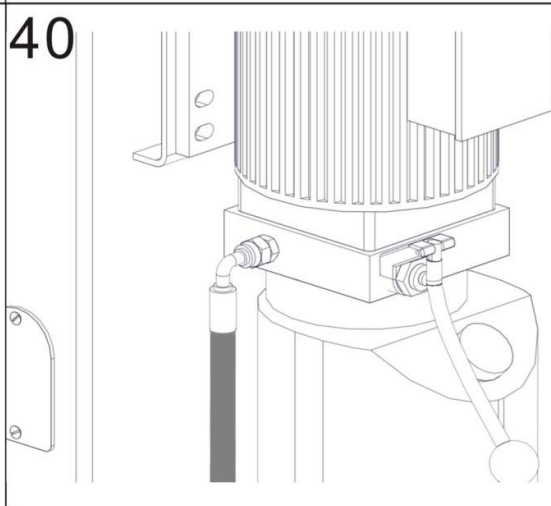

41

Connect the hydraulic tube to the power unit

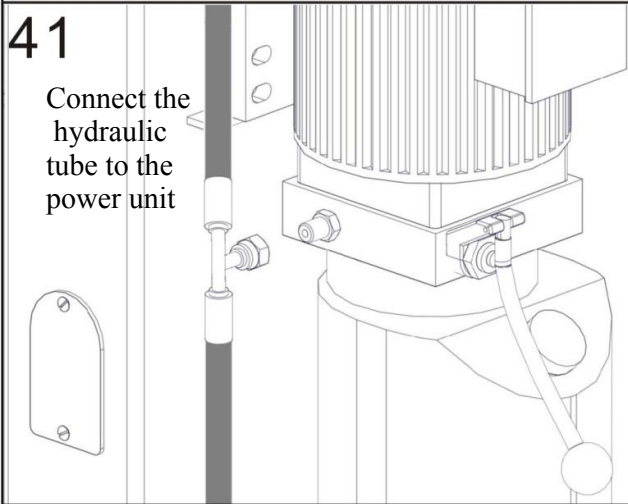

42

Connect the hydraulic tube to the power unit

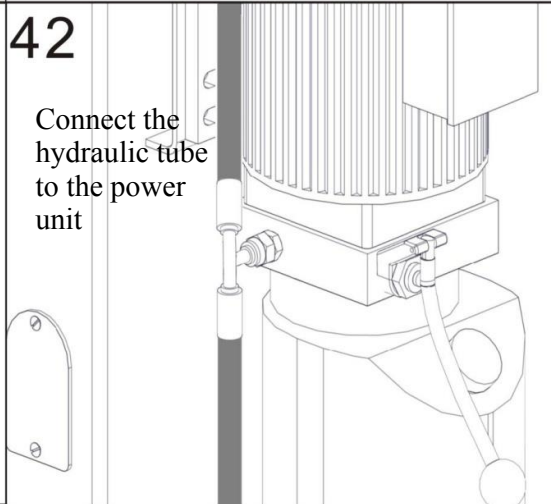

KT-M120

KT-M120

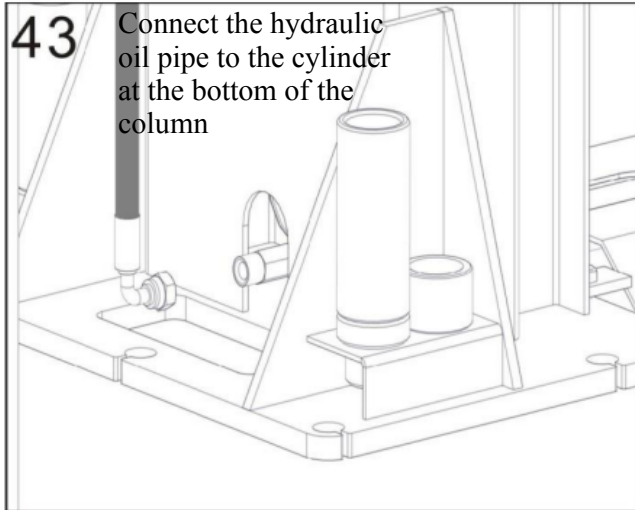

KT-M120

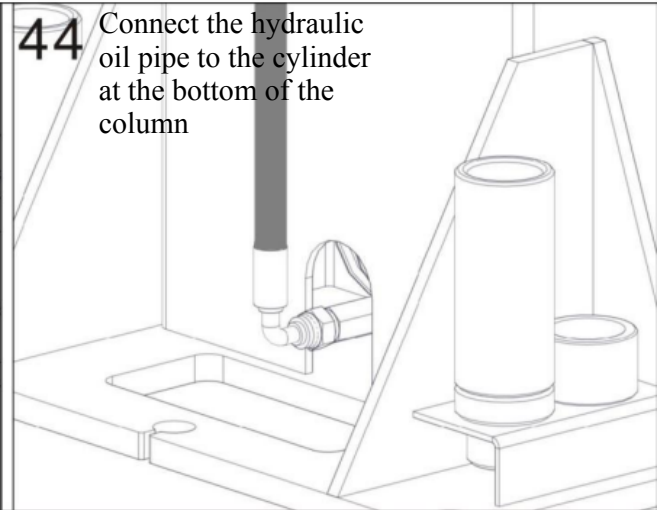

KT-M120

There is a detailed installation video on our youtube channel: @katool1251

Shutoff bar installation





If your lift is **not** functioning correctly, you must take it out of service until it is fixed. All repair work must be performed by qualified personnel. If your organization has Lockout/Tagout policies, implement them after connecting the Lift to the power source.

LIFT WILL NOT RAISE

POSSIBLE CAUSE

1. Air in oil, (1,2,8,13)
2. Cylinder binding, (9)
3. Cylinder leaks internally, (9)
4. Motor run backward under pressure, (11)
5. Lowering valve leaks, (3,4,6,10,11)
6. Motor runs backwards, (7,14,11)
7. Pump damaged, (10,11)
8. Pump won't prime, (1,8,13,14,3,12,10,11)
9. Relief valve leaks, (10,11)
10. Voltage to motor incorrect, (7,14,11)

REMEDY

INSTRUCTION

- | | |
|--|--|
| 1. Check for proper oil level..... | The oil level should be up to the bleed screw in the reservoir with the lift all the way down. |
| 2. Bleed cylinders..... | See Installation Manual |
| 3. Flush- Release valve to get rid of.....
possible contamination | Hold release handle down and start unit allowing it to run for 15 seconds. |
| 4. Dirty oil..... | Replace oil with clean Dexron ATF. |
| 5. Tighten all fasteners..... | Tighten fasteners to recommended torques. |
| 6. Check for free movement of release..... | If handle does not move freely, replace bracket or handle assembly. |
| 7. Check motor is wired correctly. | Compare wiring of motor to electrical diagram on drawing. |
| 8. Oil seal damaged or cocked..... | Replace oil seal around pump shaft. |
| 9. See Installation Manual..... | Consult Lift Manufacturer. |
| 10. Replace with new part..... | Replace with new part. |
| 11. Return unit for repair..... | Return unit for repair. |
| 12. Check pump-mounting bolts..... | Bolts should be 15 to 18 ft. lbs. |
| 13. Inlet screen clogged..... | Clean inlet screen or replace. |
| 14. Check wall outlet voltages and wiring..... | Make sure unit and wall outlet are wired properly. |

MOTOR WILL NOT RUN

POSSIBLE CAUSE

1. Fuse blown, (5,2,1,3,4)
2. Limit switch burned out, (1,2,3,4)
3. Microswitch burned out, (1,2,3,4)
4. Motor burned out, (1,2,3,4,6)
5. Voltage to motor incorrect, (2,1,7)

REMEDY

1. Check for correct voltage.....
2. Check motor is wired correctly.....
3. Don't use extension cords.....
4. Replace with new part.....
5. Reset circuit breaker/fuse.....
6. Return unit for repair.....
7. Check wall outlet voltage and wiring.....

INSTRUCTIONS

- Compare supply voltage with voltage on motor name tag. Check that the wire is sized correctly. N.E.C table 310-12 requires AWG 10 for 25 amps.
- Compare wiring of motor to electrical diagram on drawing.
- According to NEC: The size of the conductors should be such that the voltage drop would not exceed 3% to the farthest outlet for power. *Do not run motor at 115 VAC - damage to the motor will occur.
- Replace with new part.
- Reset circuit breaker/fuse.
- Return unit for repair.
- Make sure unit and wall outlet is wired properly. Motor must run at 208/230 VAC.

LIFT LOWERS SLOWLY OR NOT AT ALL

POSSIBLE CAUSE

1. Cylinders binding, (1)
2. Release valve clogged, (5,4,2,3)
3. Pressure fitting too long, (6)

REMEDY

1. See Installation Manual.....
2. Replace with new part.....
3. Return for repair.....
4. Check oil.....
5. Clean release valve.....
6. Replace fitting with short thread lead.....

INSTRUCTIONS

- Consult Lift Manufacturer.
- Replace with new part.
- Return for repair.
- Use clean 10-WT hydraulic oil or Dexron automatic transmission fluid only. If ATF is contaminated, replace with clean ATF and clean entire hydraulic system.
- Wash release valve in solvent and blow out with air.
- Replace fitting with short thread lead.

WILL NOT RAISE LOADED LIFT

POSSIBLE CAUSE

1. Air in oil, (1,2,3,4)
2. Cylinder binding, (5)
3. Cylinder leaks internally, (5)
4. Lift overloaded, (6,5)
5. Lowering valve leaks, (7,8,1,5,9)
6. Motor runs backwards, (10,12,9)
7. Pump damaged, (5,9)
8. Pump won't prime, (1,2,3,4,5,11,9)
9. Relief valve leaks, (8,5,9)
10. Voltage to motor incorrect, (10,12,5)

REMEDY

- | | |
|---|--|
| 1. Check oil level..... | The oil level should be up to the bleed screw in the reservoir with the lift all the way down. |
| 2. Check/Tighten inlet tubes..... | Replace inlet hose assembly. |
| 3. Oil seal damaged or cocked..... | Replace oil seal and install. |
| 4. Bleed cylinders..... | See Installation Manual. |
| 5. See Installation Manual..... | Consult Lift Manufacturer. |
| 6. Check vehicle weight..... | Compare weight of vehicle to weight limit of the lift. |
| 7. Flush release valve..... | Hold release handle down and start unit allowing it to run for 15 seconds. |
| 8. Replace with new part..... | Replace with new part. |
| 9. Return unit for repair..... | Return unit for repair. |
| 10. Check motor is wired correctly..... | Compare wiring of motor to electrical diagram on power unit drawing. |
| 11. Inlet screen clogged..... | Clean inlet screen or replace. |
| 12. Check wall outlet voltage and wiring..... | Make sure unit and wall outlet is wired properly. |

INSTRUCTIONS

IMPORTANT

If a vehicle becomes stranded in the air, follow all operation instructions as shown on pages 33 - 38.

If, after observing that all mechanical locks are released and the lift still fails to move following all standard operating procedures, immediately stop using the lift and contact the factory or a factory-approved service center for further instructions.

LIFT WILL NOT STAY UP

POSSIBLE CAUSE

1. Air in oil, (1, 2, 3)
2. Check valve leaks, (6)
3. Cylinders leak internally, (7)
4. Lowering valve leaks, (4, 5, 1, 7, 6)
5. Leaking fittings, (8)

REMEDY

1. Check oil level..... The oil level should be up to the bleed screw in the reservoir with the lift all the way down.
2. Oil seal damaged and cocked..... Replace oil seal around pump shaft.
3. Bleed cylinder..... Refer to Installation Manual.
4. Flush release valve..... Hold release handle down and start unit allowing it to run for 15 seconds.
5. Replace with new valve..... Replace with new valve.
6. Return unit for repair..... Return unit for repair.
7. See Installation Manual..... Consult Lift Manufacturer.
8. Check complete hydraulic system for leaks..... Tighten all hydraulics fittings and inspect all hoses.

INSTRUCTIONS

